

# OUTDOORCHEF – Collection 2013

Händlerdokumentation





## OUTDOORCHEF Deutschland - Ihr Team:



**Peter Kovacs**  
Vertriebsdirektor  
Deutschland  
Österreich

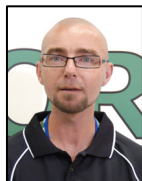

**Alex Bächlin**  
GVL Süd-West  
PLZ 70-73, 75-79  
[alex.baechlin@dkbrands.de](mailto:alex.baechlin@dkbrands.de)  
Mobil 0173 7222396



**Sven Wittig**  
GVL Nord  
PLZ 2, 30-32, 38-39, 49  
[sven.wittig@dkbrands.de](mailto:sven.wittig@dkbrands.de)  
Mobil 0176 23299489



**Jochen Ohgke**  
GVL Mitte-West  
PLZ 33,34,37,4-48,5-53,57-59  
[jochen.ohgke@dkbrands.de](mailto:jochen.ohgke@dkbrands.de)  
Mobil 0170 9658961

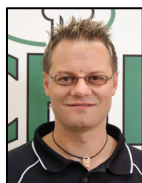

**Pasquale Greco**  
GVL Süd-Ost  
PLZ 80-89, 90-94  
[pasquale.greco@dkbrands.de](mailto:pasquale.greco@dkbrands.de)  
Mobil 0160 97085522



**Ralf Bernhard**  
GVL Mitte-Ost  
PLZ 0,35,36,54-56,6,74,97-99  
[ralf.bernhard@dkbrands.de](mailto:ralf.bernhard@dkbrands.de)  
Mobil 0151 46762049

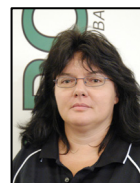

**Barbara Griebing**  
Verkauf Innendienst  
Administration  
[info@outdoorchef.de](mailto:info@outdoorchef.de)  
07623 74190-0



**Sascha Kunimünc**  
Verkauf Innendienst  
IT, Administration, Key Account  
[info@outdoorchef.de](mailto:info@outdoorchef.de)  
07623 74190-15



**Katja Nowak**  
Verkauf Innendienst  
Promotionen/Events  
[grillevents@outdoorchef.de](mailto:grillevents@outdoorchef.de)  
07623 74190-13



**Manuel Kienle**  
Verkauf Innendienst  
After Sales Service  
[service@outdoorchef.de](mailto:service@outdoorchef.de)  
07623 74190-14

## OUTDOORCHEF Austria - Ihr Team:



**Wolfgang Kain**  
Gebietsverkaufsleiter  
Nord/West  
[wolfgang.kain@dkbrands.com](mailto:wolfgang.kain@dkbrands.com)  
0664 1430676



**Walter Schenk**  
Gebietsverkaufsleiter  
Süd/Ost  
[walter.schenk@dkbrands.com](mailto:walter.schenk@dkbrands.com)  
0664 1430676



**Helmut Hengst**  
Verkauf Außendienst  
[helmut.hengst@outdoorchef.at](mailto:helmut.hengst@outdoorchef.at)  
0664 88611333



**Gabi Hänseler**  
Vertriebsinnendienst  
[info@outdoorchef.at](mailto:info@outdoorchef.at)  
+49 7623 74190-16

## Das OUTDOORCHEF Grill- und Zubehörsortiment

### *Base-Line*



### *Classic-Line*



### *Cubic-Line*



### *Australian-Line*



### *Elektro Kugelgrill*



### *Charcoal-Line*



### *Systemzubehör*



### *Universalzubehör*



## Die Trichtertechnologie beim Gaskugelgrill

### Normalposition

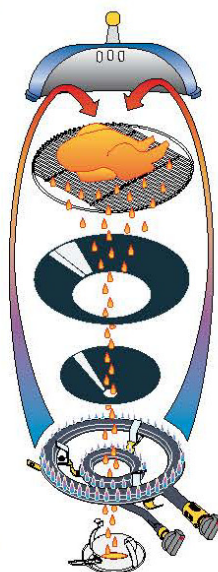

#### Grillen – Garen – Backen (Normalposition)

Für indirektes Grillen, zum Garen und Backen wird der obere Trichter mit der grossen Öffnung nach oben in den Kugelgrill eingesetzt. Die Hitze des Gasbrenners steigt an den Innenseiten der Grillkugel hoch und verteilt sich gleichmässig in der ganzen Kugel.

Der kleine Trichter unten wird mit der grossen Öffnung nach oben eingesetzt. Er schützt den Brenner vor herabtropfender Flüssigkeit und leitet diese in die Auffangschale unterhalb des Grills.

### Vulkanposition

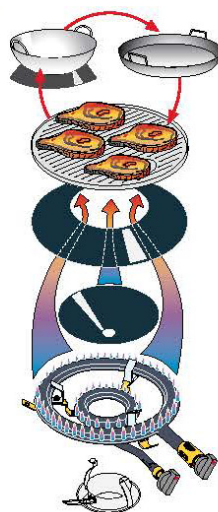
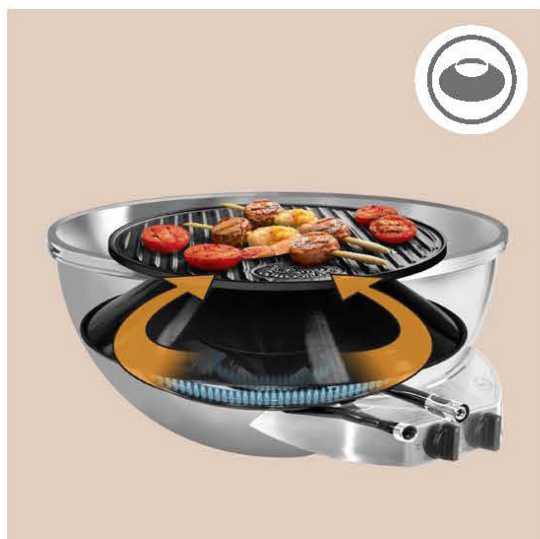

#### Kochen – Braten (Vulkanposition)

Für Grillen bei sehr hoher Temperatur oder mit einer Gusseisenplatte wird der obere Trichter umgekehrt in die Grillkugel eingesetzt. So entsteht gezielt eine sehr grosse Hitze in der Mitte des Grillrostes oder auf das Systemzubehör wie Gusseisenplatte, Wok, Universalpfanne etc.



## Die Vorteile beim Gaskugelgrill



Der drehbare Trichter für gesundes und vielseitiges Grillen.



Alle gastechnischen Teile sind vormontiert.



Kugel, Grillrost, kleiner und grosser Trichter sowie grosser Ringbrenner sind emailliert und deshalb einfach zu reinigen.



Elektrische Mehrfachzündung, inklusive Batterie.



Robuste und gut manövrierbare Fahrgestelle.



Alle Grills sind mit einem Thermometer, Besteckhalter und einer zweiteiligen Fettauffangschale ausgestattet.

## Base-Line



**NEW**



**Porto**

**City Tripod**



	<b>City Tripod vanilla</b> 18.127.78	<b>City Tripod schwarz</b> 18.127.45	<b>Porto schwarz</b> 18.127.28
EAN-Code			
Farbe Kugel / Gestell	vanilla / schwarz	schwarz / schwarz	schwarz / titansilber
Material	Stahl	Stahl	Stahl
Kugel	porzellanemailliert	porzellanemailliert	porzellanemailliert
Fahrgestell	pulverbeschichtet	pulverbeschichtet	pulverbeschichtet
Grillfläche	Ø 39.5 cm	Ø 39.5 cm	Ø 45 cm
Arbeitshöhe	75 cm	75 cm	83 / 43 cm
Brenner	Einzel-Ringbrenner	Einzel-Ringbrenner	Einzel-Ringbrenner
Leistung	4,3 kW	4,3 kW	5,4 kW
Gasverbrauch (max.)	315 g/h	315 g/h	389 g/h
Deckelhalterung	Deckelhaken	Deckelhaken	Deckelhaken
Platzbedarf	44 x 50 cm	44 x 50 cm	65 x 65 cm
Gewicht	15 kg	15 kg	19 kg
<b>UVP</b>	<b>€ 179,00</b>	<b>€ 169,00</b>	<b>€ 279,00</b>

Preis- und Modelländerungen vorbehalten



## Base-Line



**Delta**



**Leon**



	<b>Delta</b> 18.126.58	<b>Leon schwarz</b> 18.127.21	<b>Leon vanilla</b> 18.127.19
EAN-Code	7 611984 007256	7 611984 009083	7 611984 009069
Farbe Kugel Fahrgestell	onyx metallic titansilber	schwarz titansilber	vanille graphite
Material Kugel Fahrgestell Frontablage / Bodenrost	Stahl porzellanemailliert pulverbeschichtet - / Stahl	Stahl porzellanemailliert pulverbeschichtet Metall	Stahl porzellanemailliert pulverbeschichtet Metall
Grillfläche	Ø 45 cm	Ø 54 cm	Ø 54 cm
Arbeitshöhe	83 cm	87 cm	87 cm
Brenner	Einzel-Ringbrenner	Einzel-Ringbrenner	Einzel-Ringbrenner
Leistung	5,4 kW	8,5 kW	8,5 kW
Gasverbrauch (max.)	389 g/h	612 g/h	612 g/h
Deckelhalterung	Deckelhaken	Deckelscharnier	Deckelscharnier
Platzbedarf	60 x 70 cm	80 x 65 cm	80 x 65 cm
Gewicht	20 kg	30 kg	30 kg
<b>UVP</b>	<b>€ 329,00</b>	<b>€ 429,00</b>	<b>€ 429,00</b>

## Classic-Line



	<b>Ambri schwarz</b> 18.127.01	<b>Ambri ruby</b> 18.127.22
EAN-Code	 7 611984 008185	 7 611984 009212
Farbe Kugel Fahrgestell	schwarz titansilber	ruby titansilber
Material Kugel Fahrgestell	Stahl porzellanemailliert pulverbeschichtet Eukalyptusholz (FSC)	Stahl porzellanemailliert pulverbeschichtet Eukalyptusholz (FSC)
Grillfläche	Ø 45 cm	Ø 45 cm
Arbeitshöhe	82 cm	82 cm
Brenner	Einzel-Ringbrenner	Einzel-Ringbrenner
Leistung	5,4 kW	5,4 kW
Gasverbrauch	389 g/h	389 g/h
Deckelhalterung	Deckelscharnier	Deckelscharnier
Platzbedarf	80 x 60 cm	80 x 60 cm
Gewicht	24 kg	24 kg
<b>UVP</b>	<b>€ 399,00</b>	<b>€ 429,00</b>



## Classic-Line



	<b>Ascona blau</b> 18.127.42	<b>Ascona schwarz</b> 18.127.11	<b>Ascona ruby</b> 18.127.24
EAN-Code	 7 611984 009953	 7 611984 008475	 7 611984 009236
Farbe Kugel Fahrgestell	blau titansilber	schwarz titansilber	ruby titansilber
Material Kugel Fahrgestell Frontablage / Bodenrost	Stahl porzellanemailliert pulverbeschichtet Eukalyptusholz (FSC)	Stahl porzellanemailliert pulverbeschichtet Eukalyptusholz (FSC)	Stahl porzellanemailliert pulverbeschichtet Eukalyptusholz (FSC)
Grillfläche	Ø 54 cm	Ø 54 cm	Ø 54 cm
Arbeitshöhe	86 cm	86 cm	86 cm
Brenner	Doppel-Ringbrenner	Doppel-Ringbrenner	Doppel-Ringbrenner
Leistung	1,2 / 8,5 kW	1,2 / 8,5 kW	1,2 / 8,5 kW
Gasverbrauch (max.)	90 / 612 g/h	90 / 612 g/h	90 / 612 g/h
Deckelhalterung	Deckelscharnier	Deckelscharnier	Deckelscharnier
Platzbedarf	100 x 65 cm	100 x 65 cm	100 x 65 cm
Gewicht	32 kg	32 kg	32 kg
<b>UVP</b>	<b>€ 549,00</b>	<b>€ 549,00</b>	<b>€ 579,00</b>

## Classic-Line



	<b>Montreux</b> 18.127.09
EAN-Code	 7 611984 008451
Farbe Kugel Fahrgestell	schwarz titansilber
Material Kugel Fahrgestell Seitenablage Bodenrost	Stahl porzellanemailliert pulverbeschichtet Granit wetterfester ATC-Verbundstoff
Grillfläche	Ø 54 cm
Arbeitshöhe	84 cm
Brenner	Doppel-Ringbrenner
Leistung	1,2 / 8,5 kW
Gasverbrauch (max.)	90 / 612 g/h
Deckelhalterung	Deckelscharnier
Platzbedarf	118 x 70 cm
Gewicht	40 kg
<b>UVP</b>	<b>€ 699,00</b>



## Classic-Line

**NEW**



	<b>Geneva</b> 18.127.37
EAN-Code	 7 611984 010379
Farbe Kugel Fahrgestell	schwarz Edelstahl
Material Kugel Fahrgestell Seitenablage	Stahl porzellanemailliert Edelstahl pulverbeschichtetes Metall
Grillfläche	Ø 54 cm
Arbeitshöhe	84 cm
Brenner	Doppel-Ringbrenner
Leistung	1,2 / 8,5 kW
Gasverbrauch (max.)	90 / 612 g/h
Deckelhalterung	Deckelscharnier
Platzbedarf	65 x 80 cm
Gewicht	58 kg
<b>UVP</b>	<b>€ 799,00</b>

## Cubic-Line



**Munich**



**Paris DeLuxe**



	<b>Munich</b> 18.127.26	<b>Paris Deluxe</b> 18.127.15
EAN-Code	 7 611984 009274	 7 611984 008925
Farbe Kugel Fahrgestell	onyx metallic titansilber	onyx metallic titansilber
Material Kugel Fahrgestell Arbeitsfläche Bodenrost	Stahl porzellanemailliert pulverbeschichtet Granit Metall	Stahl porzellanemailliert pulverbeschichtet Granit Metall
Grillfläche	Ø 45 cm	Ø 54 cm
Arbeitshöhe	88 cm	88 cm
Brenner	Einzel-Ringbrenner	Doppel-Ringbrenner Seitenbrenner
Leistung	5,4 kW	1,2 / 8,5 kW / 3,8 kW
Gasverbrauch (max.)	389 g/h	90 / 612 / 276 g/h
Deckelhalterung	Deckelscharnier	Deckelscharnier
Platzbedarf	84x60 cm	104 x 73 cm
Gewicht	35 Kg	52 Kg
<b>UVP</b>	<b>€ 549,00</b>	<b>€ 899,00</b>



## Cubic-Line



Integrierter «Steakhouse-Grill» mit Granitabdeckung



Schublade mit Softeinzug



		<b>Venezia</b> 18.127.31
EAN-Code		 7 611984 009304
Farbe Kugel Fahrgestell		onyx titansilber
Material Kugel Fahrgestell Arbeitsflächen Bodenrost		Stahl porzellanemailliert pulverbeschichtet Granit Metall
Grillfläche	Kugel «Steakhouse-Grill»	Ø 54 cm 44,5x35 cm / 1550 cm <sup>2</sup>
Arbeitshöhe		88 cm
Brenner	Kugel «Steakhouse-Grill»	Doppel-Ringbrenner 2-fach Guseisenbrenner
Leistung	Kugel «Steakhouse-Grill»	1,2 / 8,5 kW 2x 3,2 kW = 6,4 kW
Gasverbrauch	Kugel (max.) «Steakhouse-Grill»(max.)	Ca. 90 / 612 g/h ca. 466g/h
Deckelhalterung		Deckelscharnier
Platzbedarf		144 x 73 cm
Gewicht		68 kg
<b>UVP</b>		<b>€ 1149,00</b>

## Die Vorteile bei der Australian Line

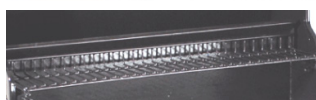

- Gussroste und Gussplatten (Canberra, Perth, Auckland) emailliert
- Grillroste (Cairns/Hamilton) porzellanemailliert
- langlebig und einfach zu reinigen.
  
- porzellanemaillierter Warmhalterost für zusätzliche Grillfläche (nicht bei Cairns/Hamilton)
  
- porzellanemaillierte Flammenschutzbleche – langlebig und einfach zu reinigen
  
- einfach zu bedienende, elektrische Mehrfachzündung (inklusive Batterie) für Zündkomfort und Sicherheit
  
- Unterschrank mit großzügigem Stauraum aus pulverbeschichtetem Stahl bietet Platz für Grillzubehör und für 5kg Gasflaschen
  
- robuste und gut manövrierbare Fahrgestelle erleichtern Umstellen der Geräte.
  
- alle Grills mit Thermometer zur einfachen Temperatursteuerung ausgestattet.
  
- designorientierte Kantenabdeckungen aus Edelstahl; zudem Schutz des emaillierten Deckels.

## Australian-Line



	<b>Cairns</b> 18.131.13	<b>Hamilton</b> 18.131.15
EAN-Code		
Farbe Backhaube Fahrgestell Unterschrank	schwarz schwarz schwarz	schwarz schwarz schwarz
Material Backhaube Fahrgestell Unterschrank	Stahl porzellanemailliert pulverbeschichtet pulverbeschichtet	Stahl porzellanemailliert pulverbeschichtet pulverbeschichtet
Grillfläche	46.5 x 44,5 cm / 2070cm <sup>2</sup> 2 x Grillrost emailliert	46.5 x 43 cm / 2070cm <sup>2</sup> 2 x Grillrost emailliert
Arbeitshöhe	85 cm	85 cm
Arbeitsflächen	klappbare Seitenablagen aus Metall	klappbare Seitenablagen aus Metall
Brenner	3 x Gusseisenbrenner	3 x Gusseisenbrenner 1 x Seitenbrenner
Leistung	3 x 2,5 kW = 7,5 kW	3 x 2,5 kW = 7,5 kW 1 x 3,8 kW
Gasverbrauch ges. (max.)	546 g/h	822 g/h
Platzbedarf	121x56cm / 76x56cm	121x56cm / 76x56cm
Gewicht	30 Kg	32 Kg
<b>UVP</b>	<b>€ 399,00</b>	<b>€ 449,00</b>



## Australian-Line



Klappbare Seitenablage

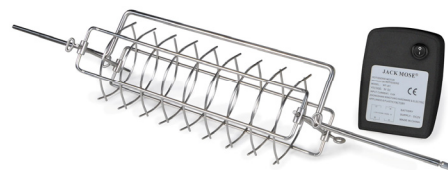

zusätzlicher Stromanschluß

	<b>Canberra</b> 18.131.17		<b>Edelstahl Bratenkorb-Set zur OUTDOORCHEF Australian Line mit Motor</b>
EAN-Code	 7 611984 009854		14.331.07
Farbe Backhaube Fahrgestell Unterschrank	schwarz schwarz schwarz		 7 611984 010034
Material Backhaube Fahrgestell Unterschrank	Stahl porzellanemailliert pulverbeschichtet pulverbeschichtet		Stablänge 76cm; Auflagefläche ca. 70cm; Korbtiefe verstellbar von 4,5 bis 14cm; Korblänge 37cm
Grillfläche	66 x 44,5 cm / 2825 cm <sup>2</sup> 3 x Grillrost und 1 x Grillplatte		Passend zur OC-Australian Line und zu anderen Grillstationen (auf Maße achten!)
Arbeitshöhe	90 cm		Verstellbarer Drehkorb aus Edelstahl, Motor (Batteriebetrieb 2 x Mono D nicht enthalten, Strombetrieb Adapter nicht enthalten)
Arbeitsflächen	klappbare Seitenablagen aus Metall		passt sich dem Grillgut an; kein Aufspießen; ideal für große Braten, Fisch großes Grillgut
Brenner	4 x Gusseisenbrenner		VE: 6 Stück
Leistung	4x 3,2 kW = 12,8 kW		<b>€ 89,90</b>
Gasverbrauch ges. (max)	932 g/h		
Platzbedarf	139 x 56 cm bzw. 92 x 56 cm		
Gewicht	61 Kg		
<b>UVP</b>	<b>€ 499,00</b>		

## Australian-Line



links Seitenbrenner  
klappbar



	<b>Perth</b> 18.131.19
EAN-Code	 7 611984 009878
Farbe Backhaube Fahrgestell Unterschrank	schwarz schwarz schwarz
Material Backhaube Fahrgestell Unterschrank	Stahl porzellanemailliert pulverbeschichtet pulverbeschichtet
Grillfläche	65 x 44.5 cm / 2825 cm <sup>2</sup> Grillrost und Grillplatte emailliert
Arbeitshöhe	90 cm
Arbeitsflächen	klappbare Seitenablagen aus Metall
Brenner	4 Gusseisenbrenner 1 Seitenbrenner
Leistung	4 x 3,2 kW = 12,8 kW 1 x 3,8 kW
Gasverbrauch ges. (max.)	ca. 1200g/h
Platzbedarf	139 x 56 cm bzw. 92 x 56 cm
Gewicht	61 kg
<b>UVP</b>	<b>€ 599,00</b>

## Australian-Line



Infrarotbrenner für extrem hohe Temperaturen



links Seitenbrenner mit Abdeckung aus Granit



rechts Seitenablage aus Granit mit seitlichem Papierrollenhalter



	<b>Auckland</b> 18.131.23
EAN-Code	 7 611984 009915
Farbe Backhaube Fahrgestell Unterschrank	Chromnickelstahl Chromnickelstahl Schwarz
Material Backhaube doppelwandig Fahrgestell / Bediendisplay Unterschrank	Stahl/Edelstahl Außenseite Edelstahl 304 Edelstahl pulverbeschichtet
Grillfläche	65 x 44.5 cm / 2825 cm <sup>2</sup> Grillrost und Grillplatte
Arbeitshöhe	90 cm
Arbeitsflächen	Seitenablagen Metall mit Granitabdeckung
Brenner	3 Gusseisenbrenner 1 Seitenbrenner mit Granitabdeckung 1 Hochtemperatur-Infrarotbrenner
Leistung: Gusseisenbrenner Seitenbrenner Infrarotbrenner	3 x 3,2 kW = 9.6 kW 1 x 3.8 kW 1 x 6.2 kW Gesamt = ca. 19.6 kW
Gasverbrauch gesamt (max.)	ca. 1426 g/h
Platzbedarf	139 x 56 cm
Gewicht	64 kg
<b>UVP</b>	<b>€ 799,00</b>



## Elektro Kugelgrill

**NEW**



**LED Temperatursteuerung von 80 bis 300°**

**Umlufthitze für perfektes Grillergebnis**

**Energiesparend durch geschlossenes System**

**Austauschbare Alu-Einlagen auf dem Hitzereflektor führen herabtropfende Fette und Marinaden in eine innenliegende Fettauffangschale.**

**Edelstahlring zur Aufnahme des optionalen Zubehörs verhindert das Verkratzen des Grillrostes.**

<b>ETM TESTMAGAZIN · URTEIL</b>	
Outdoorchef City Electro 420	
<b>SEHR GUT</b>	<b>92,2 %</b>
11 Elektro-Grills im Vergleichstest	Heft 06/2010

	<b>City Electro</b> 18.130.07
EAN-Code	7 611984 010287
Farbe Kugel Gestell	schwarz titansilber
Material Kugel Gestell	Stahl Porzellanemailliert Stahl pulverbeschichtet
Grillfläche	Ø 39,5 cm
Arbeitshöhe	75 cm
Grillhöhe	100 cm
Leistung	2,0 kW
Deckelhalterung	Deckelhaken
Platzbedarf	60 x 60 cm
Gewicht	15 kg
<b>UVP</b>	<b>€ 199,00</b>

## Die Trichtertechnologie beim Holzkohle-Kugelgrill

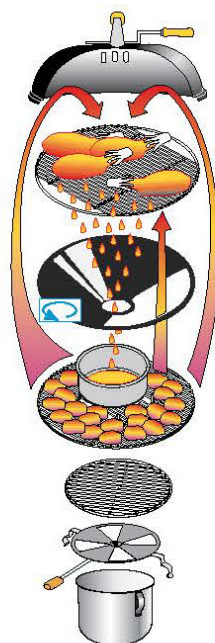
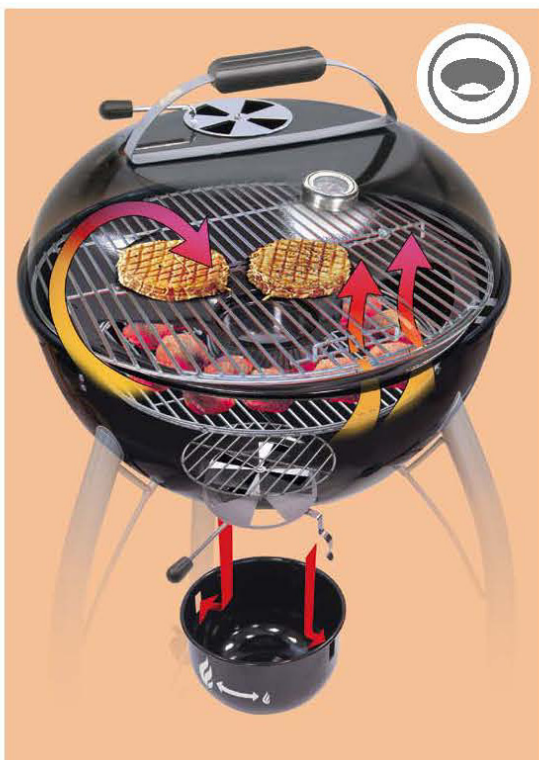

### Direktes Grillen

Zum Anbraten kann das Grillgut direkt über die Glut bzw. den ausgesparten Trichterteil gelegt werden. Besonders geeignet ist diese Methode auch für Kurzgebratenes.

### Indirektes Grillen

Zum Garen, Dünsten oder Backen eignet sich die indirekte Methode. Hier wird das Grillgut über dem geschlossenen Teil des Trichters ausgelegt und vor der direkten Flamme geschützt. Das Grillgut gart durch die erhitzte Luft. Diese Methode eignet sich für grosse Fleischstücke, die langsam gegart werden oder zum Backen.

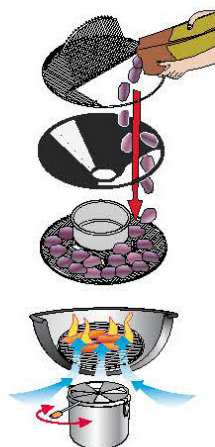

Der aufklappbare Grillrost erleichtert das Ein- und Nachfüllen der Holzkohle- Briketts.

Der kleine Grillrost ermöglicht das Anzünden der Kohle direkt im Grill (Kaminwirkung).

Die Hitze kann durch das Öffnen und Schliessen der Lüftungsöffnungen problemlos reguliert werden.

## Die Vorteile bei der Charcoal-Line



Mit der patentierten Trichtertechnologie für direktes und indirektes Grillen.



Der aufklappbare Grillrost erleichtert das Ein- und Nachfüllen der Holzkohle-Briketts während des Grillens.



Überflüssiger Fleischsaft wird in einer emaillierten Wasserschale aufgefangen. Die Flüssigkeit, die während des Grillvorganges verdampft, verhindert das Austrocknen des Grillgutes.



Die Hitze kann durch das Öffnen und Schliessen der Lüftungsöffnungen problemlos reguliert werden.



Fahrgestelle mit einer angenehmen und arbeitsgerechten Grillhöhe, robust und gut manövrierbar.



Alle Grills sind mit einem Thermometer, Besteckhalter und geschlossenem Aschebehälter ausgestattet.



## Charcoal-Line

**City Grill**



**CITY CHARCOAL 420**

**NEW**



**EASY CHARCOAL 480**

**NEW**



**EASY CHARCOAL 570**

**NEW**



	<b>City Charcoal 420</b> 18.125.33	<b>Easy Charcoal 480</b> 18.125.34	<b>Easy Charcoal 570</b> 18.125.35
EAN-Code	 7 611984 010218	 7 611984 010225	 7 611984 010232
Farbe Kugel Gestell	Schwarz Schwarz	schwarz titansilber	schwarz titansilber
Material Kugel Fahrgestell	Stahl porzellanemailliert pulverbeschichtet	Stahl porzellanemailliert pulverbeschichtet	Stahl porzellanemailliert pulverbeschichtet
Grillfläche	Ø 39.5 cm	Ø 45 cm	Ø 54 cm
Arbeitshöhe	75/47 cm	80 cm	83 cm
Deckelhalterung	Deckelhaken	Deckelhaken	Deckelhalter
Platzbedarf	44 x 50 cm	60 x 60 cm	80 x 60 cm
Gewicht	8.5 kg	18 kg	25 kg
<b>UVP</b>	<b>€ 99,00</b>	<b>€ 149,00</b>	<b>€ 229,00</b>

## Charcoal-Line

**NEW**



**ROVER 480**

**NEW**



**ROVER 570LH**

**NEW**



**CLASSIC CHARCOAL 570**



	<b>Rover 480</b> 18.125.36	<b>Rover 570LH</b> 18.125.37	<b>Classic Charcoal 570</b> 18.125.38
EAN-Code	 7 611984 010249	 7 611984 010256	 7 611984 010263
Farbe Kugel Fahrgestell	schwarz titansilber	schwarz titansilber	schwarz titansilber
Material Kugel Fahrgestell Ablagen	Stahl porzellanemailliert pulverbeschichtet	Stahl porzellanemailliert pulverbeschichtet	Stahl porzellanemailliert pulverbeschichtet Eukalyptusholz (FSC)
Grillfläche	Ø 45 cm	Ø 54 cm	Ø 54 cm
Arbeitshöhe	80 cm	84 cm	86 cm
Deckelhalterung	Deckelscharnier	Deckelscharnier	Deckelscharnier
Platzbedarf	65 x 65 cm	75 x 65 cm	65 x 100 cm
Gewicht	18 kg	25 kg	34 kg
<b>UVP</b>	<b>€ 179,00</b>	<b>€ 269,00</b>	<b>€ 369,00</b>

## Systemzubehör



**Gourmet Set**  
(Universalpanne Ø 39 cm,  
Pizzablech Ø 40 cm)



**Pizza- und Backblech**  
Ø 40 cm



**Universalpanne**  
Ø 46 cm

**NEW**



**Pizza- und Brotbackstein**  
Ø 41 cm (inkl. Schaufel)



**Back- und Kuchenblech**  
Ø 30 cm



**Grillrost klein**  
Ø 34 cm

	<b>Gourmet-Set</b> 18.211.29	<b>Pizza- und Backblech</b> 18.211.27	<b>Universalpanne</b> 18.211.22	<b>Pizza- und Brotbackstein</b> 18.211.61	<b>Back- und Kuchenblech</b> 18.211.41	<b>Grillrost klein</b> 18.211.06
EAN-Code						
Masse	Blech Ø40 cm Panne Ø39 cm	Ø 40 cm	Ø 46 cm	Ø 41cm	Ø 30cm	Ø 34cm
für Kugelgröße	480er / 570er	480er / 570er	570er	480er / 570er	420er – 570er	480er / 570er
Material	Metall	Metall	Metall	Cordierit	Metall	Stahl
Veredelung	emailliert	Emailliert	emailliert		Antihaft	Emailliert
Merkmale	2-teilig			inkl. Schaufel		Ideal für Hähnchen/Truthahn
Bestelleinheit	6 Stück	6 Stück	6 Stück	3 Stück	6 Stück	6 Stück
<b>UVP</b>	<b>€ 49,90</b>	<b>€ 22,90</b>	<b>€ 49,90</b>	<b>€ 79,90</b>	<b>€ 22,90</b>	<b>€ 16,90</b>

Alle mit einem gekennzeichneten Zubehör enthalten eine Broschüre mit Rezepten sowie wissenswertes zur Anwendung.



## Systemzubehör



**Gusseisenplatte „Plancha“**  
Ø 39 cm



**Wok aus Gusseisen**  
Ø 35 cm



**Aromapfanne**  
aus Gusseisen Ø 23 cm



**Pfanne aus Gusseisen**  
Ø 38 cm



**Gourmet-Halbmond**  
2-teilig



**Gusseisenplatte**  
44 x 24,5 cm

	<b>Gusseisenplatte „Plancha“</b> 18.211.24	<b>Wok aus Gusseisen</b> 18.211.39	<b>Aromapfanne aus Gusseisen</b> 18.211.50	<b>Pfanne aus Gusseisen</b> 18.211.40	<b>Gourmet-Halbmond</b> 18.211.51	<b>Gusseisenplatte</b> 14.112.40
EAN-Code						
Masse	Ø 39 cm	Ø 35 cm	23 Ø cm	Ø 38 cm		44 x 24,5 cm
für Kugelgröße	480er / 570er	480er / 570er	480er / 570er	480er / 570er	480er / 570er	Australien Line Venezia
Material	Gusseisen matt emailliert	Gusseisen matt emailliert	Gusseisen matt emailliert	Gusseisen matt emailliert	Metall, porzellan-emailliert	Gusseisen matt emailliert
Merkmale	für Kurzgebratenes	mit Aufsatz	zum Aromatisieren von Grilladen		Dünsten, Zubereiten von Fleisch & Gemüse gleichzeitig	für Kurzgebratenes
Bestelleinheit	3 Stück	3 Stück	6 Stück	3 Stück	6 Stück	3 Stück
<b>UVP</b>	<b>€ 59,90</b>	<b>€ 49,90</b>	<b>€ 24,90</b>	<b>€ 59,90</b>	<b>€ 44,90</b>	<b>€ 69,90</b>

Alle mit einem gekennzeichneten Zubehör enthalten eine Broschüre mit Rezepten sowie wissenswertes zur Anwendung.

## Systemzubehör



**Pizzaschaufel**



**«Grillspass Heute»**  
Grill-Kochbuch



**«Culinary Entertainer»**  
Grill-Kochbuch



**Seitenablage**  
für Kugelgrill 480



**Deckelhalter**  
für Kugelgrills 480 und 570



**Seitenablage**  
für Kugelgrill 570

	<b>Pizzaschaufel</b>	<b>Grillspass heute</b>	<b>Culinary Entertainer</b>	<b>Seitenablage 480</b>	<b>Deckelhalter</b>	<b>Seitenablage 570</b>
	14.112.47	14.410.12	14.410.13	18.291.07	18.291.05	18.291.08
EAN-Code						
für Kugelgröße	alle			480er	480er / 570er	570er
Material	Metall, antihafbeschichtet, 40 * 34 cm			Eukalyptusholz (FSC)	Chromstahl	Eukalyptusholz (FSC)
Merkmale	Für alle Pizza- und Brotbacksteine	für Gaskugelgrills	für Gaskugelgrills	Abnehmbar	abnehmbar	abnehmbar
Bestelleinheit	6 Stück	10 Stück	10 Stück	6 Stück	6 Stück	6 Stück
<b>UVP</b>	<b>€ 19,90</b>	<b>€ 11,90</b>	<b>€ 19,90</b>	<b>€ 39,90</b>	<b>€ 14,90</b>	<b>€ 49,90</b>

## Systemzubehör



**Gourmet-Set City Grill**  
(Universalpfanne Ø 34cm,  
Pizzablech Ø 35 cm)



**Gusseisenplatte „Plancha“**  
Ø 33 cm



**Pizza- und Brotbackstein**  
Ø 32 cm

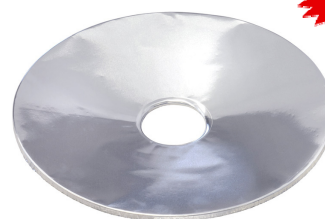

**NEW**

**Alu-Schutzfolie**  
zu Hitzereflektor

	<b>Gourmet-Set City Grill</b> 18.211.32	<b>Gusseisenplatte „Plancha“</b> 18.211.25	<b>Pizza- und Brotbackstein</b> 18.211.54	<b>Alu- Schutzfolie</b> 18.211.74
EAN-Code				
Masse	Blech Ø35 cm Pfanne Ø34 cm	Ø 33 cm	Ø 32 cm	35 cm
für Kugelgröße	420er City Line	420er City Line	420er City Line	City Electro 420
Material	Metall	Gusseisen	Cordierit	Aluminium
Veredelung	Pfanne: emailliert Blech: emailliert	matt emailliert		
Merkmale	2-teilig	für Kurzgebratenes		
Bestelleinheit	6 Stück	3 Stück	3 Stück	6 Stück
<b>UVP</b>	<b>€ 39,90</b>	<b>€ 49,90</b>	<b>€ 59,90</b>	<b>€ 9,90</b>

Alle mit einem gekennzeichneten Zubehör enthalten eine Broschüre mit Rezepten sowie wissenswertes zur Anwendung.



## Systemzubehör

**NEW**



**Unterbau**  
zu City Gas



**Tragetasche**  
zu City Gas

**NEW**



**Abdeckhaube, grau**  
City Line

	<b>Unterbau zu City Gas</b> 18.291.23	<b>Tragetasche für City Gas</b> 18.221.29	<b>Abdeckhaube, grau</b> 18.221.25
EAN-Code			
Masse			95x44x44cm
für Kugelgröße	City Gas 420	City Gas 420	City Gas mit Tripod, City Charcoal
Material	Stahl	Nylon	Vinyl
Veredelung	Pulverbeschichtet		
Merkmale	Zusatzgestell zu City Gas	erleichtert den Transport	Schutzhülle
Bestelleinheit	6 Stück	6 Stück	12 Stück
<b>UVP</b>	<b>€ 34,90</b>	<b>€ 29,90</b>	<b>€ 24,90</b>

## Universalzubehör



**Grillzange «Quick Lock»**



**Gourmet Spatula**



**Grillpinzette**



**Grillbesteck-Set «Royal»**  
3-teilig

	<b>Grillzange «Quick Lock»</b> 14.112.35	<b>Gourmet Spatula</b> 14.112.36	<b>Grillpinzette</b> 14.112.23	<b>Grillbesteck- «Set Royal»</b> 14.112.18
EAN-Code				
Material	Edelstahl Griff: Softgrip	Edelstahl	Edelstahl	Edelstahl
Merkmale	mit Verschluss	Schaufel ideal zum Wenden für Fisch und Gemüse mit Flaschenöffner	für Meeresfrüchte, Crevetten, Würste und Gemüse	Set mit Bratschaufel, Zange und Gabel
Bestelleinheit	6 Stück	6 Stück	6 Stück	6 Stück
<b>UVP</b>	<b>€ 14,90</b>	<b>€ 18,90</b>	<b>€ 19,90</b>	<b>€ 32,90</b>

## Universalzubehör



**Gourmet Check**



**Grill Lederhandschuhe**  
L (Paar)



**Grill Lederhandschuhe**  
M (Paar)



**Grillschürze**  
**OUTDOORCHEF**



**Abdeckhaube**  
für Gasflasche

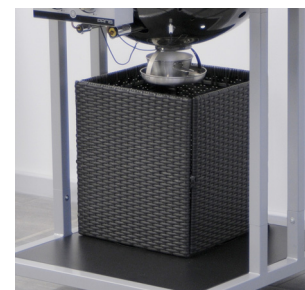

**Abdeckkorb**  
für Gasflaschen aus  
Poly-Rattan

	<b>Gourmet Check</b>	<b>Grill Lederhandschuhe L</b>	<b>Grill Lederhandschuhe M</b>	<b>Grillschürze</b>	<b>Abdeckhaube</b>	<b>Abdeckkorb</b>
	14.491.16	14.491.10	14.491.22	14.112.24	14.212.07	18.221.22
EAN-Code						
Material	Kunststoffgehäuse	Leder	Leder	Baumwolle	Nylon	39x35.5x35.5 cm
Merkmale	Dual-Sensor Thermometer mit Timer Funktion Digital	Paar geschütztes Grillen mit Fingerspitzengefühl	Paar geschütztes Grillen mit Fingerspitzengefühl	Bestickt	Universal-Größe für Gasflaschen von 5-10 kg, mit Klettverschluss	Passend für Paris und Paris DeLuxe , Venezia und Munich
Bestelleinheit	6 Stück	6 Stück	6 Stück	12 Stück	6 Stück	3 Stück
<b>UVP</b>	<b>€ 34,90</b>	<b>€ 19,90</b>	<b>€ 19,90</b>	<b>€ 14,90</b>	<b>€ 14,90</b>	<b>€ 59,90</b>

## Universalzubehör



Grillbürste «Lucy»  
im 24er-Display



Grillbürste «Silvy»

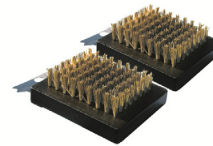

Ersatzkopfset zu  
Grillbürste «Silvy»  
(2 Stück)



Reinigungsbürste «Fredy»



BBQ Cleaner

	<b>Grillbürste «Lucy» 14.421.11</b>	<b>Grillbürste «Silvy» 14.421.12</b>	<b>Ersatzköpfe «Silvy» 14.421.13</b>	<b>Reinigungsbürste «Fredy» 18.211.52</b>	<b>BBQ Cleaner 14.421.16</b>
EAN-Code	 7 611984 004996	 7 611984 005559	 7 611984 005689	 7 611984 009045	 7 611984 009205
Material	Grillbürste aus Edelstahl mit Messingborsten	Grillbürste aus Edelstahl mit Messingborsten	Messingborsten	Edelstahlwolle	Deklarationsfrei (ohne toxische Substanzen)
Merkmale	im bedruckten, erklärenden Display	Mit Klinge, Bürstenkopf austauschbar	zu Grillbürste «Silvy» im Duo- Pack	ideal zum Reinigen der porzellan- emaillierten Trichter	Krustenlöser, in der Schweiz hergestellt, eignet sich auch zur Reinigung des Grillzubehörs
Bestelleinheit	24 Stück im Display	6 Stück	6 Stück	12 Stück	12er Display
<b>UVP</b>	<b>€ 4,90</b>	<b>€ 9,90</b>	<b>€ 7,90</b>	<b>€ 8,90</b>	<b>€ 9,90</b>



## Universalzubehör

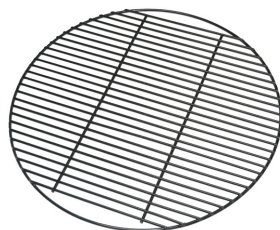

**Grillrost für Gaskugelgrill Ø 54 cm**

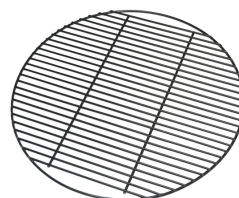

**Grillrost für Gaskugelgrill Ø 45 cm**



**Thermometer für  
OUTDOORCHEF Kugelgrills**



**Schlauch und Regler Set zu OC-Gasgrills  
bis 2011**

**ab 2011**

	<b>Grillrost Ø 54cm</b> 18.211.45	<b>Grillrost Ø 45cm</b> 18.211.43	<b>Thermometer</b> 18.211.42	<b>Schlauch &amp; Regler Set</b> 18.211.69	<b>Schlauch &amp; Regler Set</b> 18.211.81
EAN-Code					
Durchmesser	Ø 54 cm	Ø 45 cm			
für Kugelgröße	570er	480er	alle	Passend für alle OC-Gasgrills bis 2011, nicht für Grills anderer Hersteller!	Passend für alle OC-Gasgrills ab 2011
Material	Stahl, porzellanemailliert	Stahl, porzellanemailliert			
Eigenschaften	In 4 farbiger Einzel-Verkaufsverpackung	In 4 farbiger Einzel-Verkaufsverpackung	In 4 farbiger Einzel-Verkaufsverpackung		
Bestelleinheit	6 Stück	6 Stück	6 Stück	6 Stück	6 Stück
<b>UVP</b>	<b>€ 44,90</b>	<b>€ 34,90</b>	<b>€ 9,90</b>	<b>€ 19,90</b>	<b>€ 19,90</b>

## Abdeckhauben



**Abdeckhauben 2013 in neuer Farbe und neuem, robustem, wasserdichten, langlebigem Gewebe für optimalen Schutz.**



Ascona / Classic Charcoal



Leon/Ambri/Delta/  
Milano/Porto/Rover +  
Easy Charcoal 480/570



Roma MX2 / Montreux



Paris Deluxe/Paris



Venezia



Munich

Abdeckhauben						
Art-Nummer	18.221.23	18.221.24	18.221.26	18.221.27	18.221.28	18.221.32
EAN-Code						
Masse	60x115x110cm	78x53x111cm	127x45x107cm	110x68x87cm	144x75x113cm	90x65x106cm
Grillmodelle	Ascona, Classic Charcoal	Leon, Ambri, Rover 480/570 Easy Charcoal 480/570, Delta, Porto, Milano	Roma 570 MX2 Montreux 570	Paris Deluxe, Paris 570	Venezia 570	Munich
Material	widerstandsfähiges Polyestergewebe, Innenseite mit wasserundurchlässiger PVC-Beschichtung					
Bestelleinheit	6 Stück	6 Stück	6 Stück	6 Stück	6 Stück	6 Stück
UVP	€ 59,90	€ 44,90	€ 59,90	€ 69,90	€ 94,90	€ 59,90

## Abdeckhauben

**NEW**

**Abdeckhauben 2013 in neuer Farbe und neuem, robustem, wasserdichten, langlebigem Gewebe für optimalen Schutz.**



Cairns / Hamilton



Universalabdeckhaube  
large



Auckland / Wellington



Brisbane / Canberra / Perth

Abdeckhauben				
Artikel-Nummer	14.211.43	14.211.44	14.211.41	14.211.42
EAN-Code				
Masse	99x85x60cm	102x125x46cm	142x118x59cm	95x118x59cm
Grillmodelle	Cairns / Hamilton	Universal large	Auckland / Wellington	Brisbane / Canberra / Perth
Material	widerstandsfähiges Polyestergewebe, Innenseite mit wasserundurchlässiger PVC-Beschichtung			
Bestelleinheit	6 Stück	6 Stück	6 Stück	6 Stück
<b>UVP</b>	<b>€ 34,90</b>	<b>€ 39,90</b>	<b>€ 49,90</b>	<b>€ 39,90</b>

## Neuheiten 2013



**Gusseisenrost Ø 45 cm**  
2-teilig



**Gusseisenrost Ø 54 cm**  
2-teilig



**Gusseisenrost Ø 45 cm**  
1-teilig



**Gusseisenrost Ø 54 cm**  
1-teilig

	<b>Gusseisenrost für 480-er Grills 2-teilig 18.211.76</b>	<b>Gusseisenrost für 570-er Grills 2-teilig 18.211.77</b>	<b>Gusseisenrost für 480-er Grills 1-teilig 18.211.78</b>	<b>Gusseisenrost für 570-er Grills 1-teilig 18.211.79</b>
EAN-Code	 7 611984 011925	 7 611984 011949	 7 611984 011963	 7 611984 011987
Material	Hitzebeständig beschichteter Gusseisenrost mit Grillplatteneinsatz	Hitzebeständig beschichteter Gusseisenrost mit Grillplatteneinsatz	Hitzebeständig beschichteter Gusseisenrost	Hitzebeständig beschichteter Gusseisenrost
Merkmale	Ideal zum Grillen mit starkem Branding	Ideal zum Grillen mit starkem Branding	Ideal zum Grillen mit starkem Branding	Ideal zum Grillen mit starkem Branding
Bestelleinheit	3 Stück	3 Stück	3 Stück	3 Stück
<b>UVP</b>	<b>€ 59,90</b>	<b>€ 69,90</b>	<b>€ 49,90</b>	<b>€ 59,90</b>



## Neuheiten 2013



**Bambus Schneidebrett**



**3-Finger-Silikon Handschuh**  
schwarz



**Silikon Topflappen**  
schwarz



**Grillkochbuch „Der Outdoorchef“**

	<b>Bambus Schneidebrett</b> 14.112.48	<b>3-Finger Silikon Handschuh schwarz</b> 14.491.23	<b>Silikon Topflappen schwarz</b> 14.491.24	<b>„Der Outdoorchef“ Grillkochbuch</b> 14.410.14
EAN-Code				
Material	Umweltfreundliches Bambus Holz aus verantwortungsvollem Anbau	Silikon	Silikon	
Merkmale	Mit großer Safrille, Abmessung 50x30x2,5cm	Bis 300° Hitzebeständig	Bis 230° Hitzebeständig	für Gaskugelgrills
Bestelleinheit	6 Stück	6 Stück	6 Stück	10 Stück
<b>UVP</b>	<b>€ 49,90</b>	<b>€ 19,90</b>	<b>€ 11,90</b>	<b>€ 29,90</b>

## Übersicht Seite 38 - 86

- UVP Preisliste 2013 .....	S. 38, 39
- Explosionszeichnungen	
○ Ambri.....	S. 40, 41
○ Ascona .....	S. 42, 43
○ City Grill Tripod .....	S. 44, 45
○ Delta .....	S. 46, 47
○ Geneva .....	S. 48, 49
○ Leon.....	S. 50, 51
○ Montreux .....	S. 52, 53
○ Munich .....	S. 54, 55
○ Paris Deluxe.....	S. 56, 57
○ Porto.....	S. 58, 59
○ Venezia .....	S. 60, 61
○ Auckland.....	S. 62, 63
○ Cairns.....	S. 64, 65
○ Canberra.....	S. 66, 67
○ Hamilton.....	S. 68, 69
○ Perth.....	S. 70, 71
○ City Charcoal .....	S. 72, 73
○ Classic Charcoal .....	S. 74, 75
○ Easy Charcoal 480 .....	S. 76, 77
○ Easy Charcoal 570 .....	S. 78, 79
○ Rover 480 .....	S. 80, 81
○ Rover 570 .....	S. 82, 83
○ City Elektro .....	S. 84
- Index .....	S. 85, 86

## UVP-Preisliste Deutschland-Österreich 2013

Art.Nr.	VE	EAN	Bezeichnung	Größe	Farbe	PE	UVP €
<b>Cubic Line - Gaskugelgrills</b>							
18.127.31	1	7611984009304	Venezia ***	570	onyx	2	1.149,00 €
18.127.15	1	7611984008925	Paris ***	570	onyx	2	899,00 €
18.127.26	1	7611984009274	Munich ***	480	onyx	2	549,00 €
<b>Classic Line - Gaskugelgrills</b>							
N 18.127.37	1	7611984010379	Geneva ***	570	schwarz	2	799,00 €
18.127.09	1	7611984008451	Montreux ***	570	schwarz	3	699,00 €
18.127.24	1	7611984009236	Ascona ***	570	ruby	3	579,00 €
18.127.11	1	7611984008475	Ascona ***	570	schwarz	3	549,00 €
18.127.42	1	7611984009953	Ascona ***	570	schwarz	3	549,00 €
18.127.22	1	7611984009212	Ambri	480	ruby	8	429,00 €
18.127.01	1	7611984008185	Ambri	480	schwarz	8	399,00 €
<b>Base Line - Gaskugelgrills</b>							
18.127.19	1	7611984009069	Leon ***	570	vanilla	3	429,00 €
18.127.21	1	7611984009083	Leon ***	570	schwarz	3	429,00 €
18.126.58	1	7611984007256	Delta	480	onyx	8	329,00 €
18.127.28	1	7611984009243	Porto	480	schwarz	8	279,00 €
N 18.127.78	1	7611984010805	Citygrill Tripod	420	vanilla	10	179,00 €
N 18.127.45	1	7611984010324	Citygrill Tripod	120	schwarz	10	169,00 €
<b>Australian Line - Gasgrills</b>							
18.131.23	1	7611984009915	Auckland ***	4 Brenner	Edelstahl 304	3	799,00 €
18.131.19	1	7611984009878	Perth ***	4 Brenner	schwarz	3	599,00 €
18.131.17	1	7611984009854	Canberra ***	4 Brenner	schwarz	4	499,00 €
18.131.15	1	7611984009830	Hamilton ***	3 Brenner	schwarz	6	449,00 €
18.131.13	1	7611984009816	Cairns ***	3 Brenner	schwarz	6	399,00 €
<b>Charcoal Line - Holzkohlegrills</b>							
18.125.38	1	7611984010263	Classic Charcoal ***	570	schwarz	4	369,00 €
18.125.37	1	7611984010256	Rover 570 ***	570	schwarz	6	269,00 €
18.125.36	1	7611984010249	Rover 480	480	schwarz	6	229,00 €
18.125.35	1	7611984010232	Easy Charcoal	570	schwarz	8	179,00 €
18.125.34	1	7611984010225	Easy Charcoal	480	schwarz	8	149,00 €
18.125.33	1	7611984010218	City Charcoal	420	schwarz	10	99,00 €
<b>Electric Line - Elektrogrills</b>							
18.130.07	1	7611984010287	City Electro	420	schwarz	10	199,00 €
<b>Abdeckhauben Grills und Gasflaschen</b>							
N 14.211.43	6	7611984011833	Abdeckhaube Cairns/Hamilton grau	Australian			34,90 €
N 14.211.44	6	7611984011857	Abdeckhaube Universal Large grau	Universal			39,90 €
N 14.211.41	6	7611984011512	Abdeckhaube Auckland/Wellington grau	Australian			49,90 €
N 14.211.42	6	7611984011536	Abdeckhaube Brisbane grau	Australian			39,90 €
N 18.221.23	6	7611984011550	Abdeckhaube Ascona 570, CC 570 MX grau	System 570			59,90 €
N 18.221.24	6	7611984011574	Abdeckhaube 480, Leon, Easy/Rover 570, Geneva grau	System 480/570			44,90 €
N 18.221.25	6	7611984011598	Abdeckhaube City Grill Linie (Gas/Kohle/Electro) grau	System 420			24,90 €
N 18.221.26	6	7611984011611	Abdeckhaube Roma, Montreux grau	System 570			59,90 €
N 18.221.27	6	7611984011635	Abdeckhaube Paris, Paris DeLuxe grau	System 570			69,90 €
N 18.221.28	6	7611984011659	Abdeckhaube Venezia grau	System 570			94,90 €
N 18.221.32	6	7611984011673	Abdeckhaube Munich 480 grau	System 480			59,90 €
18.221.29	6	7611984007836	Tragetasche zu City Gas 420	System 420			29,90 €



## UVP-Preisliste Deutschland-Österreich 2013

Art.Nr.	VE	EAN	Bezeichnung	Größe	Farbe	PE	UVP €
<b>Systemzubehör</b>							
N	14.112.47	6	7611984011505	Pizzaschaufel	Universal		19,90 €
	14.331.07	6	7611984010034	Drehkorb-Set mit Motor	Universal		89,90 €
	14.410.12	10	9783037802069	Grill-Kochbuch 'Grillspass heute' (solange Vorrat reicht)	Universal		11,90 €
	14.410.14	10	9783037804704	Grill-Kochbuch "Der OUTDOORCHEF"	Universal		29,90 €
	18.211.06	6	7611984001261	Grillrost klein 34cm	System 480/570		16,90 €
	18.211.22	6	7611984005948	Universalpfanne 46cm	System 570		49,90 €
	18.211.24	3	7611984006976	Gusseisenplatte "Plancha" 39cm	System 480/570		59,90 €
	18.211.25	3	7611984006983	Gusseisenplatte "Plancha" 33cm	System 420-570		49,90 €
	18.211.27	6	7611984007010	Pizza- und Backblech 40cm	System 480/570		22,90 €
	18.211.29	6	7611984007058	Gourmet-Set (Universalpfanne/Pizzablech) 480/570er	System 480/570		49,90 €
	18.211.32	6	7611984007683	Gourmet-Set City Grill (Universalpfanne/Pizzablech) 420er	System 420-570		39,90 €
	18.211.39	6	7611984008215	Wok aus Gusseisen 35cm	System 480/570		49,90 €
	18.211.40	3	7611984008611	Pfanne aus Gusseisen 38cm	System 480/570		59,90 €
	18.211.41	6	7611984008628	Back- und Kuchenblech 30cm	System 420-570		22,90 €
	18.211.50	6	7611984009021	Aroma Pfanne aus Gusseisen 23cm	System 420-570		24,90 €
	18.211.51	6	7611984009038	Gourmet Halbmond 2 teilig	System 480/570		44,90 €
	18.211.54	3	7611984009939	Pizza- und Brotbackstein 32cm	System 420-570		59,90 €
N	18.211.61	3	7611984010935	Pizza- und Brotbackstein 41cm	System 480/570		79,90 €
N	18.211.76	3	7611984011925	Gusseisenrost für 480er Kugelgrills 2-teilig	System 480		59,90 €
N	18.211.77	3	7611984011949	Gusseisenrost für 570er Kugelgrills 2-teilig	System 570		69,90 €
N	18.211.78	3	7611984011963	Gusseisenrost für 480er Kugelgrills 1-teilig	System 480		49,90 €
N	18.211.79	3	7611984011987	Gusseisenrost für 570er Kugelgrills 1-teilig	System 570		59,90 €
	18.221.22	3	7611984008789	Abdeckkorb für Gasflaschen aus Poly Rattan	Universal		59,90 €
	18.291.05	6	7611984004392	Deckelhalter für Kugelgrills 480 und 570	System 480/570		14,90 €
	18.291.07	6	7611984004910	Seitenablage für Kugelgrill 480	System 480		39,90 €
	18.291.08	6	7611984004927	Seitenablage für Kugelgrill 570	System 570		49,90 €
	18.291.15	6	7611984007751	Tripod zu City Gas	System 420		34,90 €
N	18.211.74	6	7611984011178	Alu-Schutzfolie zu Hitzereflektor	System 420		9,90 €
N	18.291.23	6	7611984011802	Kralle zum City Grill 420	System 420		34,90 €
<b>Universalzubehör</b>							
	14.112.18	6	7611984004941	Grillbesteckset Royal 3-teilig	Universal		32,90 €
	14.112.23	6	7611984005092	Grillpinzette	Universal		19,90 €
	14.112.24	6	7611984005108	Grillschürze OUTDOORCHEF	Universal		14,90 €
	14.112.35	6	7611984008314	Grillzange "Quick Lock"	Universal		14,90 €
	14.112.36	12	7611984008321	Gourmet Spatula	Universal		18,90 €
	14.112.40	3	7611984009922	Gusseisenplatte "Plancha" rechteckig	Universal		69,90 €
N	14.112.48	6	7611984011741	Bambus Schneidebrett (50x30x2,5cm)	Universal		49,90 €
N	14.212.07	6	7611984011710	Abdeckhaube für Gasflaschen	Universal		14,90 €
	14.421.11	24	7611984004996	Grillbürste "Lucy" im 24-er Display	Universal		4,90 €
	14.421.12	6	7611984005559	Grillbürste "Silvy"	Universal		9,90 €
	14.421.13	6	7611984005689	Ersatzkopfset zu Grillbürste "Silvy"	Universal		7,90 €
	14.421.16	12	7611984009205	BBQ Cleaner	Universal		9,90 €
	14.491.10	12	7611984003838	Grill Lederhandschuhe (Paar)	Universal		19,90 €
	14.491.16	6	7611984006464	Gourmet Check Bratenthermometer	Universal		34,90 €
N	14.491.22	6	7611984011765	Lederhandschuhe Grösse M grau	Universal		19,90 €
N	14.491.23	6	7611984011796	3-Finger Silikon Handschuh BBQ schwarz	Universal		19,90 €
N	14.491.24	6	7611984012007	Silikon Topflappen schwarz	Universal		11,90 €
	18.211.42	6	7611984008666	Thermometer für OUTDOORCHEF Kugelgrills	Universal		9,90 €
	18.211.43	6	7611984008673	Grillrost für Gaskugelgrill 480	Universal		34,90 €
	18.211.45	6	7611984008680	Grillrost für Gaskugelgrill 570	Universal		44,90 €
	18.211.52	12	7611984009045	Reinigungsbürste "Fredy"	Universal		8,90 €
N	18.211.69	6	7611984011093	Gasschlauch & Druckregler Set bis Modelljahr 2010 (5/8")	Universal		19,90 €
N	18.211.81	6	7611984012021	Gasschlauch & Druckregler Set ab Modelljahr 2011 (1/4")	Universal		19,90 €

UVP: unverbindliche Verkaufspreisempfehlung inkl. gesetzlich gültiger MwSt.

N: Neuheit

VE: Verpackungseinheit

PE: Paletteneinheit

Es gelten ferner die aktuellen Liefer- und Zahlungskonditionen gemäss Konditionsblatt 2013.

Die hier angeführten Preise haben Gültigkeit vom 01.01.2013 bis zum 31.12.2013. Irrtümer und Fehler vorbehalten.



# Ambri

## Spare Parts

## Ersatzteil-Liste

Pos. Art. Nr.	Description	Beschreibung
1	18.350.50	Lid black LH
1	18.350.51	Lid ruby LH
2	18.323.06	Lid handle EC style titan-silver
3	18.323.00	Heat Shield
4	18.322.20	Lid hinge complete
5	18.360.29	Upper lid hinge cover
6	18.360.30	Lower lid hinge cover
7	18.850.13	Heat indicator °C/°F
8	18.850.12	Heat indicator-Nut
9	18.320.01	Cooking grid
10	18.320.04	Large Funnel
11	18.320.03	Small Funnel
12	18.340.01	Burner
13	18.350.35	Bowl black LH
13	18.350.44	Bowl ruby LH
14	18.321.98	Control panel SB titan-silver
15	18.360.20	Control knob
16	18.340.47	Valve assembly with bundy
17	18.340.16	Injector 30mbar mark: BN
18	18.340.15	Injector 50mbar mark: AN
19	18.340.07	Pulse ignitor SB complete
20	18.360.21	Push button ignitor
21	18.340.57	Venturiprotection
22	18.340.09	Piezo electrode
23	18.340.12	Ignition wire
24	18.323.04	Drip pan
25	18.323.05	Drip pan carrier
26	18.321.91	X-Module titan-silver
27	18.321.92	Trolley front bottom titan-silver
28	18.321.93	Trolley front top titan-silver
29	18.321.94	Trolley wheel side bottom titan-silver
30	18.321.95	Trolley wheel side top titan-silver
31	18.365.03	End Cap
32	18.323.07	Axle titan-silver
33	18.360.38	Wheel
34	18.360.39	Wheel cover
35	18.360.44	Liner wheel
36	18.310.04	Bottom shelf nature
36	18.310.18	Bottom shelf black
37	18.360.11	Bottle fixation strap
38	18.310.15	Front table nature
38	18.310.19	Front table black
39	18.321.10	Gas hose Hook
39	18.378.90	Hardware set
40	18.322.23	Tool holder
41	individual	Gas hose
42	individual	Gas Regulator

### Attention

Please write your serial number on the backside of the manual for future reference. You will find the number on the data plate attached to the trolley or the bottom plate depending on the grill model. OUTDOORCHEF can only supply spare parts and honour warranty returns when the serial number is available.

### Achtung

Bitte notieren Sie auf der Rückseite Ihrer Gebrauchsanweisung die Serien-Nummer. Je nach Grillmodell finden Sie die Nummer auf dem Datensticker, welcher sich entweder am Grillgestell oder auf der Bodenplatte befindet. OUTDOORCHEF kann Garantie und Ersatzteil-lieferungen nur mit der Serien-Nummer bearbeiten.

# Ambri



THE BARBECUE COMPANY

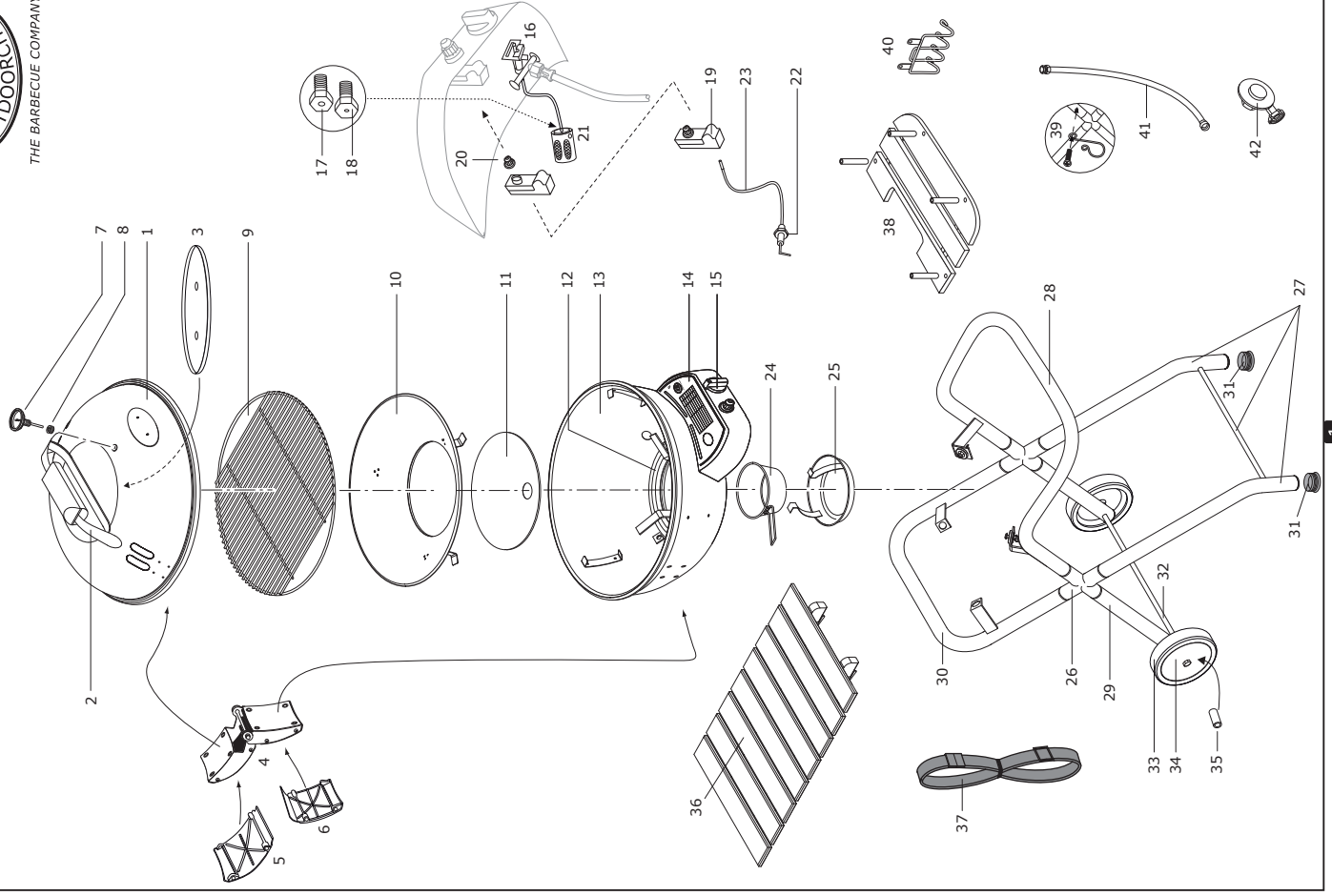

Pos.	Art. Nr.	Description
B		Lid
		Beschreibung
B1	18.370.93	Protection washer lid handle
B2	18.370.76	Teflonwasher
B3	18.370.62	Washer
B4	18.370.43	Nut

Pos.	Art. Nr.	Description
C		Lid Hinge
		Beschreibung
C1	18.332.42	Lid hinge axle
C2	18.370.40	Dome Nut
C3	18.370.63	Washer
C4	18.370.76	Teflonwasher
C5	18.370.28	Lid hinge cover screw

Pos.	Art. Nr.	Description
D		Valve assembly & Console
		Beschreibung
D1	18.370.05	Screw
D2	18.371.01	Screw
D3	18.371.02	Washer
D4	18.371.03	Teflonwasher
D5	18.370.86	Teflonwasher
D6	18.371.00	Screw

Pos.	Art. Nr.	Description
E		Bowl
		Beschreibung
E1	18.370.10	Screw
E2	18.370.62	Washer
E3	18.370.76	Teflonwasher
E4	18.370.91	Protection washer bowl
E5	18.370.68	Washer
E6	18.370.44	Wing nut

Pos.	Art. Nr.	Description
F		Piezo electrode
		Beschreibung
F1	18.371.01	Screw
F2	18.371.02	Washer
F3	18.371.03	Teflonwasher
F4	18.371.04	Spring washer
F5	18.370.48	Nut
F6	18.371.11	Holder piezo electrode

Pos.	Art. Nr.	Description
G		Side Tablar & Bottom shelf
		Beschreibung
G1	18.371.05	Woodscrew

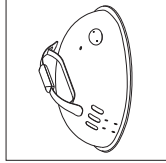

B

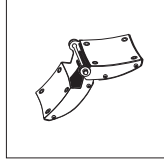
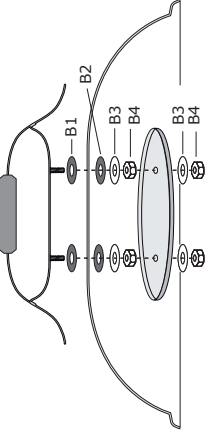

C

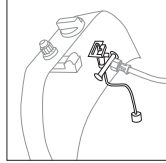
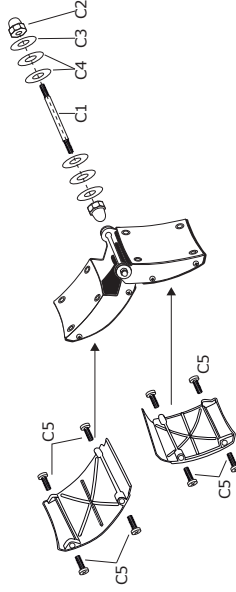

D

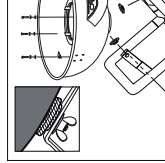
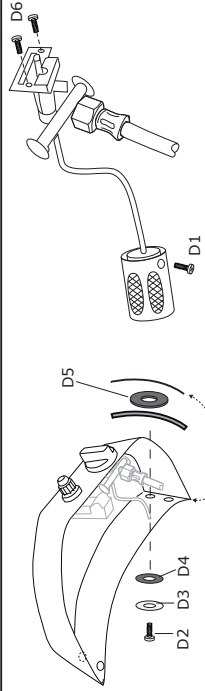

E

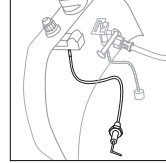
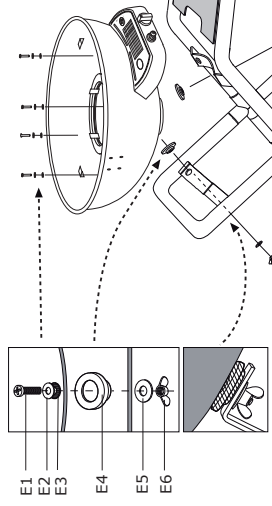

F

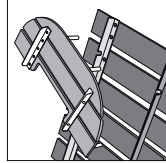
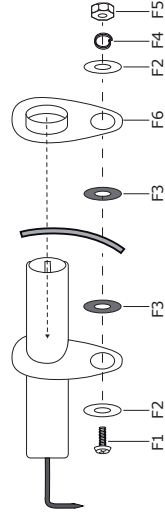

G

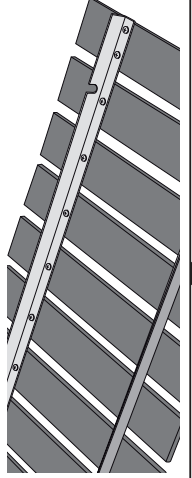
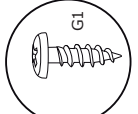

# Ascona

## Spare Parts

Pos.	Art. Nr.	Description	Beschreibung
1	18.350.54	Lid blue 570 LH	Deckel blau 570 LH
1	18.350.49	Lid black 570 LH	Deckel schwarz 570 LH
1	18.350.57	Lid ruby 570 LH	Deckel ruby 570 LH
2	18.322.73	Lid handle titan-silver	Deckelgriff titan-silber
3	18.323.00	Heat shield	Hitzeschild
4	18.322.21	Lid hinge titan-silver complete	Deckelscharnier titan-silber Komplett
5	18.360.31	Upper lid hinge cover	Deckelscharnier-Abdeckung oben
6	18.360.32	Lower lid hinge cover	Deckelscharnier-Abdeckung unten
7	18.850.13	Heat indicator °C/°F	Temperatur Anzeige °C/°F
8	18.850.14	Frame for heat indicator	Rahmen zu Temperaturanzeiger
9	18.850.12	Heat indicator-Nut	Temperaturanzeiger-Befestigungsmutter
10	18.320.00	Cooking grid	Grillrost
11	18.320.02	Large Funnel	Grosser Trichter
12	18.320.03	Small Funnel	Kleiner Trichter
13	18.350.13	Bowl blue LH DB Ph	Kugel blau LH DB Ph
13	18.350.19	Bowl black LH DB Ph	Kugel schwarz LH DB Ph
13	18.350.46	Bowl ruby LH DB Ph	Kugel ruby LH DB Ph
14	18.360.20	Control knob	Gasregulier-Knopf
15	18.322.04	Control panel DB titan-silver	Bedienkonsole DB titan-silber
16	18.340.49	Valve assembly with bundy DB	Ventilsatz mit bundy DB
17	18.340.14	Injector small burner 30mbar mark: BF	Düse für kleiner Brenner 30mbar mark: BF
18	18.340.13	Injector small burner 50mbar mark: AF	Düse für kleiner Brenner 50mbar mark: AF
19	18.340.18	Injector large burner 30mbar mark: BF	Düse für grossen Brenner 30mbar mark: BF
20	18.340.17	Injector large burner 50mbar mark: AF	Düse für grossen Brenner 50mbar mark: AF
21	18.340.58	Venturi-protection DB small	Venturischutz DB klein
22	18.340.57	Venturi-protection DB & SB	Venturischutz DB & SB
23	18.340.08	Pulse ignitor DB complete	Elektro- Zündung DB
24	18.360.21	Push button ignitor	Druckknopf Zündung
25	18.340.02	Burner small 30mbar	Brenner klein 30mbar
25	18.340.45	Burner small 50mbar	Brenner klein 50mbar
26	18.340.00	Burner large 30mbar	Grosser Brenner 30mbar
26	18.340.44	Burner large 50mbar	Grosser Brenner 50mbar
27	18.340.12	Ignition wire	Zündungskabel
28	18.340.11	Piezo electrode large burner	Piezo- Elektrode grosser Brenner
29	18.340.10	Piezo electrode small burner	Piezo- Elektrode kleiner Brenner
30	18.323.04	Drip pan	Fettauffangschale
31	18.323.05	Drip pan carrier	Fettauffangschale Halterung
32	18.322.05	X-Module titan-silver	X-Modul titan-silber
33	18.322.99	Stand-Modul titan-silver	Stand-Modul titan-silber
34	18.322.14	Table-Module titan-silver	Tablar-Modul titan-silber
35	18.322.08	Wheel-Modul left titan-silver	Rad-Module links titan-silber
36	18.322.09	Wheel-Modul right titan-silver	Rad-Modul rechts titan-silber
37	18.322.10	Connection-Modul titan-silver	Verbindungs-Modul titan-silber
38	18.323.11	Axle titan-silver	Radachse, Titan-Silber
39	18.322.12	Bottle fixation bar titan-silver	Flaschenhalterungsstrebe titan-silber
40	18.360.11	Bottle fixation strap	Flaschenhalterungs-Gurt
41	18.310.01	Bottom shelf nature	Bodenrost natur
41	18.310.20	Bottom shelf black	Bodenrost schwarz
42	18.310.07	Front table nature	Fronttابلar natur
42	18.310.21	Front table black	Fronttابلar schwarz
43	18.360.05	Wheel	Rad
44	18.360.40	Wheel cover	Radabdeckung
45	18.360.45	Liner wheel	Laufbuchse
46	18.360.37	Height adjustment	Höhenverstellung
47	18.320.21	Tool holder	Besteck-Halter
48	18.321.10	Gas hose Hook	Gasschlauch-Haken
49	18.378.93	Hardware Set	Schrauben Set
49	individual	Gas hose	Gasschlauch
50	individual	Gas regulator	Gasdruckregler

### Attention

Please write your serial number on the backside of the manual for future reference. You will find the number on the data plate attached to the trolley or the bottom plate depending on the grill model. OUTDOORCHEF can only supply spare parts and honour warranty returns when the serial number is available.

# Ascona



THE BARBECUE COMPANY

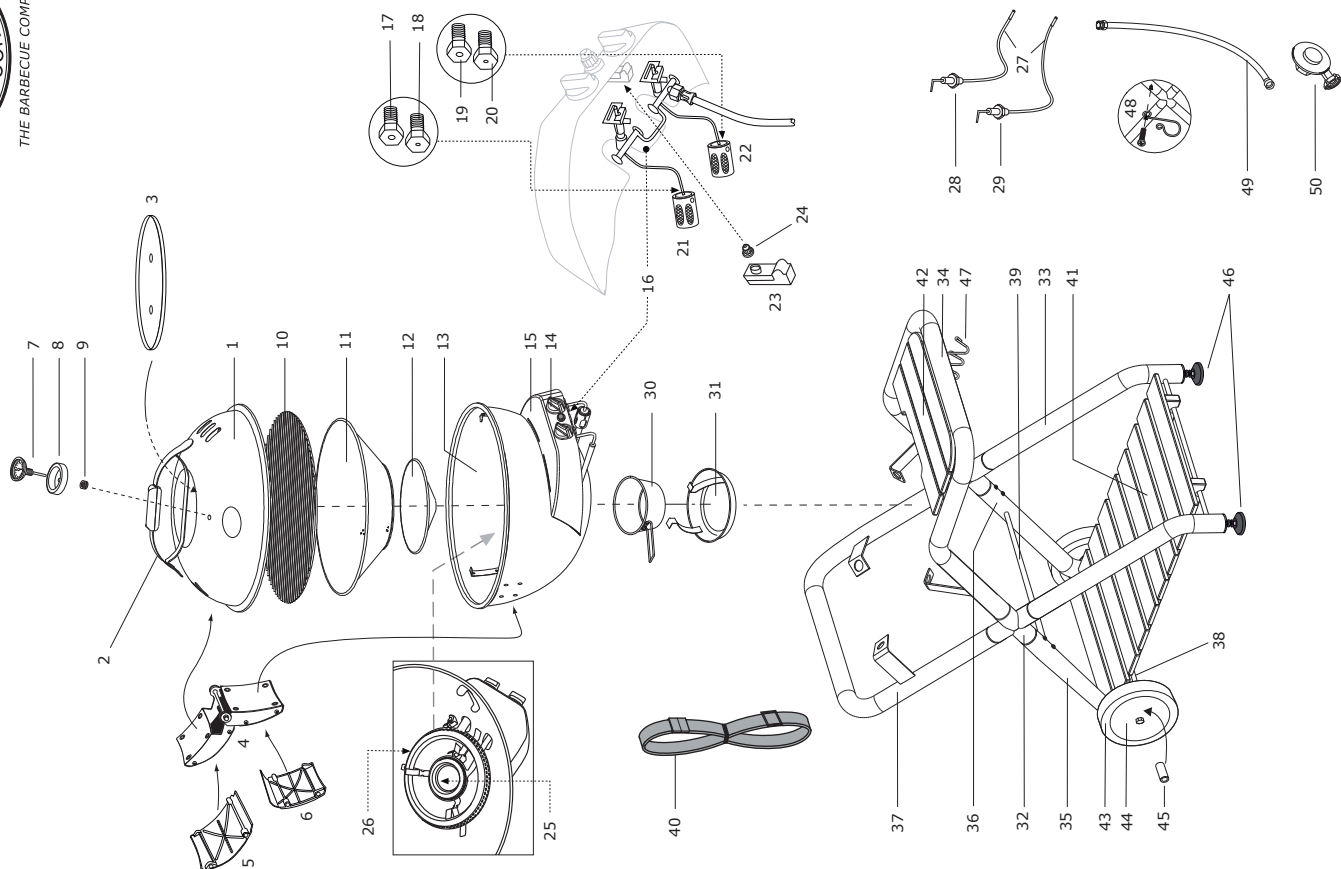

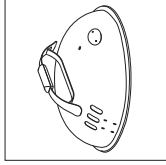

**B**

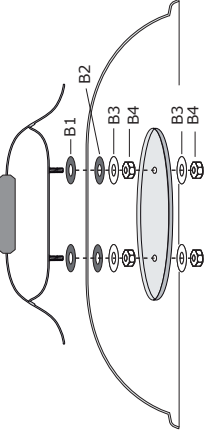

Pos.	Art. Nr.	Description
B		Deckel
		Beschreibung
B1	18.370.90	Protection washer lid handle
B2	18.370.76	Teflonwasher
B3	18.370.62	U-Scheibe
B4	18.370.43	Nut

Pos.	Art. Nr.	Description
C		Deckelscharnier
		Beschreibung
C1	18.332.27	Lid hinge axle
C2	18.370.40	Dome Nut
C3	18.370.63	Washer
C4	18.370.76	Teflonwasher
C5	18.370.28	Lid hinge cover screw

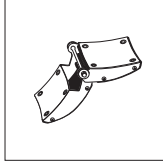

**C**

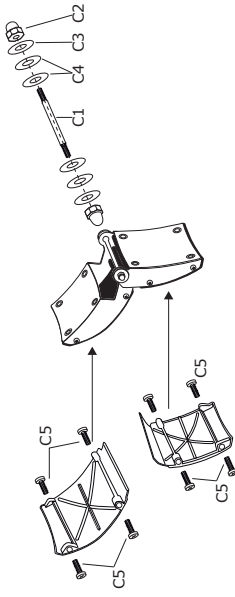

Pos.	Art. Nr.	Description
D		Valve assembly & Console
		Beschreibung
D1	18.370.05	Screw
D2	18.371.01	Schraube
D3	18.371.02	Washer
D4	18.371.03	Teflonwasher
D5	18.370.86	Teflonwasher
D6	18.371.00	Screw

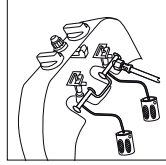

**D**

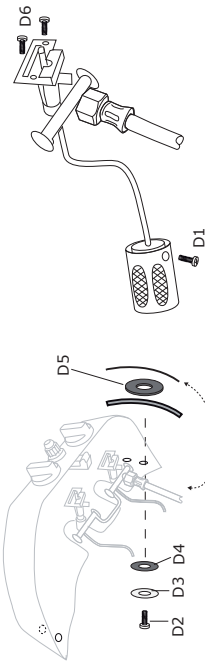

Pos.	Art. Nr.	Description
E		Bowl
		Beschreibung
E1	18.370.10	Screw
E2	18.370.62	Washer
E3	18.370.76	Teflonwasher
E4	18.370.91	Washer Alu.
E5	18.370.68	Washer
E6	18.370.44	Wing nut

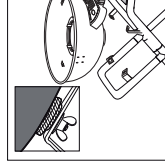

**E**

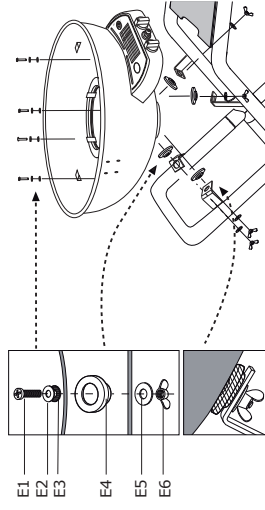

Pos.	Art. Nr.	Description
F		Piezo electrode
		Beschreibung
F1	18.371.01	Schraube
F2	18.371.02	Washer
F3	18.371.03	Teflonwasher
F4	18.371.04	Spring washer
F5	18.370.48	Nut
F6	18.371.11	Holder piezo electrode

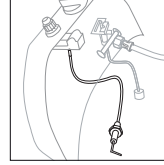

**F**

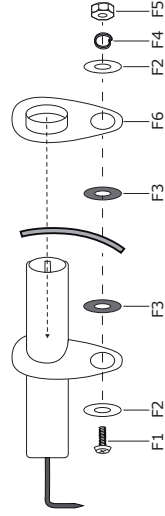

Pos.	Art. Nr.	Description
G		Side Tablar & Bottom shelf
		Beschreibung
G1	18.371.05	Woodscrew

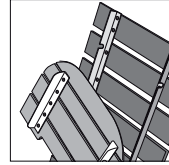

**G**

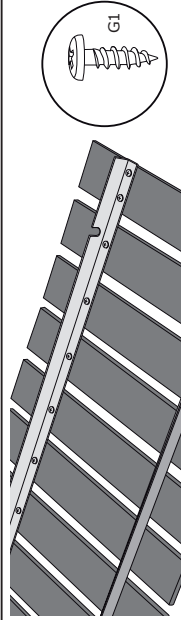



# CITY GRILL TRIPOD



THE BARBECUE COMPANY

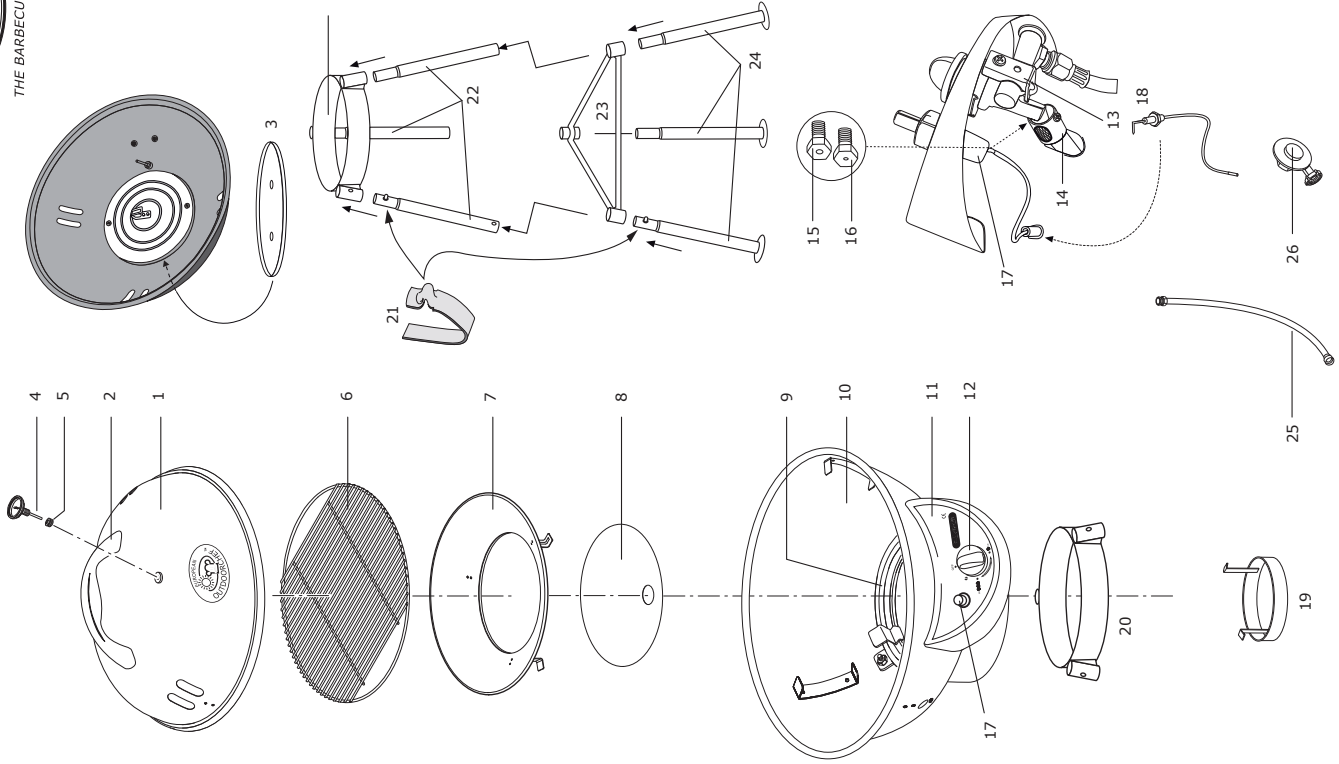

1

## CITY GRILL TRIPOD

### Spare Parts

### Ersatzteil-Liste

Pos.	Art. Nr.	Description	Beschreibung
1	18.350.56	Lid black	Deckel schwarz
1	18.350.61	Lid vanilla	Deckel vanilla
2	18.360.16	Lid handle orange	Deckelgriff schwarz
2	18.360.46	Lid handle black	Deckelgriff schwarz
3	18.323.21	Heat Shield	Hitzeschild
4	18.850.13	Heat indicator °C/°F	Temperaturanzeiger °C/°F
5	18.850.12	Heat indicator -Nut	Temperaturanzeiger-Befestigungsmutter
6	18.321.40	Cooking grid	Grillrost
7	18.321.41	Large Funnel	Grosser Trichter
8	18.321.42	Small Funnel	Kleiner Trichter
9	18.340.36	Burner	Brenner
10	18.350.31	Bowl black	Kugel schwarz
10	18.350.63	Bowl vanilla	Kugel Vanilla
11	18.321.43	Control panel black	Bedienungskonsole schwarz
12	18.360.26	Control knob	Gasregulier-Knopf
13	18.340.61	Valve assembly	Ventilsatz
14	18.340.59	Venturiprotection	Venturischutz
15	18.340.27	Injector 30mbar mark: BL	Düse 30mbar mark: BL
16	18.340.26	Injector 50mbar mark: AH	Düse 50mbar mark: AH
17	18.340.31	Piezo ignitor	Piezo-Zündung
18	18.340.30	Piezo electrode	Piezo-Elektrode
19	18.321.44	Drip pan	Fettauffangschale
20	18.321.49	Bowl fixation black	Kugelfixierung schwarz
21	18.323.22	Fixation clip	Fixierungsbügel
22	18.321.50	Legs upper part black	Bein Oberenteil schwarz
23	18.321.51	Stabilisation black	Stabilisation schwarz
24	18.321.52	Legs lower part black	Bein Unterteil schwarz
25	individual	Gas hose	Gasschlauch
26	individual	Gas regulator	Gasdruckregler

### Attention

Please write your serial number on the backside of the manual for future reference. You will find the number on the data plate attached to the trolley or the bottom plate depending on the grill model. OUTDOORCHEF can only supply spare parts and honour warranty returns when the serial number is available.

### Achtung

Bitte notieren Sie auf der Rückseite Ihrer Gebrauchsanweisung die Serien-Nummer. Je nach Grillmodell finden Sie die Nummer auf dem Datensticker, welcher sich entweder am Grillgestell oder auf der Bodenplatte befindet. OUTDOORCHEF kann Garantie und Ersatzteil-lieferungen nur mit der Serien-Nummer bearbeiten.



# CITY GRILL TRIPOD

B	Lid
Pos.	Description
B1	Screw

D	Valve assembly & Panel
Pos.	Description
D1	Screw
D2	Screw
D3	Washer
D4	Teflonwasher
D5	Teflonwasher
D6	Screw

F	Piezo electrode
Pos.	Description
F1	Screw
F2	Washer
F3	Teflonwasher
F4	Spring washer
F5	Nut
F6	Holder piezo electrode

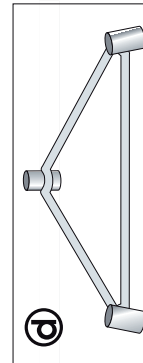
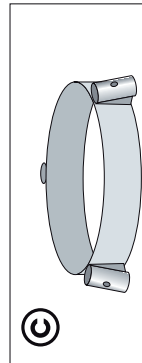
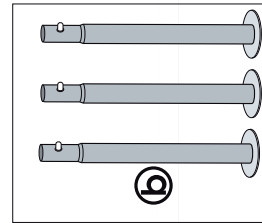
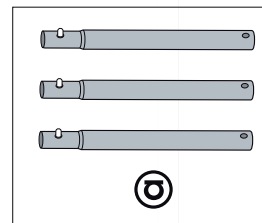

# CITY GRILL TRIPOD



THE BARBECUE COMPANY

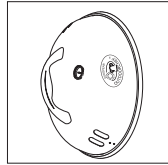

**B**

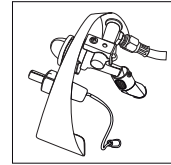

**D**

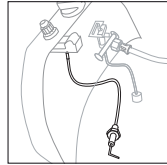

**F**

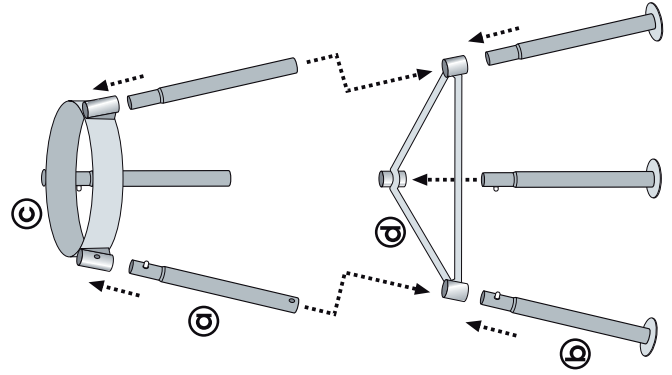

**3**

# Delta

## Spare Parts

## Ersatzteil-Liste

Pos. Art. Nr.	Description	Beschreibung	
1	18.350.52	Lid onyx	Deckel onyx
2	18.323.06	Lid handle EC style titan-silver	Deckelgriff EC style titan-silber
3	18.323.00	Heat Shield	Hitzeschild
4	18.850.13	Heat indicator °C/°F	Temperatur Anzeiger °C/°F
5	18.850.12	Heat indicator-Nut	Temperaturanzeiger-Befestigungsmutter
6	18.320.01	Cooking grid	Grillrost
7	18.320.04	Large Funnel	Grosser Trichter
8	18.320.03	Small Funnel	Kleiner Trichter
9	18.340.01	Burner	Brenner
10	18.350.33	Bowl onyx	Kugel onyx
11	18.321.98	Control panel SB titan-silver	Bedienungskonsole SB titan-silber
12	18.360.20	Control knob	Gasregulier-Knopf
13	18.340.47	Valve assembly with bundy	Ventilsatz mit bundy
14	18.340.16	Injector 30mbar mark: BN	Düse 30mbar mark: BN
15	18.340.15	Injector 50mbar mark: AN	Düse 50mbar mark: AN
16	18.340.07	Pulse Ignitor SB complete	Elektro Zündung SB Komplett
17	18.360.21	Push button ignitor	Druckknopf Zündung
18	18.340.57	Venturiprotection	Venturischutz
19	18.340.09	Piezo electrode	Piezo Elektrode
20	18.340.12	Ignition wire	Zündungskable
21	18.323.04	Drip pan	Fettauffangsschale
22	18.323.05	Drip pan carrier	Fettauffangsschale Halterung
23	18.321.99	Legs upper part titan-silver	Beine Oberteil titan-silber
24	18.323.09	Leg lower part front right titan-silver	Bein Unterteil vorne rechts titan-silber
25	18.323.10	Leg lower part front left titan-silver	Bein Unterteil vorne links titan-silber
26	18.322.02	Leg lower part rear titan-silver	Bein Unterteil hinten titan-silber
27	18.322.24	Bottom shelf titan-silver	Bodenplatte titan-silber
28	18.360.38	Wheel	Rad
29	18.360.39	Wheel cover	Radabdeckung
30	18.360.44	Linear wheel	Laufbucse
31	18.360.19	Caster with brake	Lenkrolle mit Bremse
32	18.320.19	Tool holder	Besteck-Halter
33	18.378.91	Hardware set	Schrauben Set
34	individual	Gas hose	Gasschlauch
34	individual	Gas regulator	Gasdruckregler

### Attention

Please write your serial number on the backside of the manual for future reference. You will find the number on the data plate attached to the trolley or the bottom plate depending on the grill model. OUTDOORCHEF can only supply spare parts and honour warranty returns when the serial number is available.

### Achtung

Bitte notieren Sie auf der Rückseite Ihrer Gebrauchsanweisung die Serien-Nummer. Je nach Grillmodell finden Sie die Nummer auf dem Datensticker, welcher sich entweder am Grillgestell oder auf der Bodenplatte befindet. OUTDOORCHEF kann Garantie und Ersatzteil-lieferungen nur mit der Serien-Nummer bearbeiten.



# Delta



THE BARBECUE COMPANY

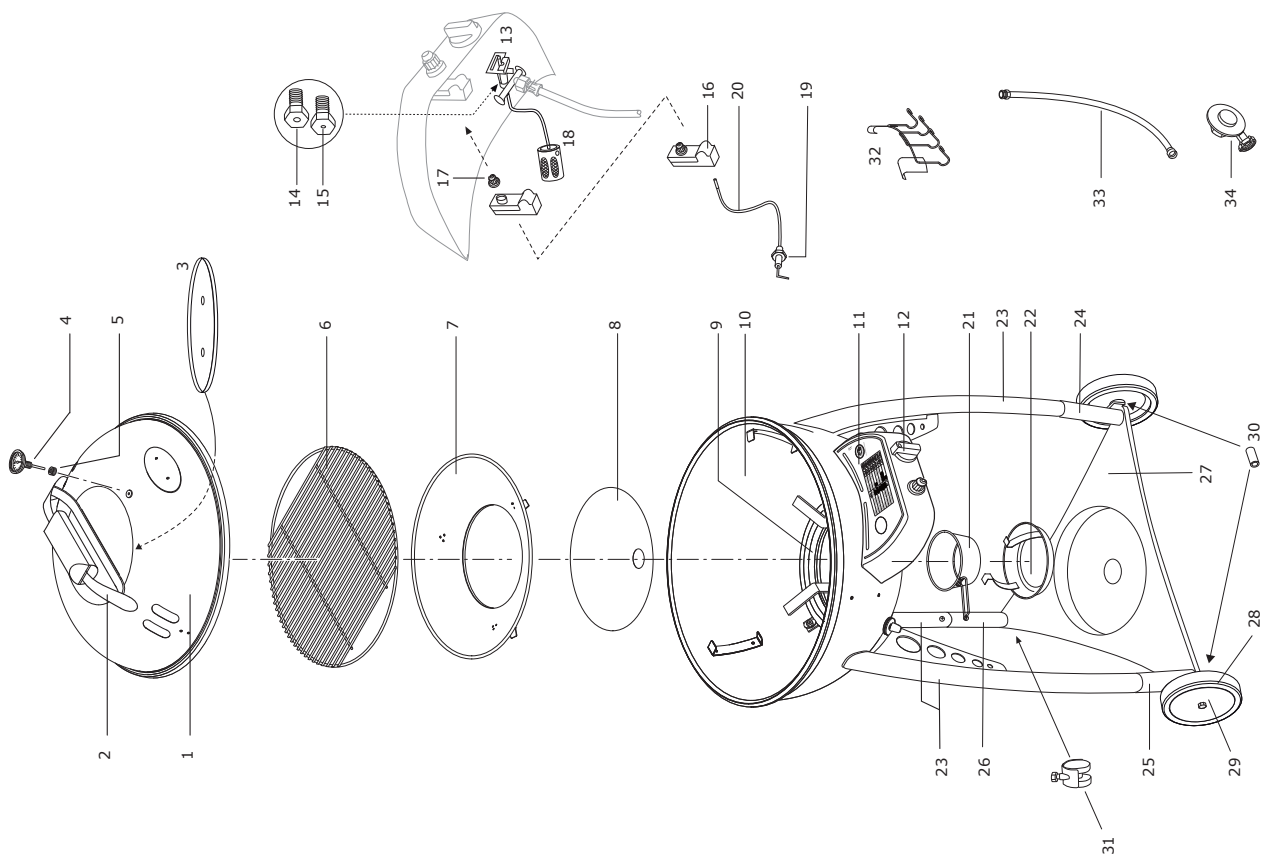

# Delta

Pos.	Art. Nr.	Description	Deckel
B		Lid	Beschreibung
B1	18.370.93	Protection washer lid handle	Schutz-Unterlagscheibe Deckelgriff
B2	18.370.76	Teflonwasher	U-Scheibe Teflon
B3	18.370.62	Washer	U-Scheibe
B4	18.370.43	Nut	Mutter

Pos.	Art. Nr.	Description	Ventilsatz & Konsole
D		Valve assembly & Panel	Beschreibung
D1	18.370.05	Screw	Schraube
D2	18.371.01	Screw	Schraube
D3	18.371.02	Washer	U-Scheibe
D4	18.371.03	Teflonwasher	U-Scheibe Teflon
D5	18.370.86	Teflonwasher	U-Scheibe Teflon
D6	18.371.00	Screw	Schraube

Pos.	Art. Nr.	Description	Bowl
E		Bowl	Kugel
E1	18.370.09	Screw	Beschreibung
E2	18.370.70	Protection washer bowl	Schraube
E3	18.370.76	Teflonwasher	Schutz-Unterlagscheibe Kugel
E4	18.370.62	Washer	U-Scheibe Teflon
E5	18.370.43	Nut	U-Scheibe
			Mutter

Pos.	Art. Nr.	Description	Piezo electrode
F		Piezo electrode	Beschreibung
F1	18.371.01	Screw	Schraube
F2	18.371.02	Washer	U-Scheibe
F3	18.371.03	Teflonwasher	U-Scheibe Teflon
F4	18.371.04	Spring washer	Federring
F5	18.370.48	Nut	Mutter
F6	18.371.11	Holder piezo electrode	Halterung Piezo Elektrode

# Delta



THE BARBECUE COMPANY

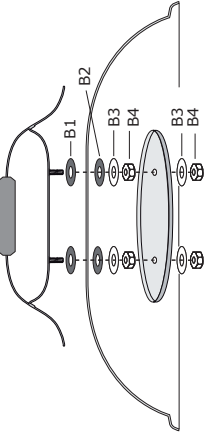

**B**

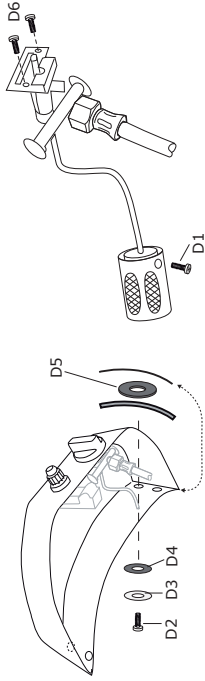
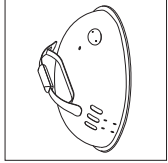

**D**

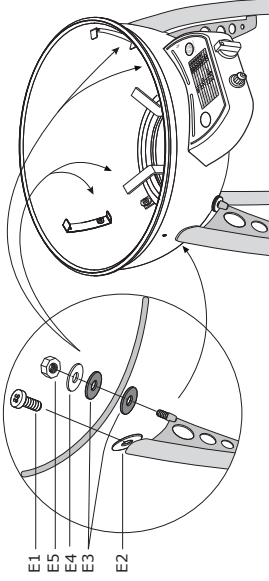
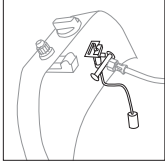

**E**

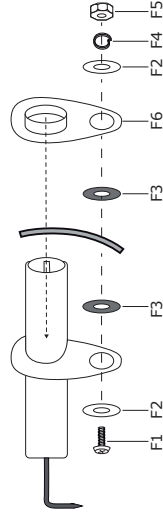
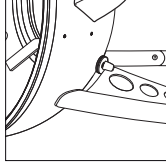

**F**

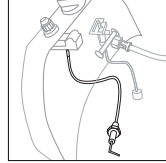

THE BARBECUE COMPANY



# Geneva

## Spare Parts

Pos. Art. Nr.	Description	Beschreibung
1	18.350.74 Lid black 570 LH 135°	Deckel schwarz 570 LH 135°
2	18.323.34 Lid handle Geneva	Deckelgriff Geneva
3	18.322.21 Lid hinge titan-silver complete	Deckelscharnier titan-silber Komplett
4	18.360.31 Upper lid hinge cover	Deckelscharnier-Abdeckung oben
5	18.360.32 Lower lid hinge cover	Deckelscharnier-Abdeckung unten
6	18.850.13 Heat indicator °C/°F	Temperatur Anzeige °C/°F
7	18.850.14 Frame for heat indicator	Rahmen zu Temperaturanzeiger
8	18.850.12 Heat indicator-Nut	Temperaturanzeiger-Befestigungsmutter
9	18.320.00 Cooking grid	Grillrost
10	18.320.02 Large Funnel	Grosser Trichter
11	18.320.03 Small Funnel	Kleiner Trichter
12	18.350.75 Bowl black 570 Geneva	Kugel schwarz 570 Geneva
13	18.614.06 Control knob big	Gasregulier-Knopf gross
14	18.614.07 Frame for control knob big	Rahmen zu Gasregulier-Knopf gross
15	18.614.08 Control knob small	Gasregulier-Knopf klein
16	18.614.09 Frame for control knob small	Rahmen zu Gasregulier-Knopf klein
17	18.323.33 Control panel DB Geneva	Bedienungskonsole DB Geneva
18	18.340.62 Valve assembly Geneva	Ventilsatz Geneva
19	18.340.14 Injector small burner 30mbar BF	Düse für kleiner Brenner 30mbar BF
20	18.340.13 Injector small burner 50mbar AF	Düse für kleiner Brenner 50mbar AF
21	18.340.18 Injector large burner 30mbar BT	Düse für grossen Brenner 30mbar BT
22	18.340.17 Injector large burner 50mbar AT	Düse für grossen Brenner 50mbar AT
23	18.340.58 Venturiprotection DB small	Venturischutz DB klein
24	18.340.57 Venturiprotection DB & SB	Venturischutz DB & SB
25	18.340.63 Pulse ignitor DB Geneva	Elektro-Zündung DB Geneva
26	18.340.02 Burner small 30mbar	Brenner klein 30mbar
26	18.340.45 Burner small 50mbar	Brenner klein 50mbar
27	18.340.00 Burner large 30mbar	Grosser Brenner 30mbar
27	18.340.44 Burner large 50mbar	Grosser Brenner 50mbar
28	18.340.12 Ignition wire	Zündungskabel
29	18.340.64 Ignition wire distributor	Zündungskabel Verteiler
30	18.340.11 Piezo electrode large burner	Piezo-Elektrode grosser Brenner
31	18.340.10 Piezo electrode small burner	Piezo-Elektrode kleiner Brenner
32	18.323.04 Drip pan	Fettauffangschale
33	18.323.05 Drip pan carrier	Fettauffangschale Halterung
34	18.323.36 Stainless steel column	Edelstahlsäule
35	18.323.37 Bottom plate	Bodenplatte
36	18.360.51 Caster with brake	Lenkrolle mit Bremse
37	18.360.50 Caster without brake	Lenkrolle ohne Bremse
38	18.360.52 Protective ring gas hose opening	Schutzring Gasschlauchöffnung
39	18.323.38 Sidecarrier left front & right back	Seitentablarhalterung vo.li & hi. re.
40	18.323.39 Sidecarrier right front & left back	Seitentablarhalterung vo.re & hi. li.
41	18.323.42 Brace carrier	Halterungsstrebe li & re
42	18.323.40 Side table right & left	Seitentablar rechts und links
43	18.323.35 Gas hose Hook	Gasschlauch-Haken
44	18.379.15 Hardware Set	Schrauben Set
44	individual Gas hose	Gasschlauch
45	individual Gas regulator	Gasdruckregler

### Attention

Please write your serial number on the backside of the manual for future reference. You will find the number on the data plate attached to the trolley or the bottom plate depending on the grill model. OUTDOORCHEF can only supply spare parts and honour warranty returns when the serial number is available.

### Achtung

Bitte notieren Sie auf der Rückseite Ihrer Gebrauchsanweisung die Serien-Nummer. Je nach Grillmodell finden Sie die Nummer auf dem Datensticker, welcher sich entweder am Grillgestell oder auf der Bodenplatte befindet. OUTDOORCHEF kann Garantie und Ersatzteil-lieferungen nur mit der Serien-Nummer bearbeiten.

# Geneva



THE BARBECUE COMPANY

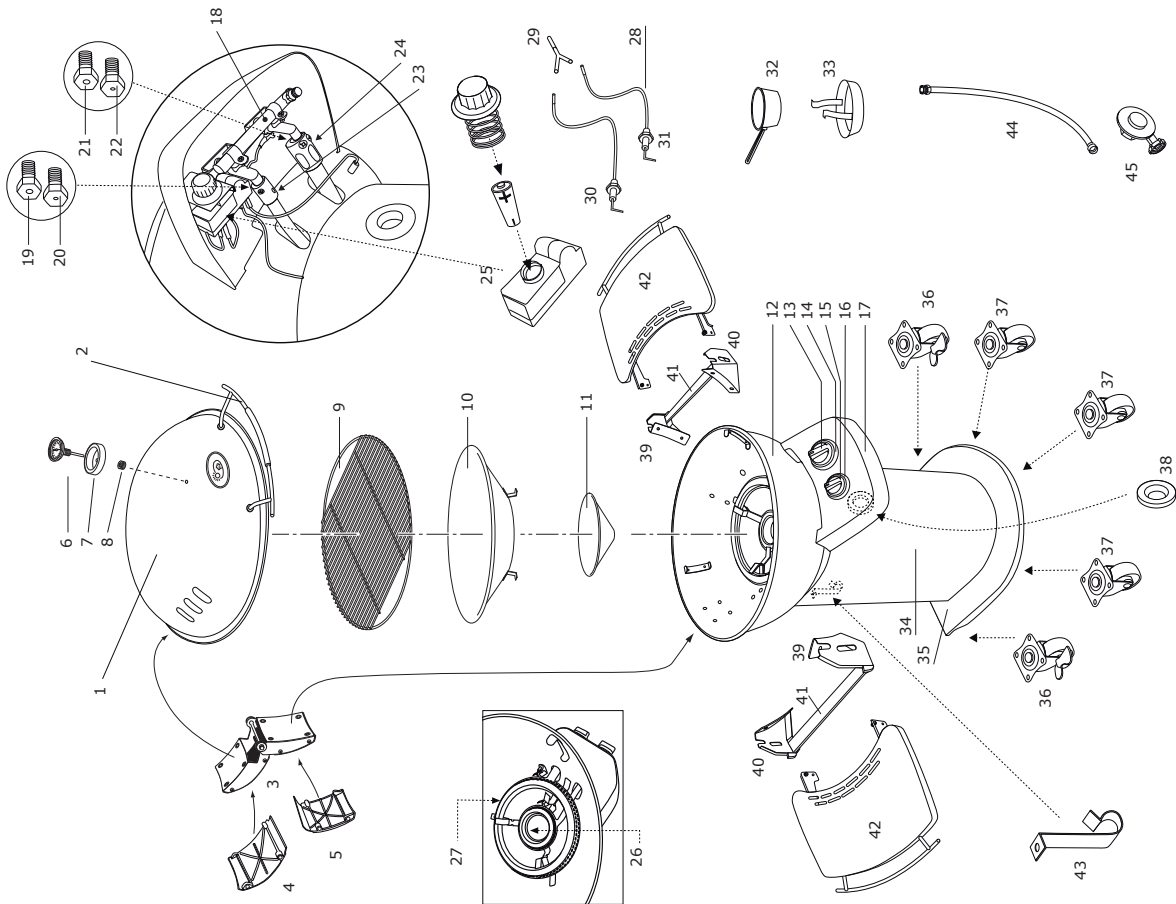

# Geneva

B	Lid	Deckel
Pos.	Art. Nr.	Description
B1	18.371.16	Washer
B2	18.371.17	Teflonwasher
B3	18.371.18	Nut

C	Lid Hinge	Deckelscharnier
Pos.	Art. Nr.	Description
C1	18.332.27	Lid hinge axle
C2	18.370.40	Dome Nut
C3	18.370.63	Washer
C4	18.371.19	Teflonwasher
C5	18.370.28	Lid hinge cover screw

D	Valve assembly & Panel	Ventilsatz & Konsole
Pos.	Art. Nr.	Description
D1	18.370.05	Screw
D2	18.371.01	Screw
D3	18.371.02	Washer
D4	18.371.03	Teflonwasher
D5	18.370.86	Teflonwasher
D6	18.371.00	Screw

E	Bowl	Kugel
Pos.	Art. Nr.	Description
E1	18.370.10	Screw
E2	18.370.62	Washer
E3	18.370.76	Teflonwasher
E4	18.370.91	Protection washer bowl
E5	18.370.68	Washer
E6	18.371.19	Dome nut

F	Piezo electrode	Piezo-Elektrode
Pos.	Art. Nr.	Description
F1	18.371.01	Screw
F2	18.371.02	Washer
F3	18.371.03	Teflonwasher
F4	18.371.04	Spring washer
F5	18.370.48	Nut
F6	18.371.11	Holder piezo electrode

# Geneva

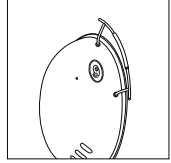

B

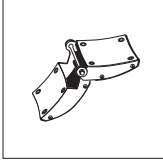

C

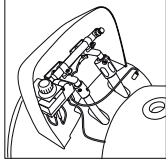

D

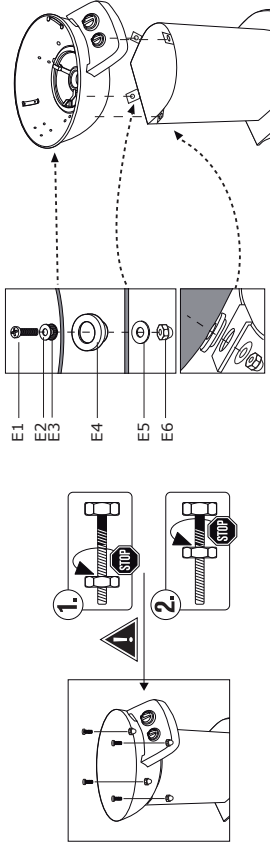

E

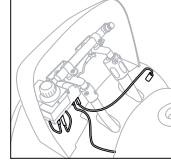

F

Pos. Art. Nr.	Description	Beschreibung
1 18.350.49	Lid black 570 LH	Deckel schwarz 570 LH
1 18.350.53	Lid vanilla 570 LH	Deckel vanille 570 LH
2 18.322.73	Lid handle titan-silver	Deckelgriff titan-silber
2 18.322.72	Lid handle black	Deckelgriff schwarz
3 18.323.00	Heat Shield	Hitzeschild
4 18.322.21	Lid hinge titan-silver complete	Deckelscharnier titan-silber Komplett
4 18.322.22	Lid hinge black complete	Deckelscharnier schwarz Komplett
5 18.360.31	Upper lid hinge cover	Deckelscharnier-Abdeckung oben
6 18.360.32	Lower lid hinge cover	Deckelscharnier-Abdeckung unten
7 18.850.13	Heat indicator °C/°F	Temperatur Anzeige °C/°F
8 18.850.14	Frame for heat indicator	Rahmen zu Temperaturanzeiger
9 18.850.12	Heat indicator-Nut	Temperaturanzeiger-Befestigungsmutter
10 18.320.00	Cooking grid	Grillrost
11 18.320.02	Large Funnel	Grosser Trichter
12 18.320.03	Small Funnel	Kleiner Trichter
13 18.350.16	Bowl black LH SB Ph	Kugel schwarz LH SB Ph
13 18.350.42	Bowl vanilla LH SB Ph	Kugel vanille LH SB Ph
14 18.360.20	Control knob	Gasregulier-Knopf
15 18.322.57	Control panel SB titan-silver	Bedienkonsole SB titan-silber
15 18.322.56	Control panel SB black	Bedienkonsole SB schwarz
16 18.340.48	Valve assembly with bundy	Ventilsatz mit bundy
17 18.340.18	Injector large burner 30mbar mark: BT	Düse für grossen Brenner 30mbar mark: BT
18 18.340.17	Injector large burner 50mbar mark: AT	Düse für grossen Brenner 50mbar mark: AT
19 18.340.07	Pulse ignitor SB complete	Druckknopf Zündung
20 18.360.21	Push button ignitor	Venturischutz
21 18.340.57	Venturiprotection	Grosser Brenner 30mbar
22 18.340.00	Burner large 30mbar	Grosser Brenner 50mbar
22 18.340.44	Burner large 50mbar	Zündungskabel
23 18.340.12	Ignition wire	Piezo- Elektrode grosser Brenner
24 18.340.11	Piezo electrode large burner	Fettauffangschale
25 18.323.04	Drip pan	Fettauffangschale Halterung
26 18.323.05	Drip pan carrier	Bein hinten rechts titan-silber
27 18.322.58	Leg rear right titan-silver	Bein hinten rechts schwarz
27 18.322.59	Leg rear right black	Bein hinten links titan-silber
28 18.322.60	Leg rear left titan-silver	Bein hinten links schwarz
28 18.322.61	Leg rear left black	Bein vorne rechts titan-silber
29 18.322.62	Leg front right titan-silver	Bein vorne rechts schwarz
29 18.322.63	Leg front right black	Bein vorne links titan-silber
30 18.322.64	Leg front left titan-silver	Bein vorne links schwarz
30 18.322.65	Leg front left black	Abschlusskappe
31 18.870.05	End Cap	Träger titan-silber
32 18.322.66	Supporter titan-silver	Träger schwarz
32 18.322.67	Supporter black	Radachse titan-silber
33 18.322.92	Axle titan-silver	Radachse schwarz
33 18.322.93	Axle black	Fixierachse titan-silber
34 18.322.70	Fixation bar titan-silver	Fixierachse schwarz
34 18.322.71	Fixation bar black	Bodenplatte schwarz
35 18.321.90	Bottom plate black	Rad
36 18.360.38	Wheel	Radabdeckung titan-silber
37 18.360.39	Wheel cover titan-silver	Radabdeckung schwarz
37 18.360.49	Wheel cover black	Laufbuche
38 18.360.44	Liner wheel	Faschenhalterungs-Gurt
39 18.360.11	Bottle fixation strap	Schrauben Set
39 18.378.87	Hardware Set	Besteck-Halter
40 18.320.20	Tool holder	Gas Schlauch
41 individual	Gas hose	Gasdruckregler
42 individual	Gas regulator	

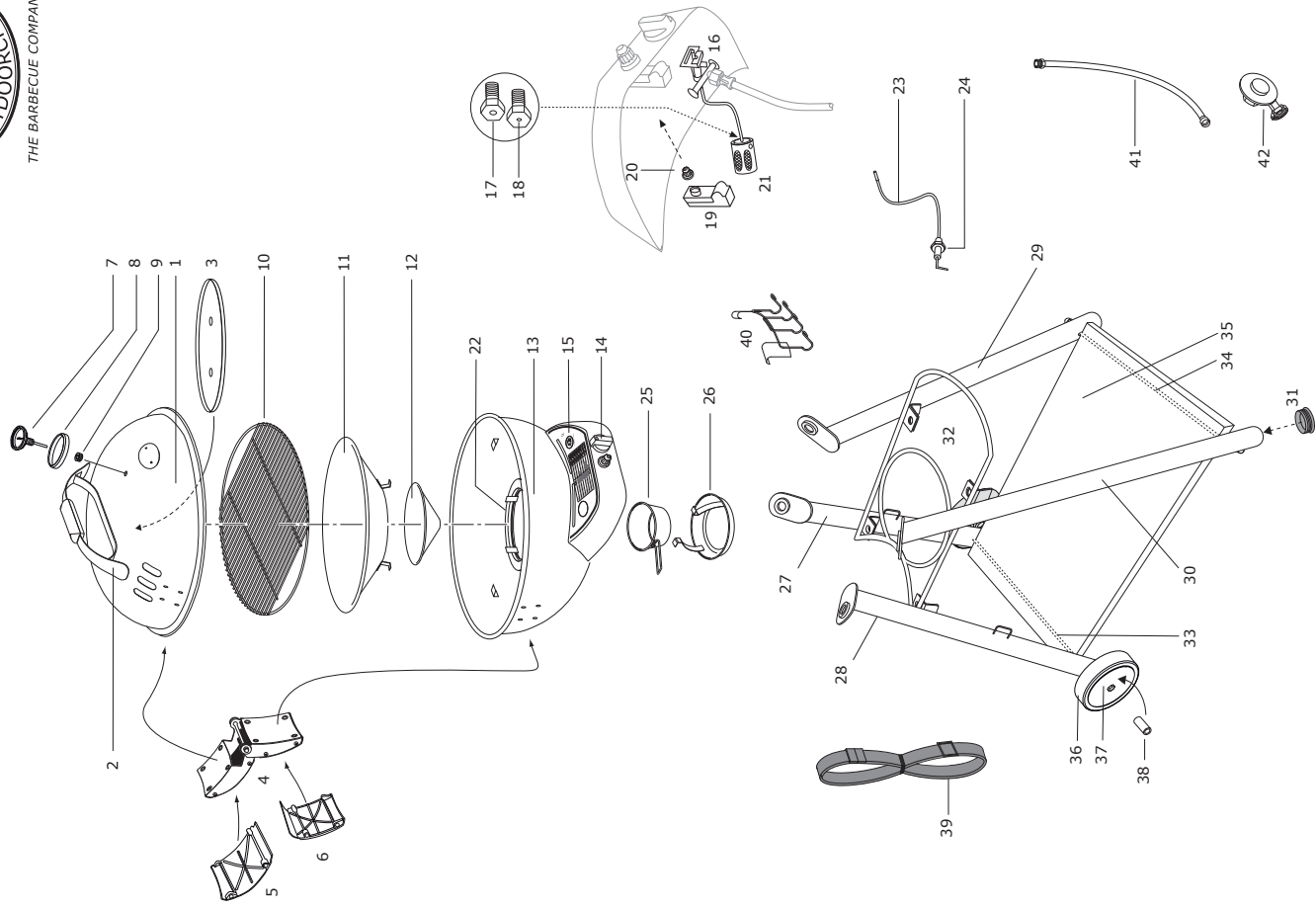

B	Art. Nr.	Description	Deckel
B1	18.370.90	Protection washer lid handle	Schutz-Untertagscheibe Deckelgriff
B2	18.370.76	Teflonwasher	U-Scheibe Teflon
B3	18.370.62	Washer	U-Scheibe
B4	18.370.43	Nut	Mutter

C	Art. Nr.	Description	Deckelscharnier
C1	18.332.27	Lid hinge axle	Deckelscharnierachse
C2	18.370.40	Dome Nut	Hutmutter
C3	18.370.63	Washer	U-Scheibe
C4	18.370.76	Teflonwasher	U-Scheibe Teflon
C5	18.370.28	Lid hinge cover screw	Deckelscharnier-Abdeckungsschrauben

D	Art. Nr.	Description	Ventilsatz & Konsole
D1	18.370.05	Screw	Schraube
D2	18.371.01	Screw	Schraube
D3	18.371.02	Washer	U-Scheibe
D4	18.371.03	Teflonwasher	U-Scheibe Teflon
D5	18.370.86	Teflonwasher	U-Scheibe Teflon
D6	18.371.00	Screw	Schraube

E	Art. Nr.	Description	Bowl
E1	18.370.10	Screw	Schraube
E2	18.370.62	Washer	U-Scheibe
E3	18.370.76	Teflonwasher	U-Scheibe Teflon
E4	18.370.89	Washer Alu.	U-Scheibe Alu.
E5	18.370.68	Washer	U-Scheibe
E6	18.370.44	Wing nut	Flügelmutter

F	Art. Nr.	Description	Piezo-Elektrode
F1	18.371.01	Screw	Schraube
F2	18.371.02	Washer	U-Scheibe
F3	18.371.03	Teflonwasher	U-Scheibe Teflon
F4	18.371.04	Spring washer	Federring
F5	18.370.48	Nut	Mutter
F6	18.371.11	Holder piezo electrode	Halterung Piezo Elektrode

### Attention

Please write your serial number on the backside of the manual for future reference. You will find the number on the data plate attached to the trolley or the bottom plate depending on the grill model. OUTDOORCHEF can only supply spare parts and honour warranty returns when the serial number is available.

### Achtung

Bitte notieren Sie auf der Rückseite Ihrer Gebrauchsanweisung die Serien-Nummer. Je nach Grillmodell finden Sie die Nummer auf dem Datensticker, welcher sich entweder am Grillgestell oder auf der Bodenplatte befindet. OUTDOORCHEF kann Garantie und Ersatzteil-lieferungen nur mit der Serien-Nummer bearbeiten.

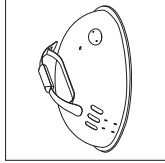
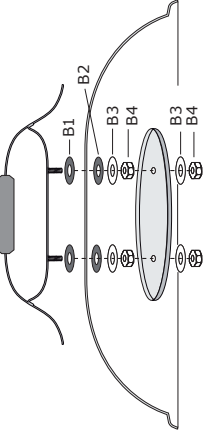

**B**

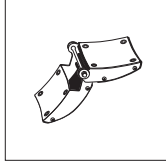
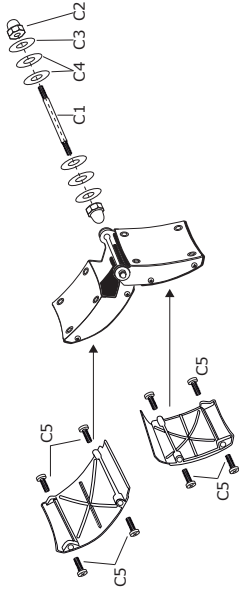

**C**

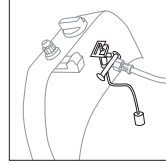
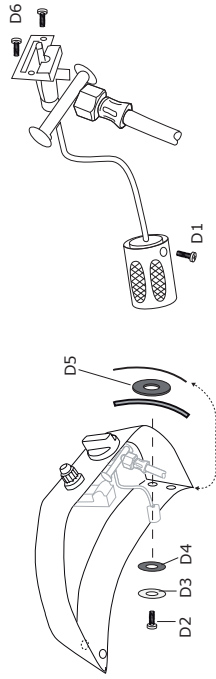

**D**

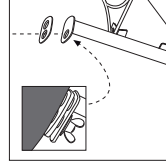
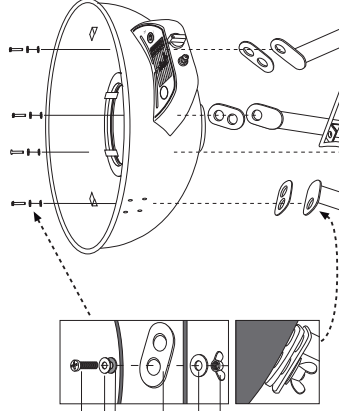

**E**

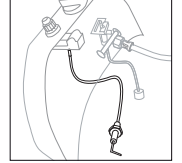
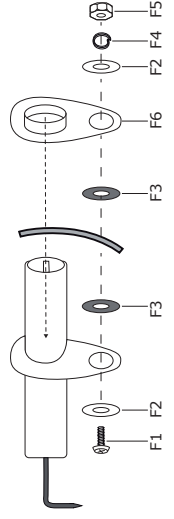

**F**



# Montreux

## Spare Parts

Pos. Art. Nr.	Description	Beschreibung
1	18.350.49	Lid black 570 LH
2	18.322.73	Lid handle titan-silver
3	18.323.00	Heat Shield
4	18.322.21	Lid hinge titan-silver complete
5	18.360.31	Upper lid hinge cover
6	18.360.32	Lower lid hinge cover
7	18.850.13	Heat indicator °C/°F
8	18.850.14	Frame for heat indicator
9	18.850.12	Heat indicator-Nut
10	18.320.00	Cooking grid
11	18.320.02	Large Funnel
12	18.320.03	Small Funnel
13	18.350.14	Bowl LH DB Pt schwarz
14	18.360.20	Control knob
15	18.322.04	Control panel DB titan-silver
16	18.340.50	Valve assembly direct DB
17	18.340.14	Injector small burner 30mbar BF
18	18.340.13	Injector small burner 50mbar AF
19	18.340.18	Injector large burner 30mbar BT
20	18.340.17	Injector large burner 50mbar AT
21	18.340.58	Venturiprotection DB small
22	18.340.57	Venturiprotection DB & SB
23	18.340.08	Pulse ignitor DB complete
24	18.360.21	Push button ignitor
25	18.340.02	Burner small 30mbar
25	18.340.45	Burner small 50mbar
26	18.340.00	Burner large 30mbar
26	18.340.44	Burner large 50mbar
27	18.340.12	Ignition wire
28	18.340.11	Piezo electrode large burner
29	18.340.10	Piezo electrode small burner
30	18.323.04	Drip pan
31	18.323.05	Fettauffangschale Halterung
32	18.322.05	X-Modul titan-silver
33	18.322.99	Stand-Module titan-silver
34	18.322.40	Table-Module titan-silver
35	18.322.08	Wheel-Module left titan-silver
36	18.322.09	Wheel-Module right titan-silver
37	18.323.11	Axle titan-silver
38	18.322.12	Bottle fixation bar titan-silver
39	18.360.11	Bottle fixation strap
40	18.310.20	Bottom shelf black wood
41	18.380.08	Side table granite stone
42	18.360.05	Wheel
43	18.360.40	Wheel cover
44	18.360.45	Liner wheel
45	18.360.37	Height adjustment
46	18.320.21	Tool holder
47	18.321.10	Gas hose Hook
48	18.378.88	Hardware Set
49	individual	Gas hose
49	individual	Gas regulator

### Attention

Please write your serial number on the backside of the manual for future reference. You will find the number on the data plate attached to the trolley or the bottom plate depending on the grill model. OUTDOORCHEF can only supply spare parts and honour warranty returns when the serial number is available.

### Achtung

Bitte notieren Sie auf der Rückseite Ihrer Gebrauchsanweisung die Serien-Nummer. Je nach Grillmodell finden Sie die Nummer auf dem Datensticker, welcher sich entweder am Grillgestell oder auf der Bodenplatte befindet. OUTDOORCHEF kann Garantie und Ersatzteil-lieferungen nur mit der Serien-Nummer bearbeiten.

# Montreux



THE BARBECUE COMPANY

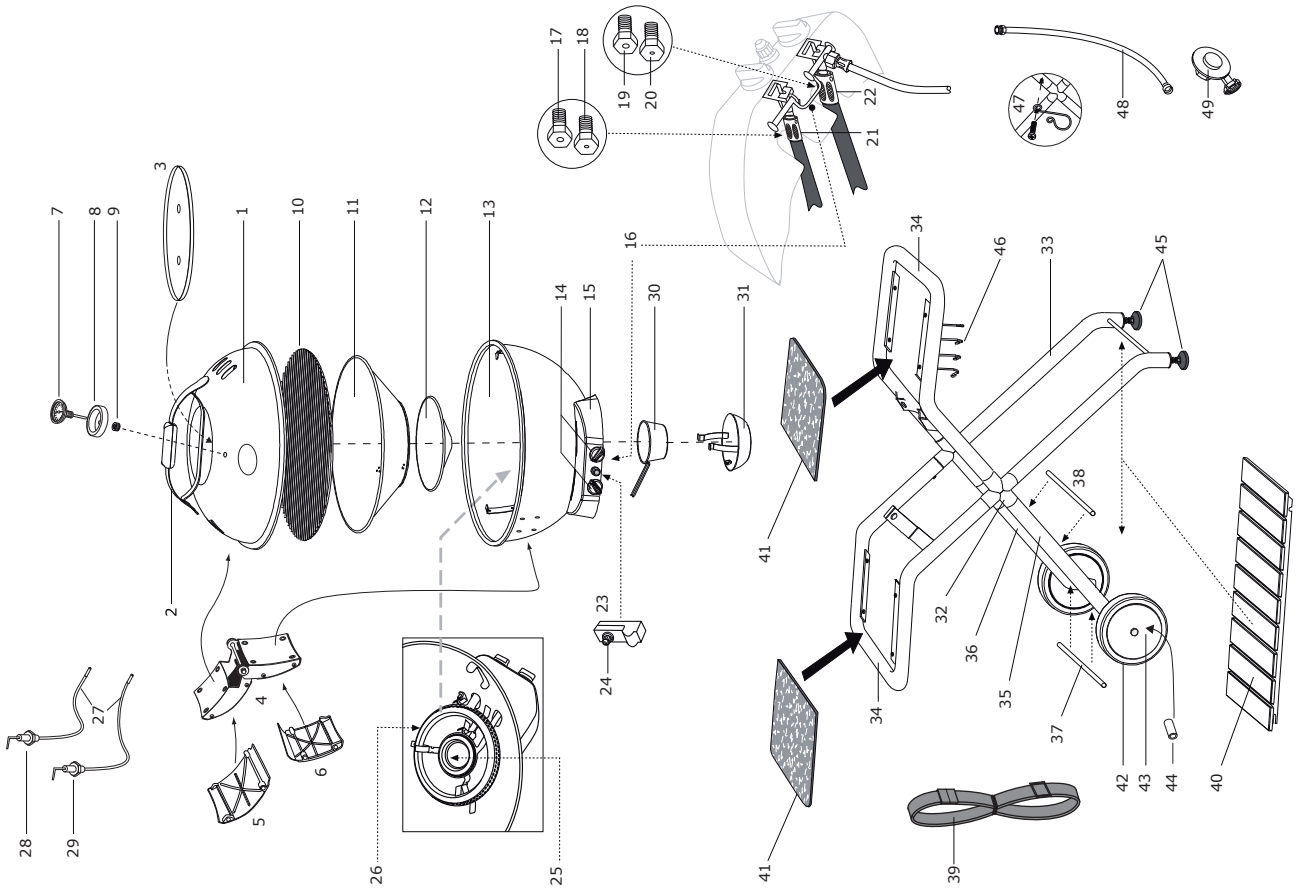

# Montreux

B	Lid
Pos.	Description
B1	18.370.90 Protection washer lid handle
B2	18.370.76 Teflonwasher
B3	18.370.62 U-Scheibe
B4	18.370.43 Nut

C	Lid Hinge
Pos.	Description
C1	18.332.27 Lid hinge axle
C2	18.370.40 Dome Nut
C3	18.370.63 Washer
C4	18.370.76 Teflonwasher
C5	18.370.28 Lid hinge cover screw

D	Valve assembly & Panel
Pos.	Description
D1	18.370.05 Screw
D2	18.371.01 Screw
D3	18.371.02 Washer
D4	18.371.03 Teflonwasher
D5	18.370.86 Teflonwasher
D6	18.371.00 Screw

E	Bowl
Pos.	Description
E1	18.370.10 Screw
E2	18.370.62 Washer
E3	18.370.76 Teflonwasher
E4	18.370.91 Protection washer bowl
E5	18.370.68 Washer
E6	18.370.44 Wing nut

F	Piezo electrode
Pos.	Description
F1	18.371.01 Screw
F2	18.371.02 Washer
F3	18.371.03 Teflonwasher
F4	18.371.04 Spring washer
F5	18.370.48 Nut
F6	18.371.11 Holder piezo electrode

G	Side Tablar & Bottom shelf
Pos.	Description
G1	18.371.05 Woodscrew



European Outdoor Chef operates a policy of continuous product development and improvement. As such we reserve the right to alter product design and or technical specification without giving any prior notice.

# Montreux



THE BARBECUE COMPANY

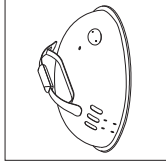

B

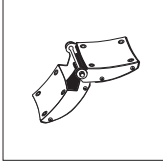

C

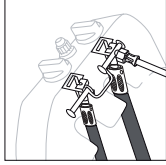

D

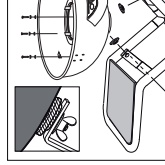

E

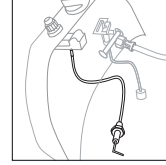

F

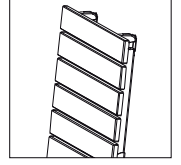

G

# Munich

## Spare Parts

Pos.	Art. Nr.	Description	Beschreibung
1	18.350.59	Lid onyx	Deckel onyx
2	18.322.95	Lid handle titan-silver	Deckelgriff titan-silber
3	18.323.00	Heat Shield	Hitzeschild
4	18.320.63	Lid hinge	Deckelscharnier
5	18.850.13	Heat indicator °C/°F	Temperatur Anzeige °C/°F
6	18.850.14	Frame for heat indicator	Rahmen zu Temperaturanzeiger
7	18.850.12	Heat indicator-Nut	Temperaturanzeiger-Befestigungsmutter
8	18.320.01	Cooking grid	Grillrost
9	18.320.04	Large funnel	Grosser Trichter
10	18.320.03	Small funnel	Kleiner Trichter
11	18.350.48	Bowl onyx	Kugel onyx
12	18.614.04	Control knob	Gasregulier-Knopf
13	18.614.05	Frame for control knob	Rahmen zu Gasregulier-Knopf
14	18.322.96	Control panel SB titan-silver	Bedienkonsole SB titan-silber
15	18.340.53	Valve assembly Kettle Grill	Ventilsatz Kugelgrill
16	18.340.16	Injector 30mbar mark: BN	Düse 30mbar mark: BN
17	18.340.15	Injector 50mbar mark: AN	Düse 50mbar mark: AN
18	18.340.57	Venturiprotection DB & SB	Venturischutz DB & SB
19	18.340.07	Pulse ignitor SB complete	Elektro Zündung SB Komplett
20	18.360.21	Push button ignitor	Druckknopf Zündung
21	18.340.01	Burner	Brenner
22	18.340.09	Piezo electrode	Piezo Elektrode
23	18.340.12	Ignition wire	Zündungskable
24	18.323.04	Drip pan	Fettauffangschale
25	18.323.05	Drip pan carrier	Fettauffangschale Halterung
26	18.380.20	Granit stone	Granit Platte
27	18.322.97	Side table frame titan-silver	Seitentablar-Rahmen titan-silber
28	18.322.87	Front panel side table titan-silver	Frontblende Seitentablar titan-silber
29	18.322.98	Bowl frame titan-silver	Kugelrahmen titan-silber
30	18.322.48	Leg titan-silver	Bein titan-silber
31	18.323.01	Lower frame titan-silver	Unterer Rahmen titan-silber
32	18.360.34	Puffer	Puffer
33	18.322.29	Bottle jacket black	Flaschenschale schwarz
34	18.323.02	Bottom shelf black	Bodenplatte schwarz
35	18.323.03	Tool holder	Besteckhalterung
36	18.360.27	Caster with brake	Rad mit Bremse
18.379.06	Hardware-Set	Schrauben-Set	Schrauben-Set
37	individual	Gas hose	Gasschlauch
38	individual	Gas regulator	Gasdruckregler

### Attention

Please write your serial number on the backside of the manual for future reference. You will find the number on the data plate attached to the trolley or the bottom plate depending on the grill model. OUTDOORCHEF can only supply spare parts and honour warranty returns when the serial number is available.

### Achtung

Bitte notieren Sie auf der Rückseite Ihrer Gebrauchsanweisung die Serien-Nummer. Je nach Grillmodell finden Sie die Nummer auf dem Datensticker, welcher sich entweder am Grillgestell oder auf der Bodenplatte befindet. OUTDOORCHEF kann Garantie und Ersatzteil-lieferungen nur mit der Serien-Nummer bearbeiten.



European Outdoor Chef operates a policy of continuous product development and improvement. As such we reserve the right to alter product design and or technical specification without giving any prior notice.

# Munich

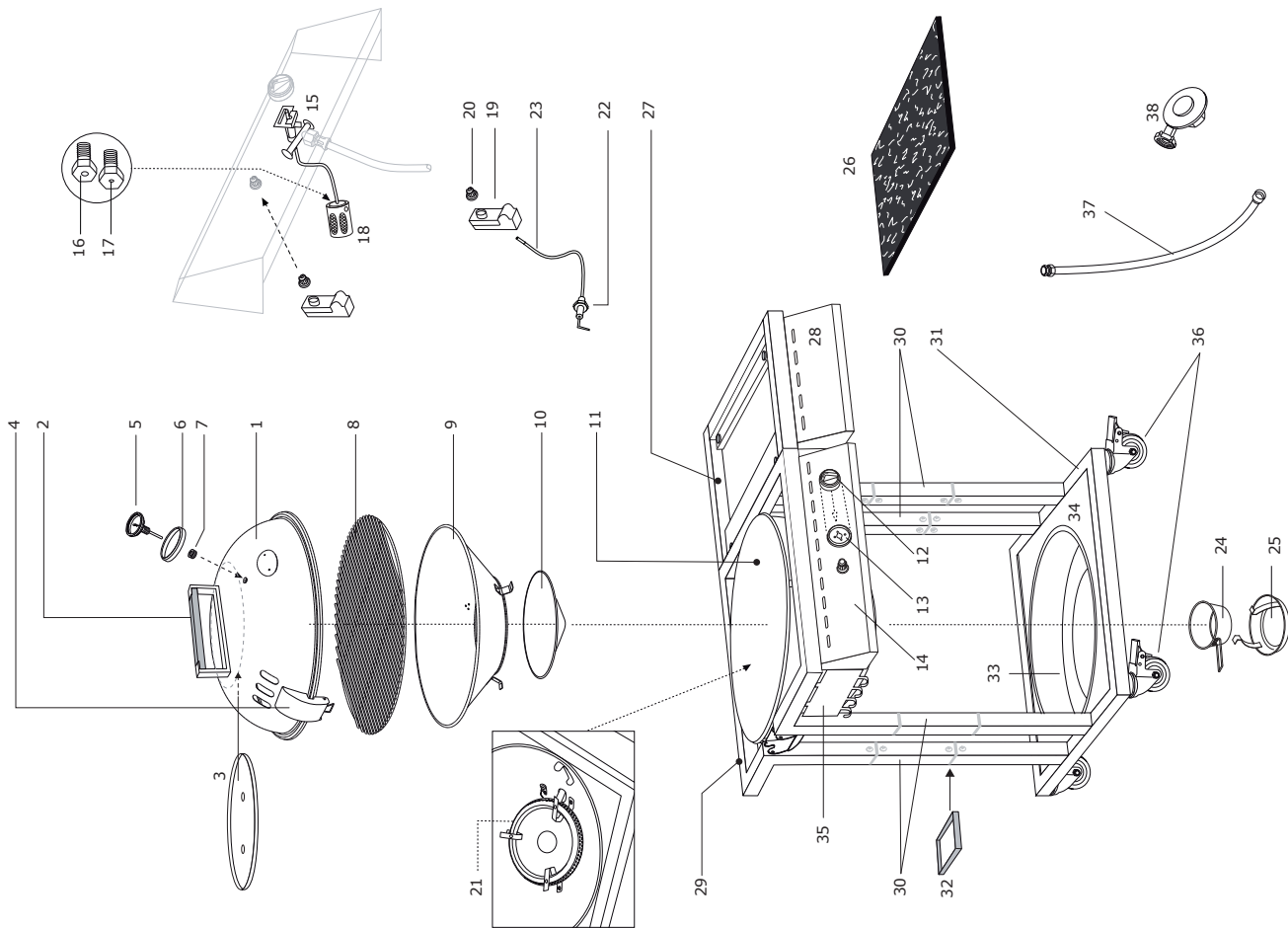

# Munich

B	Lid	Deckel
Pos.	Art. Nr.	Beschreibung
B1	18.370.86	Protection washer lid handle
B2	18.370.76	Teflonwasher
B3	18.370.62	Washer
B4	18.370.39	Twin screw Lid handle
B5	18.370.43	Nut

D	Valve assembly & Panel	Ventilsatz & Konsole
Pos.	Art. Nr.	Beschreibung
D1	18.370.05	Screw
D2	18.371.00	Schraube

F	Piezo electrode	Piezo-Elektrode
Pos.	Art. Nr.	Beschreibung
F1	18.371.01	Screw
F2	18.371.02	Washer
F3	18.371.03	Teflonwasher
F4	18.371.04	Spring washer
F5	18.370.48	Nut
F6	18.371.11	Holder piezo electrode

# Munich

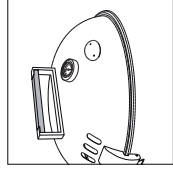

**B**

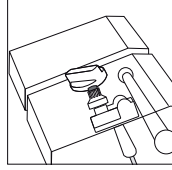
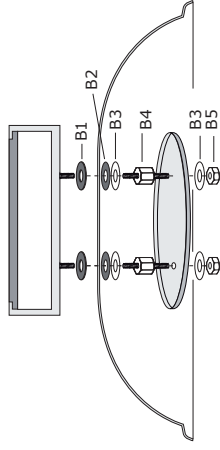

**D**

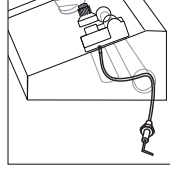
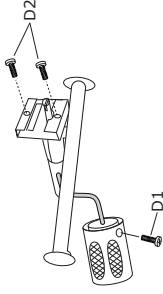

**F**

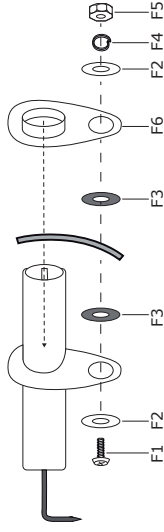



# Paris Deluxe

## Spare Parts

Pos.	Art. Nr.	Description	Beschreibung
1	18.350.58	Lid 570 LH, onyx	Deckel 570 LH, onyx
2	18.322.35	Lid handle, titan-silver	Deckelgriff, titan-silber
3	18.323.00	Heat Shield	Hitzeschild
4	18.320.10	Lid Hinge	Deckelscharnier
5	18.850.13	Heat indicator °C/°F	Temperatur-Anzeige °C/°F
6	18.850.14	Frame for heat indicator	Rahmen zu Temperaturanzeiger
7	18.850.12	Heat indicator-Nut	Temperaturanzeiger-Befestigungsmutter
8	18.320.00	Cooking grid	Grillrost
9	18.320.02	Large Funnel	Grosser Trichter
10	18.320.03	Small Funnel	Kleiner Trichter
11	18.350.15	Bowl LH DB Pt, onyx	Kugel LH DB Pt, onyx
12	18.614.04	Control knob	Gasregulier-Knopf
13	18.614.05	Frame for control knob	Rahmen zu Gasregulier-Knopf
14	18.322.82	Control panel Kettle Grill titan-silver	Bedienkonsole Kugelgrill titan-silber
15	18.340.56	Valve assembly Kettle Grill	Ventilsatz Kugelgrill
16	18.340.58	Venturi-protection DB small	Venturischutz DB klein
17	18.340.57	Venturi-protection DB & SB	Venturischutz DB & SB
18	18.340.14	Injector small burner 30mbar mark: BF	Düse kleiner Brenner Kugelgrill 30mbar mark: BF
19	18.340.13	Injector large burner 50mbar mark: AF	Düse grosser Brenner Kugelgrill 50mbar mark: AF
20	18.340.18	Injector large burner 30mbar mark: BT	Düse grossen Brenner Kugelgrill 30mbar mark: BT
21	18.340.17	Injector large burner 50mbar mark: AT	Düse grossen Brenner Kugelgrill 50mbar mark: AT
22	18.340.08	Pulse ignitor DB complete	Elektro-Zündung DB Komplett
23	18.360.21	Push button ignitor	Druckknopf Zündung
24	18.340.02	Burner small 30mbar	Brenner klein 30mbar
25	18.340.45	Burner small 50mbar	Brenner klein 50mbar
26	18.340.00	Burner large 30mbar	Grosser Brenner 30mbar
27	18.340.44	Burner large 50mbar	Grosser Brenner 50mbar
28	18.340.12	Ignition wire	Zündungskabel
29	18.340.11	Piezo electrode large burner Kettle Grill	Piezo-Elektrode grosser Brenner Kugelgrill
30	18.340.10	Piezo electrode small burner Kettle Grill	Piezo-Elektrode kleiner Brenner Kugelgrill
31	18.322.83	Control panel side burner titan-silver	Bedienkonsole Seitenbrenner titan-silber
32	18.340.60	Side burner	Seitenbrenner
33	18.323.13	Side burner grate	Seitenbrenner Rost
34	18.340.51	Valve assembly side burner	Ventilsatz Seitenbrenner
35	18.340.25	Injector side burner 30mbar mark: BK	Düse Seitenbrenner 30mbar mark: BK
36	18.340.24	Injector side burner 50mbar mark: AG	Düse Seitenbrenner 50mbar mark: AG
37	18.340.37	Puls ignitorm SB, complete	Elektro-Zündung SB, Komplett
38	18.340.33	Piezo electrode side burner	Piezo-Elektrode Seitenbrenner
39	18.612.27	Connection Hose side burner	Verbindungsrohr Seitenbrenner
40	18.323.04	Drip Pan	Fettauffangschale
41	18.323.05	Drip Pan carrier	Fettauffangschale Halterung
42	18.380.16	Granit stone	Granit Platte
43	18.322.84	Side burner frame, titan-silver	Seitenbrenner-Rahmen, titan-silber
44	18.322.85	Bowl frame, titan-silver	Kugelrahmen, titan-silber
45	18.323.28	Side burner body	Seitenbrennergehäuse
46	18.322.48	Legs left, titan-silver	Beine links, titan-silber
47	18.322.53	Legs right, titan-silver	Beine rechts, titan-silber
48	18.323.32	Guidance bar	Plattenführung
49	18.322.36	Lower frame, titan-silver	Unterer Rahmen, titan-silber
50	18.360.34	Puffer	Puffer
51	18.322.29	Bottle jacket, black	Flaschenschale, schwarz
52	18.322.54	Bottom shelf, black	Bodenplatte, schwarz
53	18.322.94	Tool holder	Besteckhalterung
54	18.360.27	Caster with brake	Rad mit Bremse
55	18.379.05	Hardware-Set	Schrauben-Set
56	18.379.06	Gas hose	Gasschlauch
57	18.379.07	Gas regulator	Gasdruckregler

### Attention

Please write your serial number on the backside of the manual for future reference. You will find the number on the data plate attached to the trolley or the bottom plate, depending on the grill model. OUTDOORCHEF can only supply spare parts and honour warranty returns when the serial number is available.

# Paris Deluxe

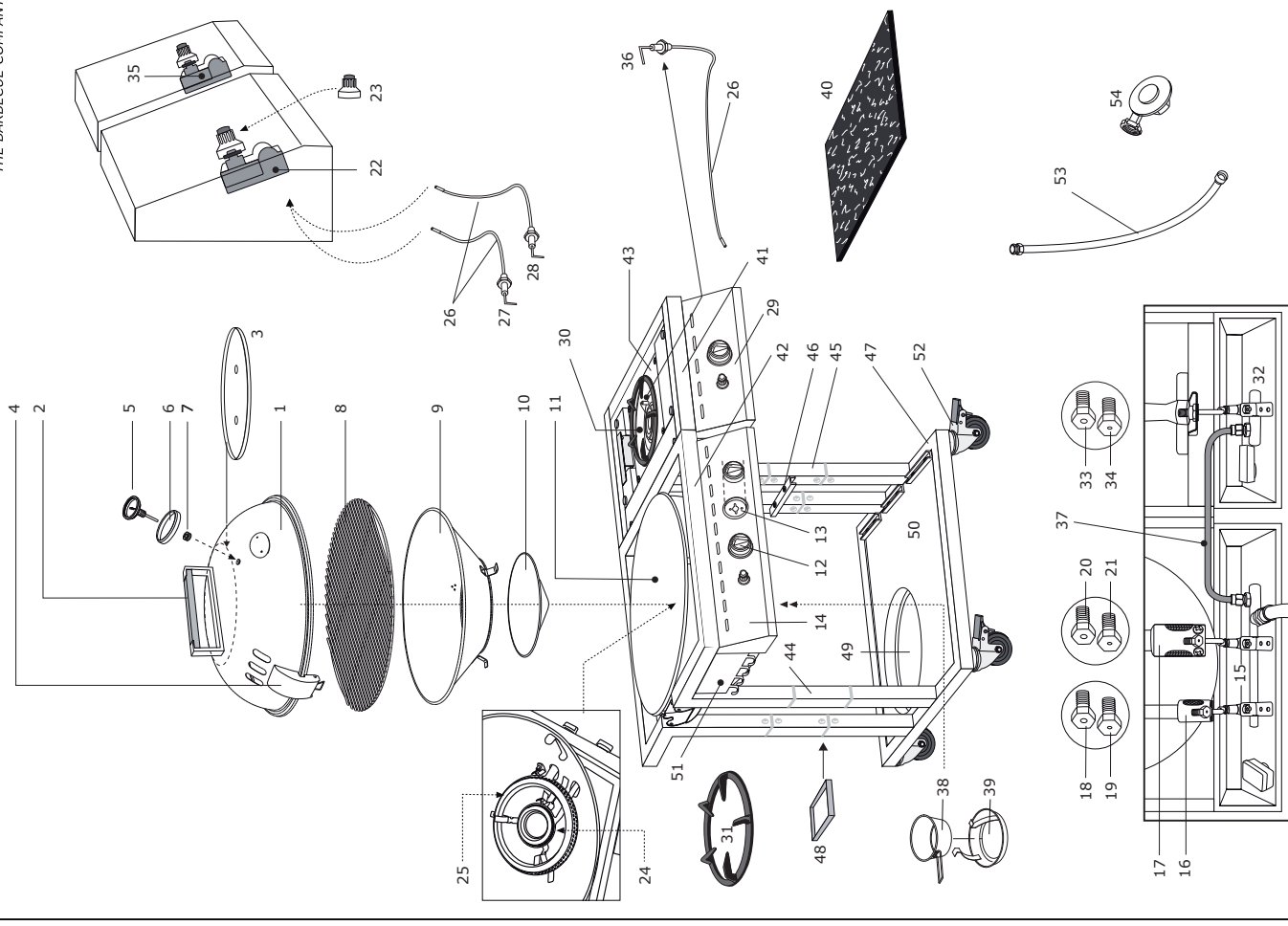

### Achtung

Bitte notieren Sie auf der Rückseite Ihrer Gebrauchsanweisung die Serien-Nummer. Je nach Grillmodell finden Sie die Nummer auf dem Datensticker, welcher sich entweder am Grillgestell oder auf der Bodenplatte befindet. OUTDOORCHEF kann Garantie und Ersatzteil-lieferungen nur mit der Serien-Nummer bearbeiten.

# Paris Deluxe

B	Lid	Deckel
Pos.	Art. Nr.	Beschreibung
B1	18.370.86	Protection washer lid handle
B2	18.370.76	Teflonwasher
B3	18.370.62	Washer
B4	18.370.39	Twin screw Lid handle
B5	18.370.43	Nut

D	Valve assembly & Panel	Ventilsatz & Konsole
Pos.	Art. Nr.	Beschreibung
D1	18.370.05	Screw
D2	18.371.00	Schraube

F	Piezo electrode	Piezo-Elektrode
Pos.	Art. Nr.	Beschreibung
F1	18.371.01	Screw
F2	18.371.02	Washer
F3	18.371.03	Teflonwasher
F4	18.371.04	Spring washer
F5	18.370.48	Nut
F6	18.371.11	Holder piezo electrode

# Paris Deluxe



THE BARBECUE COMPANY

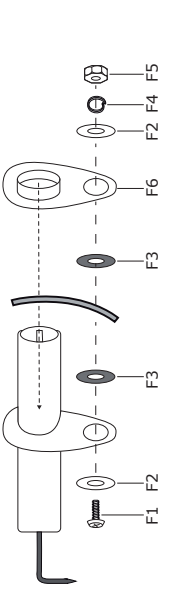
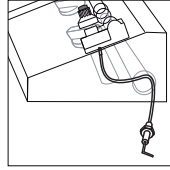
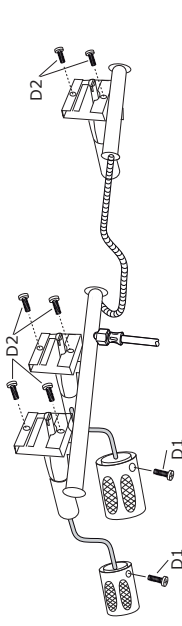
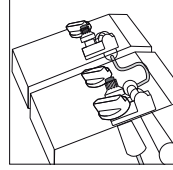
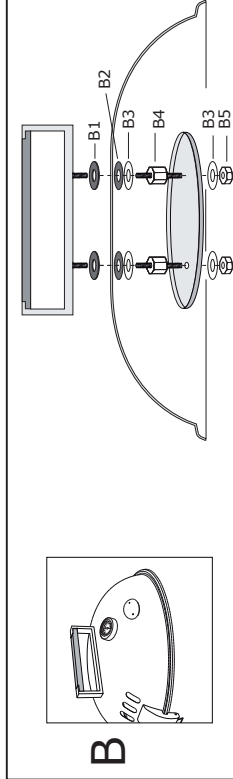

# Porto

## Spare Parts

Pos. Art. Nr.	Description	Beschreibung
1	18.350.55	Lid black
2	18.323.06	Lid handle EC style titan-silver
3	18.323.00	Heat Shield
4	18.850.13	Heat indicator °C/°F
5	18.850.12	Heat indicator-Nut
6	18.320.01	Grillrost
7	18.320.04	Large Funnel
8	18.320.03	Small Funnel
9	18.340.01	Burner
10	18.350.08	Bowl black
11	18.321.98	Control panel SB titan-silver
12	18.360.20	Control knob
13	18.340.47	Valve assembly SB with bundy
14	18.340.16	Injector 30mbar mark: BN
15	18.340.15	Injector 50mbar mark: AN
16	18.340.07	Pulse ignitor SB complete
17	18.360.21	Push bottom ignitor
18	18.340.57	Venturiprotection
19	18.340.09	Piezo electrode
20	18.340.12	Ignition wire
21	18.323.04	Drip pan
22	18.323.05	Drip pan carrier
23	18.322.74	Legs upper parts rear titan-silver
24	18.322.75	Leg upper part front titan-silver
25	18.322.76	Leg lower part front titan-silver
26	18.322.77	Leg lower part rear right titan-silver
27	18.322.78	Leg lower part rear left titan-silver
28	18.322.79	Half moon titan-silver
29	18.360.33	End Cap upper part
30	18.365.03	End Cap under part
31	18.323.08	Axle titan-silver
32	18.360.38	Wheel
33	18.360.39	Wheel cover
34	18.360.44	Liner wheel
35	18.322.81	Carry handle titan-silver
36	18.320.19	Tool holder
37	18.378.89	Hardware set
38	individual	Gas hose
	individual	Gas regulator

### Attention

Please write your serial number on the backside of the manual for future reference. You will find the number on the data plate attached to the trolley or the bottom plate depending on the grill model. OUTDOORCHEF can only supply spare parts and honour warranty returns when the serial number is available.

### Achtung

Bitte notieren Sie auf der Rückseite Ihrer Gebrauchsanweisung die Serien-Nummer. Je nach Grillmodell finden Sie die Nummer auf dem Datensticker, welcher sich entweder am Grillgestell oder auf der Bodenplatte befindet. OUTDOORCHEF kann Garantie und Ersatzteilieferungen nur mit der Serien-Nummer bearbeiten.

# Porto



THE BARBECUE COMPANY

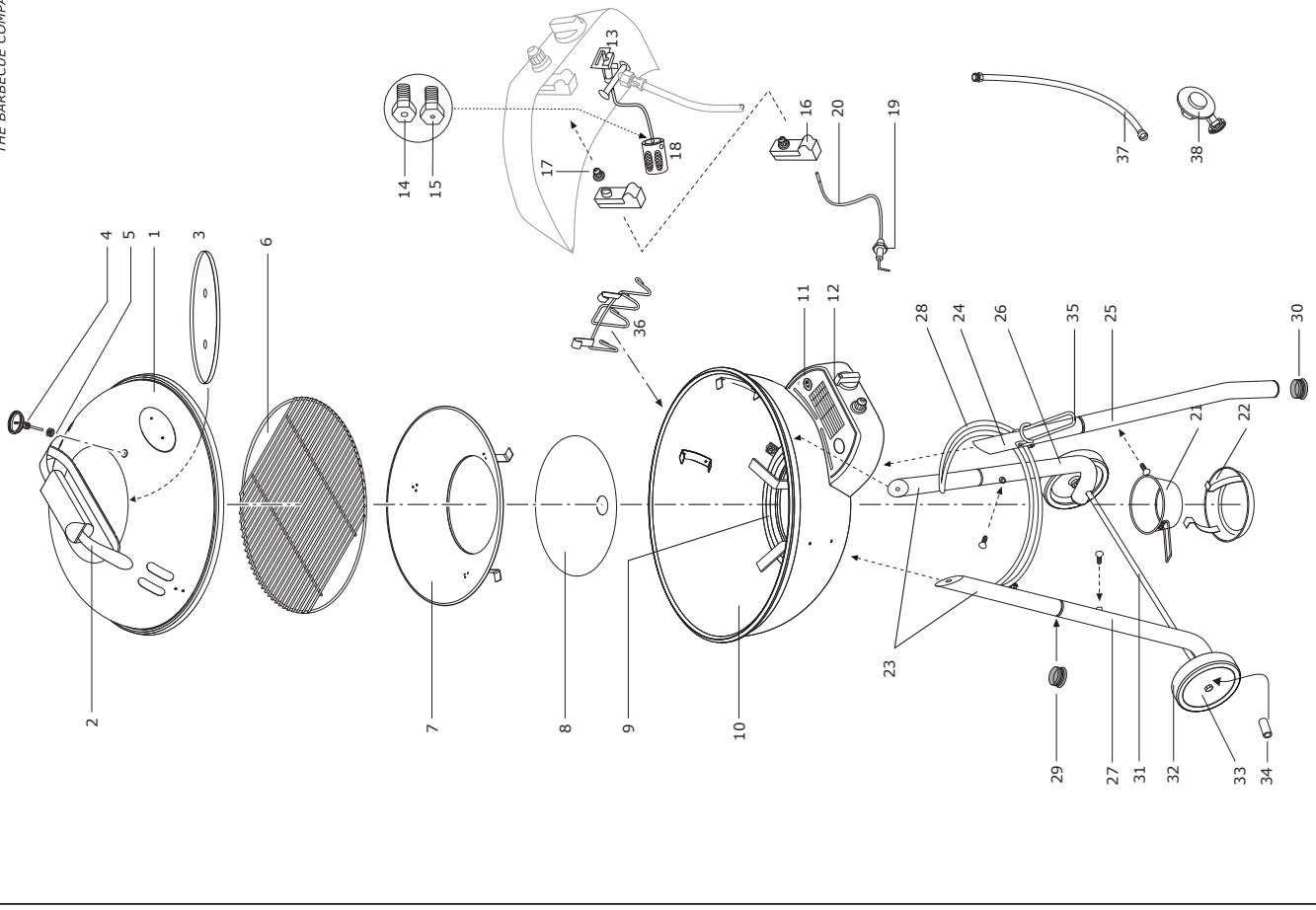

# Porto

B	Lid	Deckel
Pos.	Art. Nr.	Description
B1	18.370.93	Protection washer lid handle
B2	18.370.76	Teflonwasher
B3	18.370.62	U-Scheibe
B4	18.370.43	Nut

D	Valve assembly & Panel	Ventilsatz & Konsole
Pos.	Art. Nr.	Description
D1	18.370.05	Schraube
D2	18.371.01	Screw
D3	18.371.02	Washer
D4	18.371.03	Teflonwasher
D5	18.370.86	Teflonwasher
D6	18.371.00	Screw

E	Bowl	Kugel
Pos.	Art. Nr.	Description
E1	18.370.10	Schraube
E2	18.370.62	U-Scheibe
E3	18.370.76	Teflonwasher
E4	18.370.94	Protection washer bowl

F	Piezo electrode	Piezo-Elektrode
Pos.	Art. Nr.	Description
F1	18.371.01	Schraube
F2	18.371.02	Washer
F3	18.371.03	Teflonwasher
F4	18.371.04	Spring washer
F5	18.370.48	Nut
F6	18.371.11	Holder piezo electrode

# Porto



THE BARBECUE COMPANY

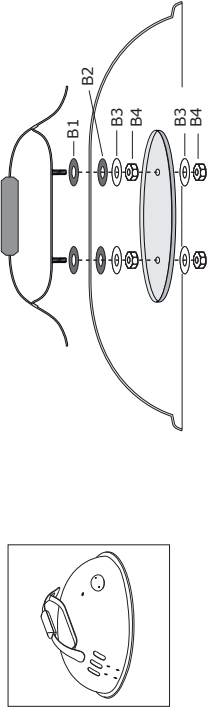

**B**

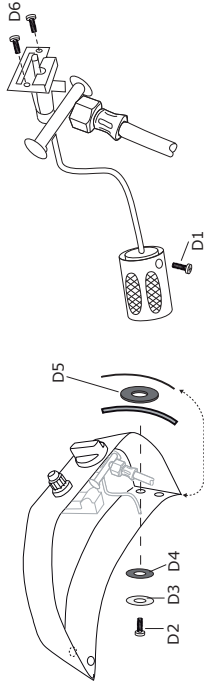

**D**

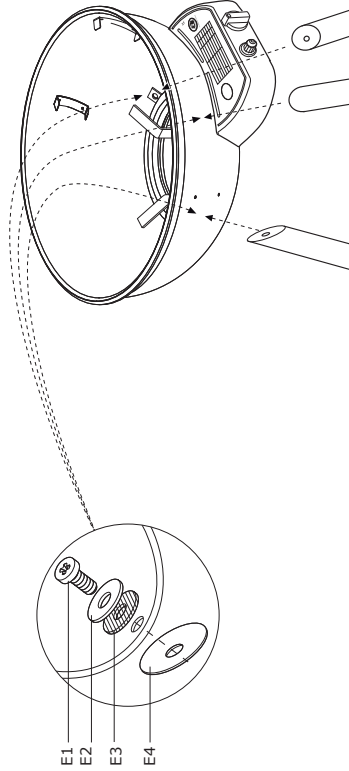

**E**

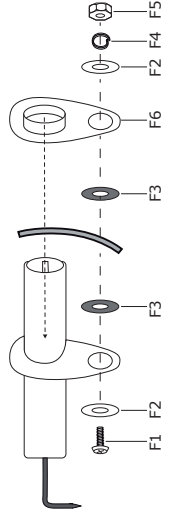

**F**

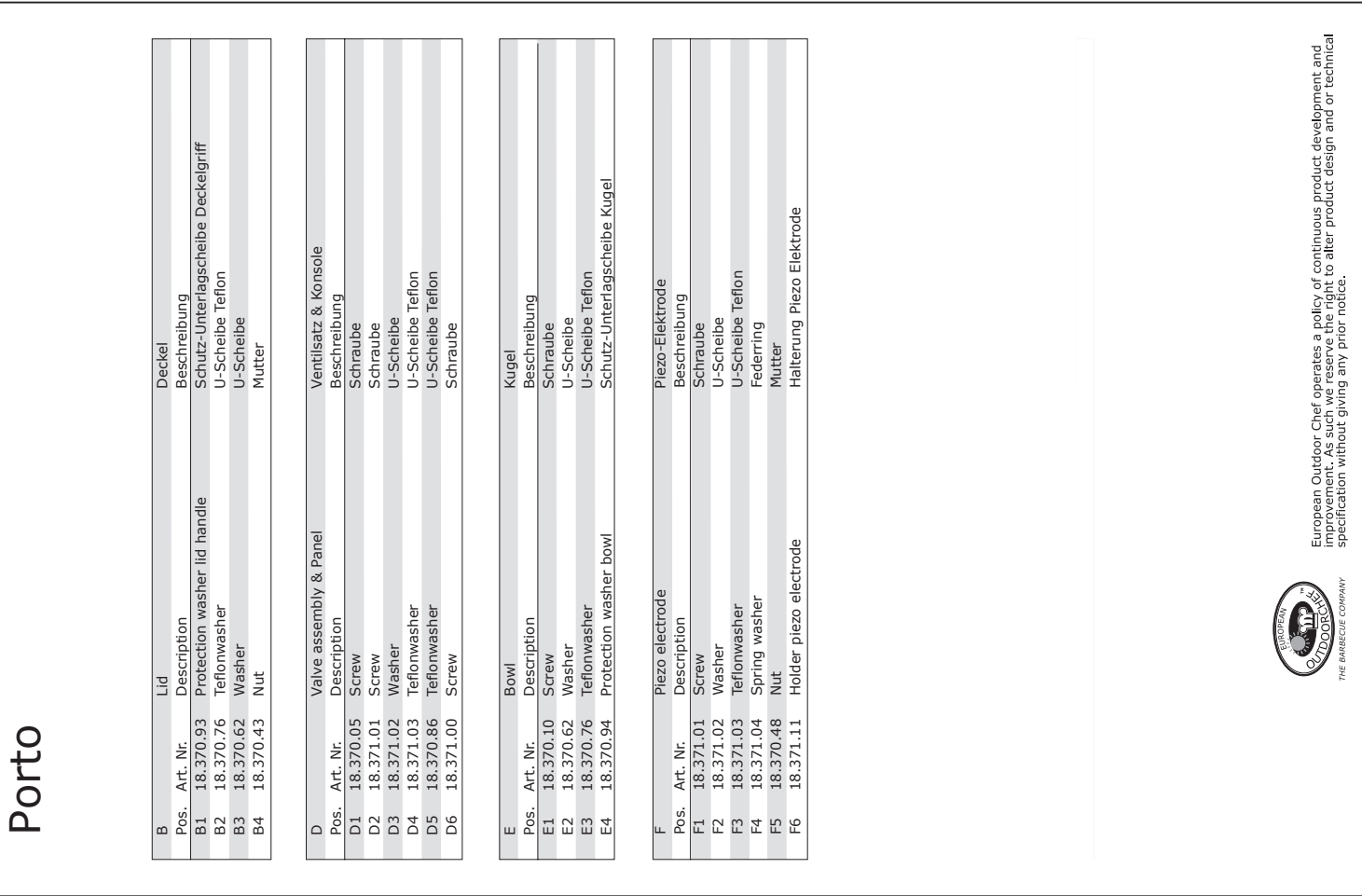
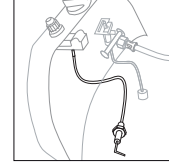

European Outdoor Chef operates a policy of continuous product development and improvement. As such we reserve the right to alter product design and or technical specification without giving any prior notice.



THE BARBECUE COMPANY



## Spare Parts

Pos. Art. Nr.	Description	Beschreibung
1	18.350.58 Lid 570 LH, onyx	Deckel 570 LH, onyx
2	18.322.35 Lid Handle titan-silver	Deckelgriff titan-silver
3	18.323.00 Heat Shield	Hitzeschild
4	18.320.10 Lid Hinge	Deckelscharnier
5	18.850.13 Heat Indicator °C/°F	Temperatur Anzeige °C/°F
6	18.850.14 Frame for heat indicator	Rahmen zu Temperaturanzeiger
7	18.850.12 Heat indicator-Nut	Temperaturanzeiger-Befestigungsmutter
8	18.320.00 Cooking Grid for Kettle Grill	Grillrost zu Kugelgrill
9	18.320.02 Large Funnel for Kettle Grill	Grosser Trichter zu Kugelgrill
10	18.320.03 Small Funnel for Kettle Grill	Kleiner Trichter zu Kugelgrill
11	18.350.15 Bowl LH DB Pt, onyx	Kugel LH DB Pt, onyx
12	18.614.04 Control Knob	Gasregulier-Knopf
13	18.614.05 Frame for control knob	Rahmen zu Gasregulier-Knopf
14	18.322.88 Control Panel DB Kettle Grill titan-silver	Bedienkonsole DB Kugelgrill titan-silver
15	18.340.52 Valve Assembly with Bundy DB for Kettle Grill	Ventilsatz mit Bundy DB zu Kugelgrill
16	18.340.58 Venturi-protection DB small	Venturischutz DB klein
17	18.340.57 Venturi-protection DB & SB	Venturischutz DB & SB
18	18.340.14 Injector small Burner for Kettle Grill 30mbar mark: BF	Düse für kleinen Brenner zu Kugelgrill 30mbar mark: BF
19	18.340.13 Injector small Burner for Kettle Grill 50mbar mark: AF	Düse für kleinen Brenner zu Kugelgrill 50mbar mark: AF
20	18.340.18 Injector large Burner for Kettle Grill 30mbar mark: BT	Düse für grossen Brenner zu Kugelgrill 30mbar mark: BT
21	18.340.17 Injector large Burner for Kettle Grill 50mbar mark: AT	Düse für grossen Brenner zu Kugelgrill 50mbar mark: AT
22	18.340.08 Pulse ignitor DB complete	Elektro-Zündung DB Komplett
23	18.360.21 Push button ignitor	Druckknopf Zündung
24	18.340.02 Burner small 30mbar	Brenner klein 30mbar
25	18.340.45 Burner small 50mbar	Brenner klein 50mbar
26	18.340.00 Burner large 30mbar	Grosser Brenner 30mbar
27	18.340.44 Burner large 50mbar	Grosser Brenner 50mbar
28	18.323.04 Drip Pan	Fettauffangschale
29	18.323.05 Drip Pan carrier	Zündungskabel
30	18.340.12 Ignition wire	Piezo-Elektrode grosser Brenner zu Kugelgrill
31	18.340.10 Piezo Electrode small Burner for Kettle Grill	Piezo-Elektrode kleiner Brenner zu Kugelgrill
32	18.610.17 BBQ base Steak House Grill, black	Grillgehäuse Steak House Grill, schwarz
33	18.600.47 Control Panel Steak House Grill titan-silver	Bedienkonsole Steak House Grill titan-silver
34	18.340.54 Valve Assembly Steak House Grill	Ventilsatz Steak House Grill
35	18.612.29 Burner Steak House Grill	Brenner Steak House Grill
36	18.340.55 Connection tube Steak House Grill	Verbindungsrohr Steak House Grill
37	18.600.49 Flame Protection Steak House Grill	Flammenschutz Steak House Grill
38	18.612.01 Piezo-Electrode Steak House Grill	Piezo-Elektrode Steak House Grill
39	18.612.22 Ignition wire, short	Zündungskabel, kurz
40	18.340.25 Injector Steak for House Grill 30mbar mark: BK	Düse Steak House Grill 30mbar Markierung: BK
41	18.340.26 Injector Steak for House Grill 50mbar mark: AH	Düse Steak House Grill 50mbar Markierung: AH
42	18.600.32 Cooking Grid for Steak House Grill	Grillrost Steak zu House Grill
43	18.600.02 Collection Sheet for Steak House Grill	Fettauffang-Blech zu Steak House Grill
44	18.320.89 Drip Pan for Steak House Grill	Fettauffang-Schale zu Steak House Grill
45	18.360.16 Granite stone	Granit Platte
46	18.323.12 Drawer titan-silver	Schublade titan-silver
47	18.322.90 Side Table Frame titan-silver	Seitentablar-Rahmen titan-silver
48	18.322.86 Bowl Frame titan-silver	Kugelrahmen titan-silver
49	18.322.48 Legs left titan-silver	Beine links titan-silver
50	18.322.53 Legs right titan-silver	Beine rechts titan-silver
51	18.323.32 Guidance bar	Plattenführung
52	18.322.42 Lower Frame titan-silver	Unterer Rahmen titan-silver
53	18.360.34 Puffer	Puffer
54	18.322.29 Bottle Jacket black	Flaschenschale schwarz
55	18.322.43 Bottom Shelf Kettle-side left black	Bodenplatte Kugelseite links schwarz
56	18.322.91 Bottom Shelf Kettle-side right black	Bodenplatte Kugelseite rechts schwarz
57	18.322.44 Bottom Shelf for Steak House Grill black	Bodenplatte zu Steak House Grill schwarz
58	18.360.27 Caster with Brake	Rad mit Bremse
59	18.322.94 Tool holder	Besteckhalterung
60	18.379.04 Hardware-Set	Schrauben-Set
individual	Gas Hose	Gas Schlauch
individual	Gas Regulator	Gasdruckregler

### Attention

Please write your serial number on the backside of the manual for future reference. You will find the number on the data plate attached to the trolley or the bottom plate depending on the grill model. OUTDOORCHEF can only supply spare parts and honour warranty returns when the serial number is available.

## Ersatzteil-Liste

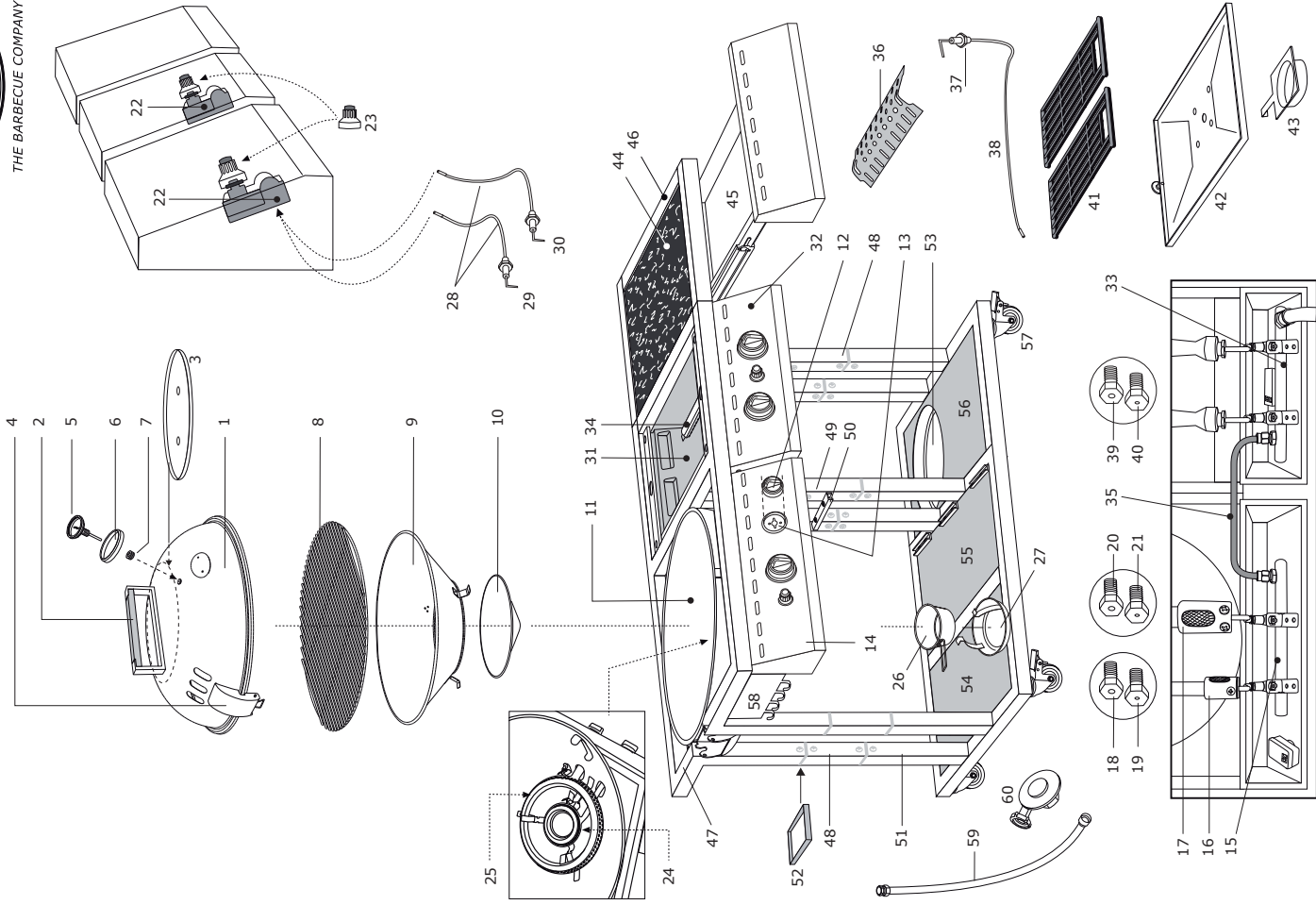

# Venezia

B	Lid	Deckel
Pos.	Art. Nr.	Beschreibung
B1	18.370.86	Protection washer lid handle
B2	18.370.76	Teflonwasher
B3	18.370.62	Washer
B4	18.370.39	Twin screw Lid handle
B5	18.370.43	Nut

D	Valve assembly & Panel	Ventilsatz & Konsole
Pos.	Art. Nr.	Beschreibung
D1	18.370.05	Screw
D2	18.371.00	Schraube

F	Piezo electrode	Piezo-Elektrode
Pos.	Art. Nr.	Beschreibung
F1	18.371.01	Screw
F2	18.371.02	Washer
F3	18.371.03	Teflonwasher
F4	18.371.04	Spring washer
F5	18.370.48	Nut
F6	18.371.11	Holder piezo electrode

# Venezia



THE BARBECUE COMPANY

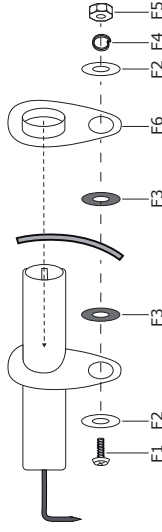
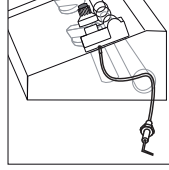
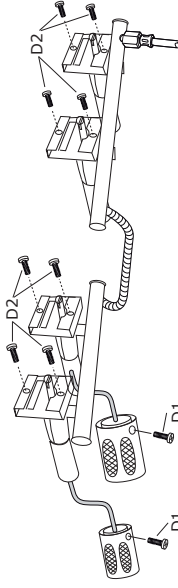
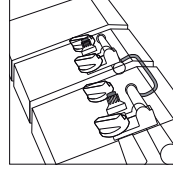
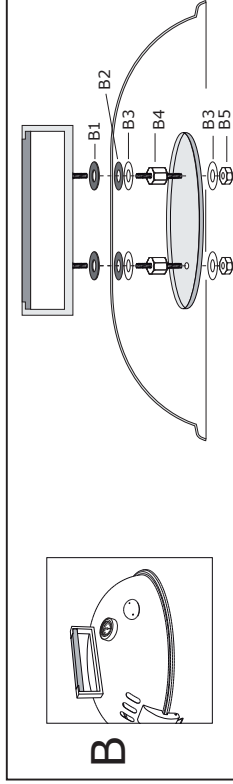

# AUCKLAND

## Spare Parts

## Ersatzteil-Liste

Pos.	Art. Nr.	Description	Beschreibung
1	18.610.10	Lid, stainless steel	Deckel, Edelstahl
2	18.600.50	Lid handle tube, stainless steel	Griffrohr, Edelstahl
3	18.850.16	Heat indicator °C/°F - RTG, complete	Temperaturanzeiger °C/°F - RTG, Komplett
4	18.850.17	Heat indicator-Nut - RTG	Temperaturanzeiger-Befestigungsmutter - RTG
5	18.600.01	Warming grid	Warmhalte-Rost
6	18.600.02	Cooking grid	Grillrost
7	18.600.16	Cast Iron plate	Gusseisen-Platte
8	18.600.49	Flame protection	Flammenschutz
9	18.612.29	Burner	Brenner
10	18.612.03	Sear burner	Infrarot-Brenner
11	18.612.25	Injector sear burner 30mbar mark: BP	Düse Infrarot-Brenner 30mbar Markierung: BP
12	18.612.26	Injector sear burner 50mbar mark: AP	Düse Infrarot-Brenner 50mbar Markierung: AP
13	18.600.24	Control panel, stainless steel	Bedienungskonsole, Edelstahl
14	18.612.31	Valve Assembly 4B ++	Ventilsatz 4B ++
15	18.612.06	Injector 30mbar mark: BE	Düse 30mbar Markierung: BE
16	18.612.07	Injector 50mbar mark: AE	Düse 50mbar Markierung: AE
17	18.614.01	Control knob	Gasregulier-Knopf
18	18.614.03	Gas knob frame main burner	Rahmen für Gasregulier-Knopf Hauptbrenner
19	18.612.01	Piezo electrode main burner	Piezo-Elektrode Hauptbrenner
20	18.612.20	Ignition wire long (side burner/sear burner)	Zündkabel lang (Seitenbrenner/Infrarot Brenner)
21	18.612.21	Ignition wire medium	Zündkabel medium
22	18.612.22	Ignition wire short	Zündkabel kurz
23	18.612.04	Piezo electrode side burner	Piezo-Elektrode Infrarot-Brenner
24	18.612.08	Puls ignition complete	Elektrozündung Komplett
25	18.360.22	Push button ignitor	Druckknopf Zündung
26	18.610.14	BBQ base, black	Grill Gehäuse, schwarz
27	18.600.05	Collection sheet	Fettauffang-Blech
28	18.320.89	Drip pan	Fettauffang-Schale
29	18.600.22	Side table left SB, black	Seitentablar links SB, schwarz
30	18.600.23	Side table right, black	Seitentablar rechts, schwarz
31	18.323.24	Towel rail RTG	Handtuch-Halter RTG
32	18.323.25	Paper roll holder	Papierrollen-Halter
33	18.380.21	Granite stone side tables, Shanxi black	Granitstein Seitentablare, Shanxi black
34	18.614.04	Control Knob Side Burner	Gasregulier-Knopf Seitenbrenner
35	18.614.05	Gas knob frame side burner	Rahmen für Gasregulier-Knopf Seitenbrenner
36	18.340.60	Side burner	Seitenbrenner
37	18.323.13	Side burner grate	Rost zu Seitenbrenner
38	18.340.25	Injector side burner 30mbar mark: BK	Düse Seitenbrenner 30mbar mark: BK
39	18.340.24	Injector side burner 50mbar mark: AG	Düse Seitenbrenner 50mbar mark: AG
40	18.340.33	Piezo electrode side burner	Piezo-Elektrode Seitenbrenner
41	18.612.05	Connection Hose side burner	Verbindungsrohr Seitenbrenner
42	18.600.18	Leg front right / rear left, stainless steel	Bein vorne rechts / hinten links, Edelstahl
43	18.600.19	Leg front left / rear right, stainless steel	Bein vorne links / hinten rechts, Edelstahl
44	18.600.09	Bottom sheet, black	Bodenplatte, schwarz
45	18.600.25	Bottle fixation, black	Flaschenhalterung, schwarz
46	18.360.14	Bottle strap	Flaschengurt
47	18.600.15	Rear cabinet sheet, black	Hintere Kastenwand, schwarz
48	18.600.56	Door left, black	Türe links, schwarz
49	18.600.57	Door right, black	Türe rechts, schwarz
50	18.600.26	Door magnet	Türmagnet
51	18.600.58	Cabinet sheet left, black	Kastenwand links, schwarz
52	18.600.75	Cabinet sheet right, black	Kastenwand rechts, schwarz
53	18.600.20	Door frame	Türrahmen
54	18.600.21	Cabinet shelf, black	Kastentablar, schwarz
55	18.614.02	Caster with brake	Rad mit Bremse
56	18.323.14	Door handle	Türgriff
57	18.378.98	Hardware set	Schrauben-Set
58	individual	Gas hose	Gas Schlauch
59	individual	Gas regulator	Gasdruck-Regler

# AUCKLAND

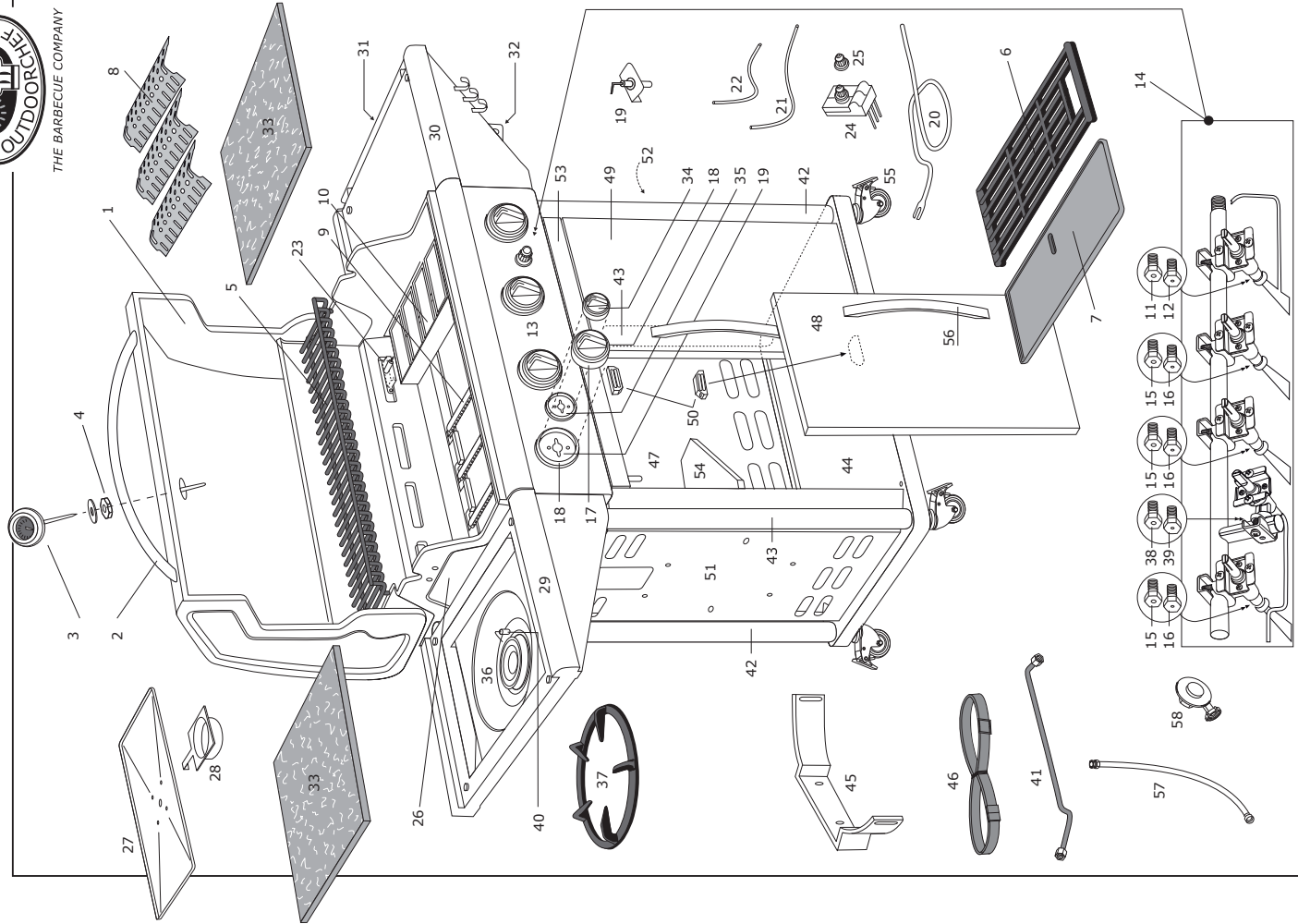

B	Pos.	Art. Nr.	Lid	Description	Deckel
B1	18.371.08		Screw-cup-washer	Schraubung	
B2	18.370.04		Screw	Schrauben-Schalen-Unterlagscheibe	
B3	18.370.66		Washer	U-Scheibe	
B4	18.850.17		Nut	Mutter	

C	Pos.	Art. Nr.	Piezo electrode side burner	Description	Piezo-Elektrode Seitenbrenner
C1	18.370.31		Screw	Schraubung	
C2	18.370.50		Nut	Mutter	

D	Pos.	Art. Nr.	Piezo electrode & Burner fixation	Description	Piezo-Elektrode & Brenner Befestigung
D1	18.370.32		Screw	Schraubung	
D2	18.371.09		Locking pin	Sicherungsstift	

### Attention

Please write your serial number on the backside of the manual for future reference. You will find the number on the data plate attached to the trolley or the bottom plate depending on the grill model. OUTDOORCHEF can only supply spare parts and honour warranty returns when the serial number is available.

### Achtung

Bitte notieren Sie auf der Rückseite Ihrer Gebrauchsanweisung die Serien-Nummer. Je nach Grillmodell finden Sie die Nummer auf dem Datensticker, welcher sich entweder am Grillgestell oder auf der Bodenplatte befindet. OUTDOORCHEF kann Garantie und Ersatzteil-lieferungen nur mit der Serien-Nummer bearbeiten.

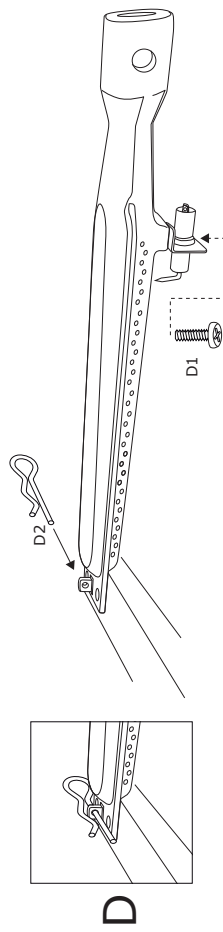
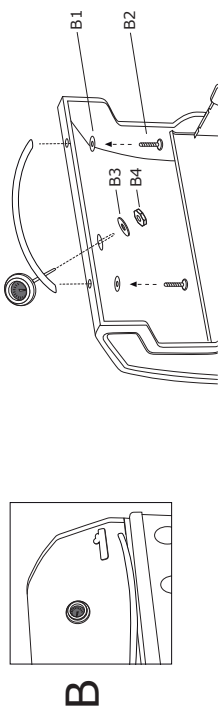



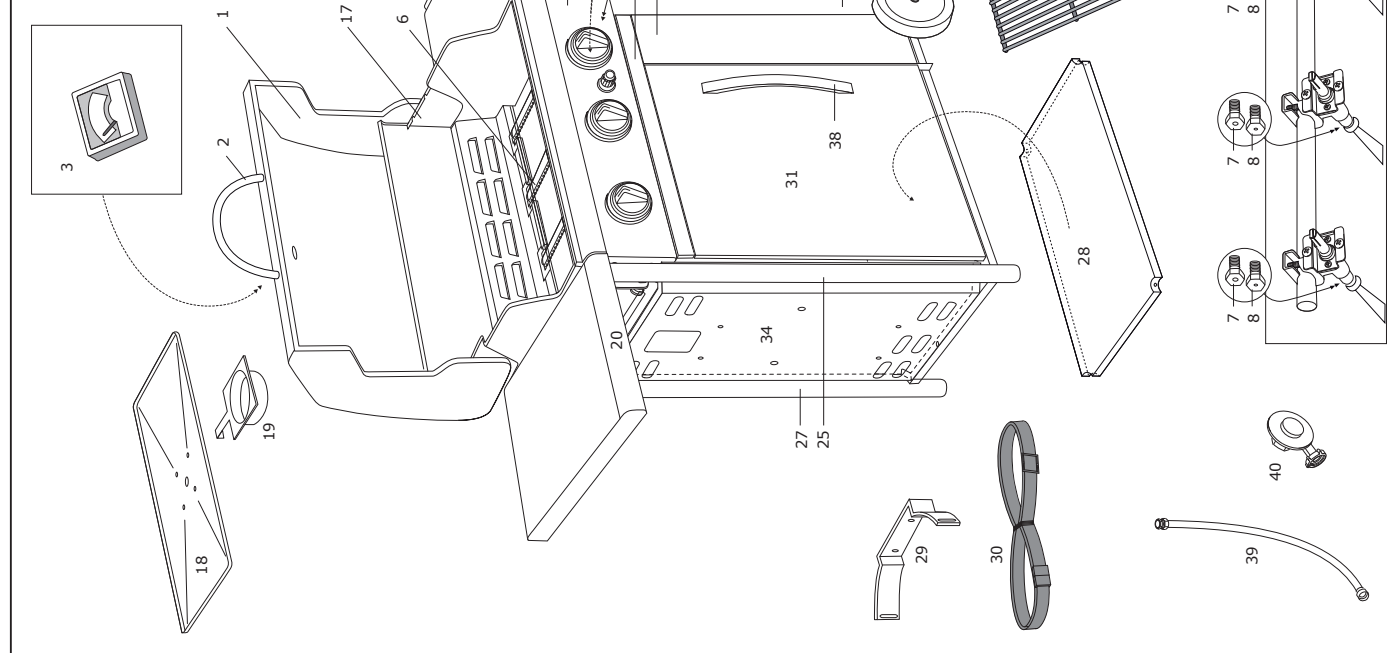

## CAIRNS

### Spare Parts

### Ersatzteil-Liste

Pos.	Art. Nr.	Description	Beschreibung
1	18.610.15	Lid, black	Deckel, schwarz
2	18.600.61	Lid handle tube, stainless steel	Griffrohr, Edelstahl
3	18.850.08	Heat indicator °C/°F - rectangular	Temperatur Anzeige °C/°F - rechteckig
4	18.600.62	Cooking grid enameled	Grillrost emailiert
5	18.600.49	Flame protection	Flammenschutz
6	18.612.29	Burner	Brenner
7	18.612.13	Injector 30mbar mark: BD	Düse 30mbar Markierung: BD
8	18.612.14	Injector 50mbar mark: AD	Düse 50mbar Markierung: AD
9	18.600.71	Control panel, black	Bedienungskonsole, schwarz
10	18.612.33	Valve Assembly 3B	Ventilsatz 3B
11	18.614.01	Control knob	Rahmen für Gasregulier-Knopf
12	18.614.03	Control knob frame	Piezo-Elektrode
13	18.612.01	Piezo electrode	Zündkabel kurz
14	18.612.22	Ignition wire short	Elektrozündung Komplet
15	18.340.37	Puls ignition complete	Druckknopf Zündung
16	18.360.22	Push button ignitor	Grill Gehäuse, Schwarz
17	18.610.16	BBQ base, black	Fettauffang-Blech
18	18.600.43	Collection sheet	Fettauffang-Schale
19	18.320.89	Drip pan	Seitentablar links, schwarz
20	18.600.52	Side table left, black	Seitentablar rechts, schwarz
21	18.600.53	Side table right, black	Besteck-Halter RTG
22	18.323.23	Tool holder RTG	Handtuch-Halter RTG
23	18.323.24	Towel rail RTG	Bein vorne rechts, schwarz
24	18.600.64	Leg front right, black	Bein vorne links, schwarz
25	18.600.65	Leg front left, black	Bein hinten rechts, schwarz
26	18.600.72	Leg rear right, black	Bein hinten links, schwarz
27	18.600.73	Leg rear left, black	Bodenplatte, schwarz
28	18.600.66	Bottom sheet, black	Flaschenhalterung, Schwarz
29	18.600.25	Bottle fixation, black	Flaschengurt
30	18.360.14	Bottle strap	Türe, schwarz
31	18.600.67	Door, black	Türrahmen, schwarz
32	18.600.69	Door frame, black	Türrahmen rechts, schwarz
33	18.600.70	Door frame right, black	Kastenwand links, schwarz
34	18.600.68	Cabinet sheet left, black	Kastenwand rechts, schwarz
35	18.600.74	Cabinet sheet right, black	Rad
36	18.360.38	Wheel	Radabdeckung
37	18.360.39	Wheel cover	Türgriff
38	18.323.14	Door handle	Schrauben-Set
39	18.378.95	Hardware set	Gas Schlauch
40	individual	Gas regulator	Gasdruck-Regler

#### Attention

Please write your serial number on the backside of the manual for future reference. You will find the number on the data plate attached to the trolley or the bottom plate depending on the grill model. OUTDOORCHEF can only supply spare parts and honour warranty returns when the serial number is available.

#### Achtung

Bitte notieren Sie auf der Rückseite Ihrer Gebrauchsanweisung die Serien-Nummer. Je nach Grillmodell finden Sie die Nummer auf dem Datensticker, welcher sich entweder am Grillgestell oder auf der Bodenplatte befindet. OUTDOORCHEF kann Garantie und Ersatzteil-lieferungen nur mit der Serien-Nummer bearbeiten.

# CAIRNS

B	Pos.	Art. Nr.	Lid Description
	B1	18.371.07	Protection washer lid handle
	B2	18.370.76	Teflonwasher
	B3	18.371.08	Screw-cup-washer
	B4	18.370.08	Screw

D	Pos.	Art. Nr.	Piezo electrode & Burner fixation Description
	D1	18.370.32	Screw
	D2	18.371.09	Locking pin

# CAIRNS



THE BARBECUE COMPANY

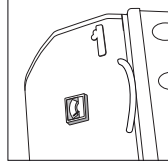

B

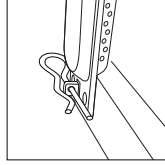
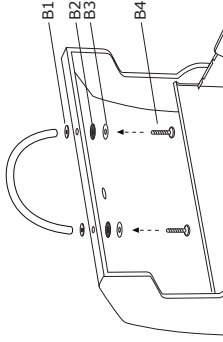

D

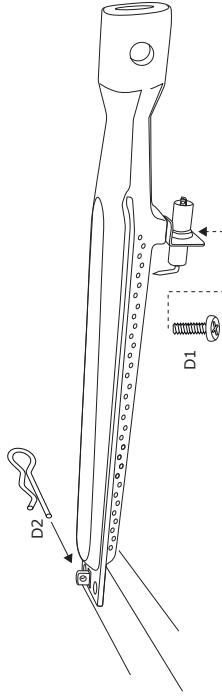

# CANBERRA

## Spare Parts

Pos.	Art. Nr.	Description	Beschreibung
1	18.610.11	Lid, black	Deckel, schwarz
2	18.600.50	Lid handle tube, stainless steel	Griffrohr, Edelstahl
3	18.850.16	Heat indicator °C/°F - RTG, complete	Temperaturanzeiger °C/°F - RTG, Komplett
4	18.850.17	Heat indicator-Nut - RTG	Temperaturanzeiger-Befestigungsmutter - RTG
5	18.600.01	Warming grid	Warmhalte-Rost
6	18.600.02	Cooking grid	Grillrost
7	18.600.16	Cast Iron plate	Flammenschutz
8	18.600.49	Flame protection	Brenner
9	18.612.29	Burner	Düse 30mbar Markierung: BE
10	18.612.06	Injector 30mbar mark: BE	Düse 50mbar Markierung: AE
11	18.612.07	Injector 50mbar mark: AE	Bedienungskonsole, schwarz
12	18.600.51	Control panel, black	Ventilsatz 4B
13	18.612.11	Valve Assembly 4B	Gasregulier-Knopf
14	18.614.01	Control knob	Rahmen für Gasregulier-Knopf Hauptbrenner
15	18.614.03	Gas knob frame main burner	Piezo-Elektrode
16	18.612.01	Piezo electrode	Zündkabel medium
17	18.612.21	Ignition wire medium	Zündkabel kurz
18	18.612.22	Ignition wire short	Elektrozündung Komplett
19	18.612.10	Puls ignition complete	Druckknopf Zündung
20	18.360.22	Push button ignitor	Grill Gehäuse, schwarz
21	18.610.12	BBQ base, black	Fettauffang-Blech
22	18.600.05	Collection sheet	Fettauffang-Schale
23	18.320.89	Drip pan	Seitentablar links schwarz
24	18.600.52	Side table left black	Seitentablar rechts schwarz
25	18.600.53	Side table right black	Besteck-Halter RTG
26	18.323.23	Tool holder RTG	Handtuch-Halter RTG
27	18.323.24	Towel rail RTG	Bein vorne rechts / hinten links, schwarz
28	18.600.54	Leg front right / rear left, black	Bein vorne links / hinten rechts, schwarz
29	18.600.55	Leg front left / rear right, black	Bodenplatte, schwarz
30	18.600.09	Bottom sheet, black	Flaschenhalterung, schwarz
31	18.600.25	Bottle fixation, black	Fiaschengürt
32	18.360.14	Bottle strap	Hinterer Kastenwand, schwarz
33	18.600.15	Rear cabinet sheet, black	Türe links, schwarz
34	18.600.56	Door left, black	Türe rechts, schwarz
35	18.600.57	Door right, black	Türmagnet
36	18.600.26	Door magnet	Kastenwand links, schwarz
37	18.600.58	Cabinet sheet left, black	Kastenwand rechts, schwarz
38	18.600.75	Cabinet sheet right, black	Türrahmen
39	18.600.20	Door frame	Kastentablar
40	18.600.21	Cabinet shelf	Rad mit Bremse
41	18.614.02	Caster with brake	Türgriff
42	18.323.14	Door handle	Schrauben-Set
43	18.378.96	Hardware set	Gas Schlauch
44	individual	Gas hose	Gasdruck-Regler
44	individual	Gas regulator	

### Attention

Please write your serial number on the backside of the manual for future reference. You will find the number on the data plate attached to the trolley or the bottom plate depending on the grill model. OUTDOORCHEF can only supply spare parts and honour warranty returns when the serial number is available.

### Achtung

Bitte notieren Sie auf der Rückseite Ihrer Gebrauchsanweisung die Seriennummer. Je nach Grillmodell finden Sie die Nummer auf dem Datenstück, welcher sich entweder am Grillgestell oder auf der Bodenplatte befindet. OUTDOORCHEF kann Garantie und Ersatzteil-lieferungen nur mit der Seriennummer bearbeiten.

# CANBERRA



THE BARBECUE COMPANY

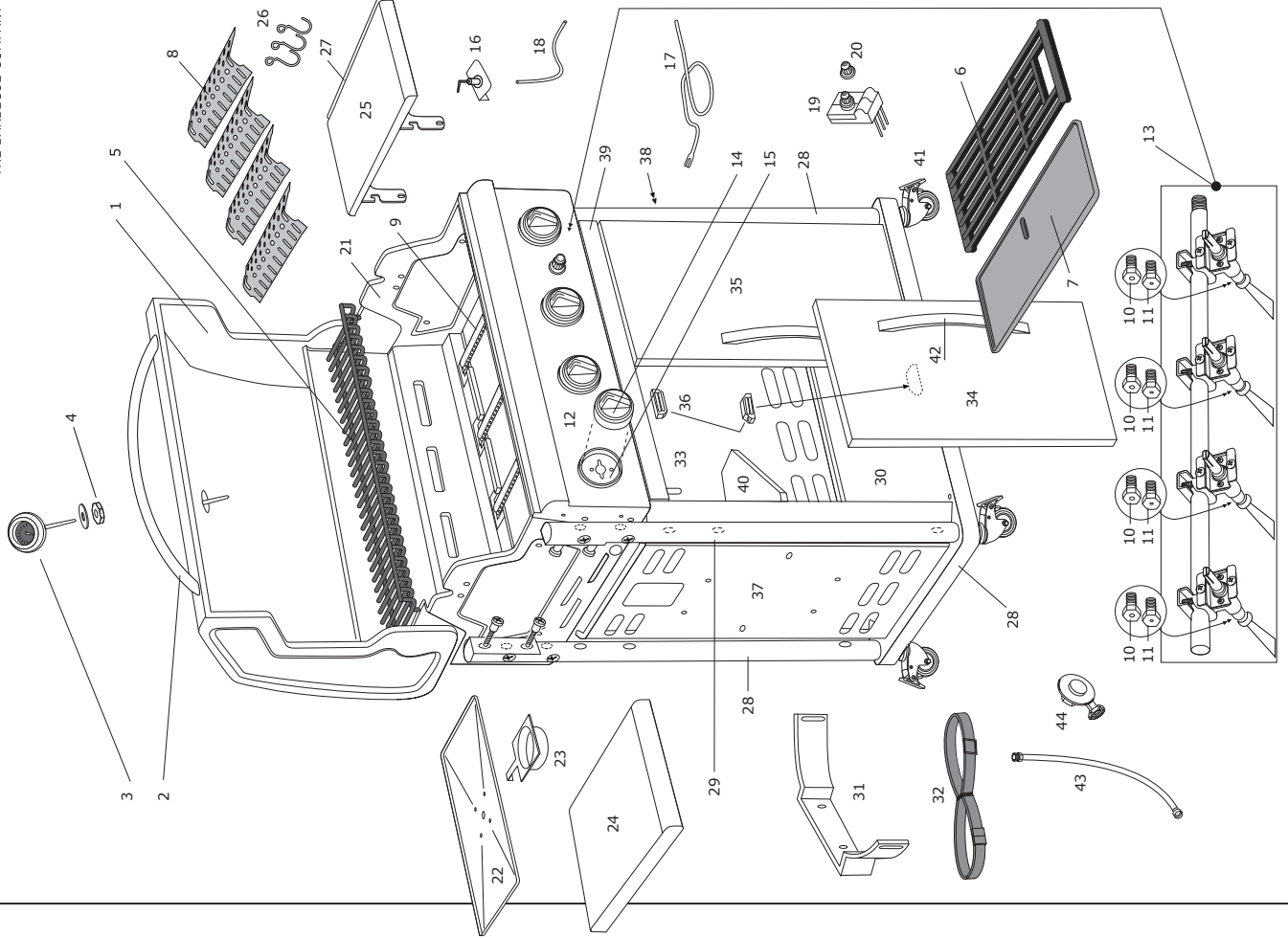

# CANBERRA

B	Lid	Deckel
Pos.	Art. Nr.	Description
B1	18.370.95	Protection washer lid handle
B2	18.370.76	Teflonwasher
B3	18.371.08	Screw-cup-washer
B4	18.370.04	Screw

D	Piezo electrode & Burner fixation	Piezo-Elektrode & Brenner Befestigung
Pos.	Art. Nr.	Description
D1	18.370.32	Screw
D2	18.371.09	Locking pin

# CANBERRA



THE BARBECUE COMPANY

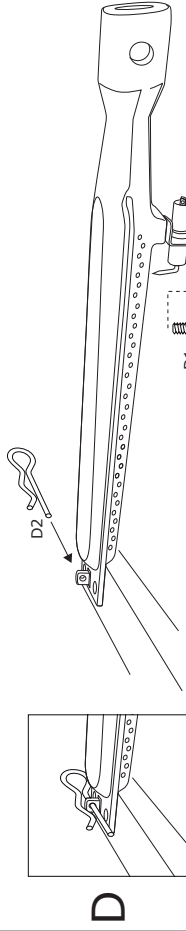
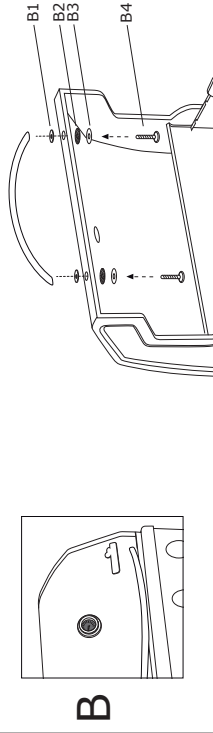

# HAMILTON



THE BARBECUE COMPANY

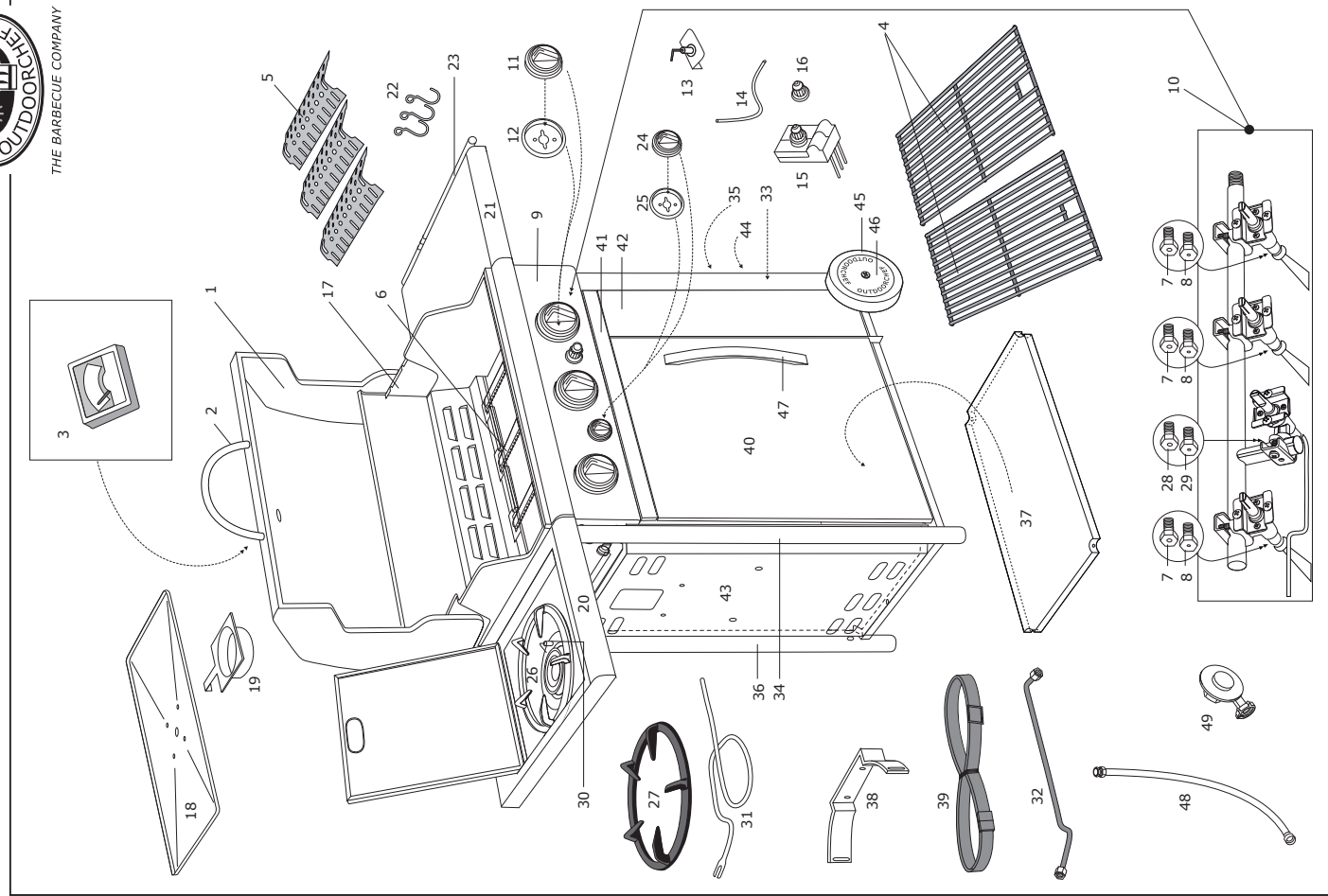

## HAMILTON

### Spare Parts

### Ersatzteil-Liste

Pos.	Art. Nr.	Description	Beschreibung
1	18.610.15	Lid, black	Deckel, schwarz
2	18.600.61	Lid handle tube, stainless steel	Griffrohr, Edelstahl
3	18.850.08	Heat indicator °C/°F - rectangular	Temperatur Anzeige °C/°F - rechteckig
4	18.600.62	Cooking grid enameled	Grillrost emailliert
5	18.600.49	Flame protection	Flammenschutz
6	18.612.29	Burner	Brenner
7	18.612.13	Injector 30mbar mark: BD	Düse 30mbar Markierung: BD
8	18.612.14	Injector 50mbar mark: AD	Düse 50mbar Markierung: AD
9	18.600.63	Control panel, black	Bedienungskonsole, schwarz
10	18.612.32	Valve Assembly 3B +	Ventilsatz 3B +
11	18.614.01	Control knob	Gasregulier-Knopf
12	18.614.03	Control knob frame	Rahmen für Gasregulier-Knopf
13	18.612.01	Piezo electrode	Piezo-Elektrode
14	18.612.22	Ignition wire short	Zündkabel kurz
15	18.612.10	Puls ignition complete	Elektrozündung Komplet
16	18.360.22	Push button ignitor	Druckknopf Zündung
17	18.610.16	BBQ base, black	Grill Gehäuse, Schwarz
18	18.600.43	Collection sheet	Fettauffang-Blech
19	18.320.89	Drip pan	Fettauffang-Schale
20	18.600.60	Side table left SB, black	Seitentablar links SB, schwarz
21	18.600.53	Side table right, black	Seitentablar rechts, schwarz
22	18.323.23	Tool holder RTG	Besteck-Halter RTG
23	18.323.24	Towel rail RTG	Handtuch-Halter RTG
24	18.614.04	Control Knob Side Burner	Gasregulier-Knopf Seitenbrenner
25	18.614.05	Gas knob frame side burner	Rahmen für Gasregulier-Knopf Seitenbrenner
26	18.340.60	Side burner	Seitenbrenner
27	18.323.13	Side burner grate	Rost zu Seitenbrenner
28	18.340.25	Injector side burner 30mbar mark: BK	Düse Seitenbrenner 30mbar mark: BK
29	18.340.24	Injector side burner 50mbar mark: AG	Düse Seitenbrenner 50mbar mark: AG
30	18.340.33	Piezo electrode side burner	Piezo-Elektrode Seitenbrenner
31	18.612.20	Ignition wire long	Zündkabel lang
32	18.612.30	Connection Hose side burner	Verbindungsrohr Seitenbrenner
33	18.600.64	Leg front right, black	Bein vorne rechts, schwarz
34	18.600.65	Leg front left, black	Bein hinten rechts, schwarz
35	18.600.72	Leg rear right, black	Bein hinten links, schwarz
36	18.600.73	Leg rear left, black	Bein hinten links, schwarz
37	18.600.66	Bottom sheet, black	Bodenplatte, schwarz
38	18.600.25	Bottle fixation, black	Flaschenhalterung, Schwarz
39	18.360.14	Bottle strap	Flaschengurt
40	18.600.67	Door, black	Türe, schwarz
41	18.600.69	Door frame, black	Türrahmen, schwarz
42	18.600.70	Door frame right, black	Türrahmen rechts, schwarz
43	18.600.68	Cabinet sheet left, black	Kastenwand links, schwarz
44	18.600.74	Cabinet sheet right, black	Kastenwand rechts, schwarz
45	18.360.38	Wheel	Rad
46	18.360.39	Wheel cover	Radabdeckung
47	18.323.14	Door handle	Türgriff
48	18.378.95	Hardware set	Schrauben-Set
49	individual	Gas hose	Gasdruck-Regler

### Attention

Please write your serial number on the backside of the manual for future reference. The number can be found on the underside of the control panel. OUTDOORCHEF can only supply spare parts and honour warranty returns when the serial number is available.

### Achtung

Bitte notieren Sie auf der Rückseite Ihrer Gebrauchsanweisung die Serien-Nummer. Je nach Grillmodell finden Sie die Nummer auf dem Datensticker, welcher sich entweder am Grillgestell oder auf der Bodenplatte befindet. OUTDOORCHEF kann Garantie und Ersatzteillieferungen nur mit der Serien-Nummer bearbeiten.



# HAMILTON

B	Pos.	Art. Nr.	Lid	Description
	B1	18.371.07	Deckel	Beschreibung
	B2	18.370.76	Protection washer lid handle	Schutz-Unterlagscheibe Deckelgriff
	B3	18.371.08	Teflonwasher	U-Scheibe Teflon
	B4	18.370.08	Screw-cup-washer	Schrauben-Schalen-Unterlagscheibe
			Screw	Schraube

C	Pos.	Art. Nr.	Piezo electrode side burner	Description
	C1	18.370.31	Piezo-Elektrode	Schraube
	C2	18.370.50	Mutter	Mutter

D	Pos.	Art. Nr.	Piezo electrode & Burner fixation	Description
	D1	18.370.32	Schraube	Schraube
	D2	18.371.09	Locking pin	Sicherungsstift

# HAMILTON

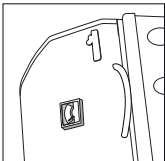
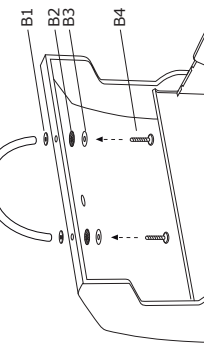

**B**

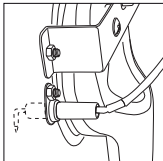
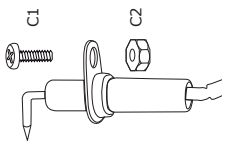

**C**

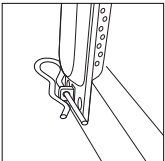
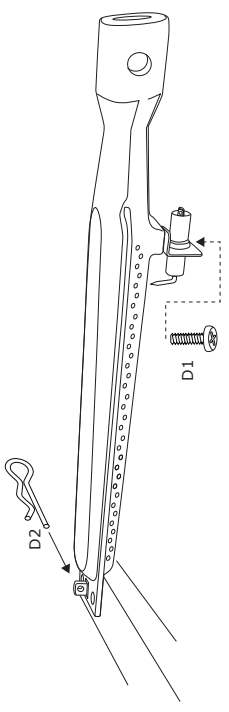

**D**



# PERTH

## Spare Parts

Pos.	Art. Nr.	Description	Beschreibung
1	18.610.11	Lid, black	Deckel, schwarz
2	18.600.50	Lid handle tube, stainless steel	Griffrohr, Edelstahl
3	18.850.16	Heat indicator °C/°F - RTG, complete	Temperatur Anzeiger °C/°F - RTG, Komplett
4	18.850.17	Heat indicator-Nut - RTG	Temperaturanzeiger-Befestigungsmutter - RTG
5	18.600.01	Warming grid	Warmhalte-Rost
6	18.600.02	Cooking grid	Grillrost
7	18.600.16	Cast Iron plate	Gusseisen-Platte
8	18.600.49	Flame protection	Flammenschutz
9	18.612.29	Burner	Brenner
10	18.612.06	Injector 30mbar mark: BE	Düse 30mbar Markierung: BE
11	18.612.07	Injector 50mbar mark: AE	Düse 50mbar Markierung: AE
12	18.600.59	Control panel, black	Bedienungskonsole, schwarz
13	18.612.12	Valve Assembly 4B +	Ventilsatz 4B +
14	18.614.01	Control knob	Gasregulier-Knopf
15	18.614.03	Control knob frame	Rahmen für Gasregulier-Knopf
16	18.612.01	Piezo electrode main burner	Piezo-Elektrode Hauptbrenner
17	18.612.20	Ignition wire long (side burner)	Zündkabel lang (Seitenbrenner)
18	18.612.21	Ignition wire medium	Zündkabel medium
19	18.612.22	Ignition wire short	Zündkabel kurz
20	18.612.08	Puls ignition complete	Elektrozündung Komplett
21	18.360.22	Push button ignitor	Druckknopf Zündung
22	18.610.12	BQ base, black	Grill Gehäuse, schwarz
23	18.600.05	Collection sheet	Fettauffang-Blech
24	18.320.89	Drip pan	Fettauffang-Schale
25	18.600.60	Side table left SB, black	Seitentablar links SB, schwarz
26	18.600.53	Side table right, black	Seitentablar rechts, schwarz
27	18.323.23	Tool holder RTG	Besteck-Halter RTG
28	18.323.24	Towel rail RTG	Handtuch-Halter RTG
29	18.614.04	Control knob Side Burner	Gasregulier-Knopf Seitenbrenner
30	18.614.05	Gas knob frame side burner	Rahmen für Gasregulier-Knopf Seitenbrenner
31	18.340.60	Side burner	Seitenbrenner
32	18.323.13	Side burner grate	Rost zu Seitenbrenner
33	18.340.25	Injector side burner 30mbar mark: BK	Düse Seitenbrenner 30mbar mark: BK
34	18.340.24	Injector side burner 50mbar mark: AG	Düse Seitenbrenner 50mbar mark: AG
35	18.340.33	Piezo electrode side burner	Piezo-Elektrode Seitenbrenner
36	18.612.30	Connection Hose side burner	Verbindungsrohr Seitenbrenner
37	18.600.54	Leg front right / rear left black	Bein vorne rechts / hinten links schwarz
38	18.600.55	Leg front left / rear right black	Bein vorne links / hinten rechts schwarz
39	18.600.09	Bottom sheet, black	Bodenplatte, schwarz
40	18.600.25	Bottle fixation, black	Flaschenhalterung, schwarz
41	18.360.14	Bottle strap	Flaschengurt
42	18.600.15	Rear cabinet sheet, black	Hinterer Kastenwand, schwarz
43	18.600.56	Door left, black	Türe links, schwarz
44	18.600.57	Door right, black	Türe rechts, schwarz
45	18.600.26	Door magnet	Türmagnet
46	18.600.58	Cabinet sheet left, black	Kastenwand links, schwarz
47	18.600.75	Cabinet sheet right, black	Kastenwand rechts, schwarz
48	18.600.20	Door frame	Türrahmen
49	18.600.21	Cabinet shelf	Kastentablar
50	18.614.02	Caster with brake	Rad mit Bremse
51	18.323.14	Door handle	Türgriff
52	individual	Hardware set	Schrauben-Set
53	individual	Gas hose	Gasschlauch
53	individual	Gas regulator	Gasdruck-Regler

### Attention

Please write your serial number on the backside of the manual for future reference. You will find the number on the data plate attached to the trolley or the bottom plate depending on the grill model. OUTDOORCHEF can only supply spare parts and honour warranty returns when the serial number is available.

### Achtung

Bitte notieren Sie auf der Rückseite Ihrer Gebrauchsanweisung die Serien-Nummer. Je nach Grillmodell finden Sie die Nummer auf dem Datensticker, welcher sich entweder am Grillgestell oder auf der Bodenplatte befindet. OUTDOORCHEF kann Garantie und Ersatzteil-lieferungen nur mit der Serien-Nummer bearbeiten.

# PERTH



THE BARBECUE COMPANY

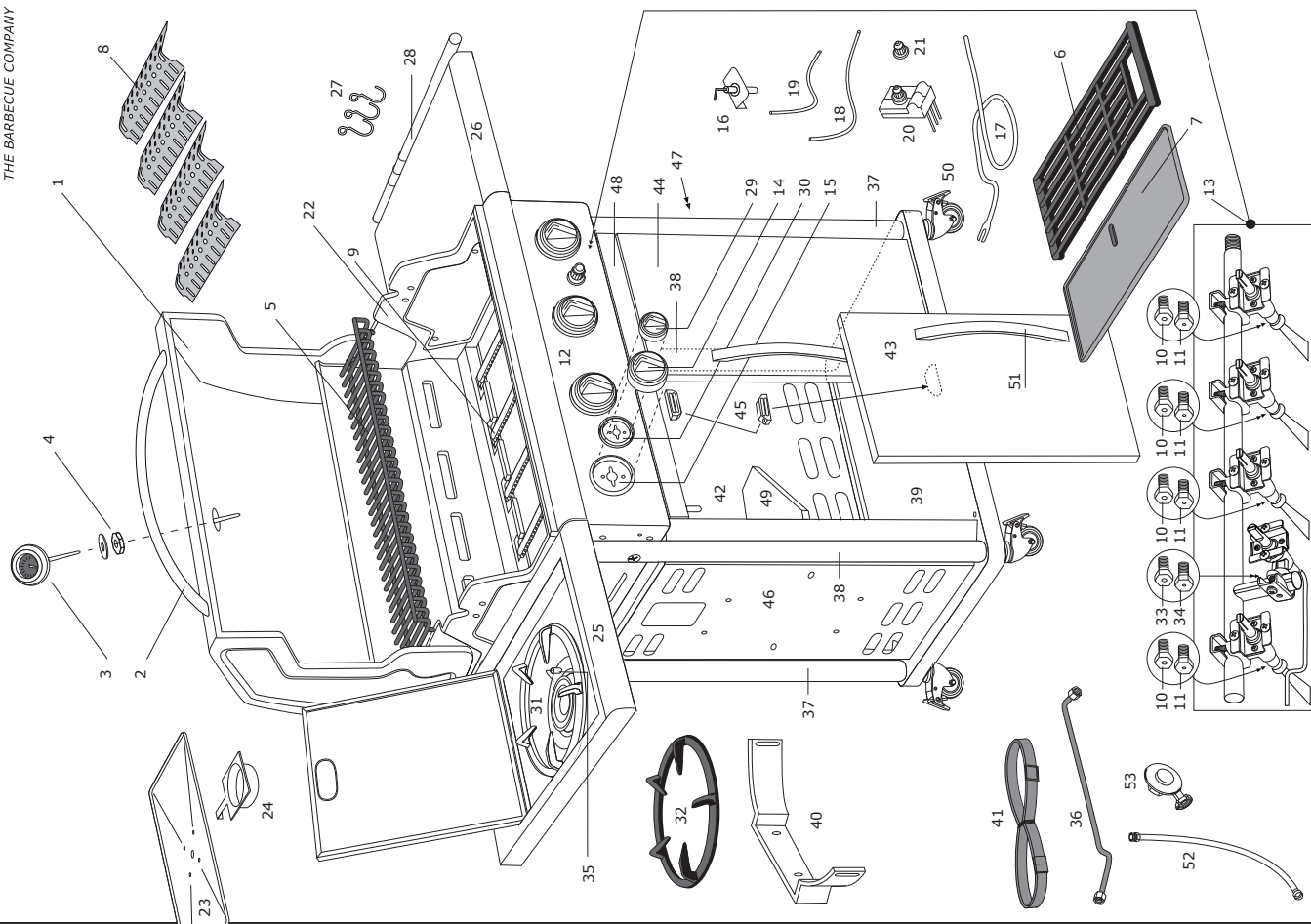

# PERTH

B	Pos.	Art. Nr.	Lid	Description	Deckel	Beschreibung
B1	18.370.95		Protection washer lid handle		Schutz-Unteriagscheibe	Deckelgriff
B2	18.370.76		Teflonwasher		U-Scheibe Teflon	
B3	18.371.08		Screw-cup-washer		Schrauben-Schalen-Unteriagscheibe	
B4	18.370.04		Screw		Schraube	

C	Pos.	Art. Nr.	Piezo electrode side burner	Description	Piezo-Elektrode Seitenbrenner	Beschreibung
C1	18.370.31		Screw		Schraube	
C2	18.370.50		Nut		Mutter	

D	Pos.	Art. Nr.	Piezo electrode & Burner fixation	Description	Piezo-Elektrode & Brenner Befestigung	Beschreibung
D1	18.370.32		Screw		Schraube	
D2	18.371.09		Locking pin		Sicherungsstift	

# PERTH



THE BARBECUE COMPANY

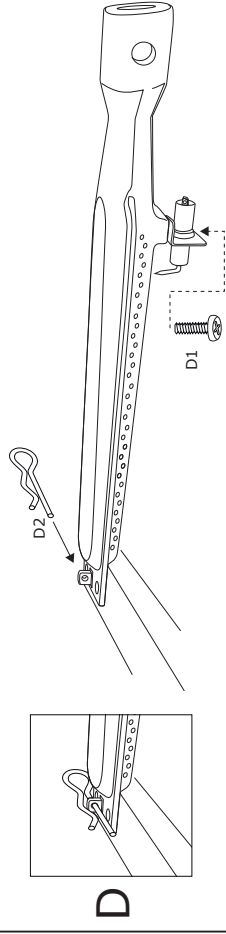
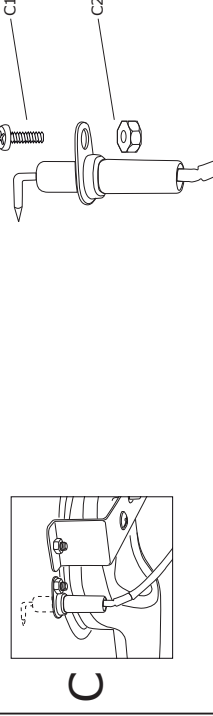
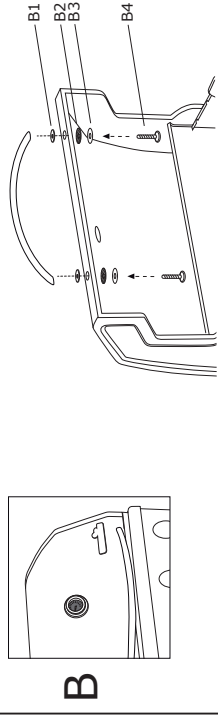

# CITY CHARCOAL 420

## Spare Parts

## Ersatzteil-Liste

Pos. Art. Nr.	Description	Beschreibung
1	18.355.38 Lid black	Deckel schwarz
2	18.360.16 Lid handle	Deckelgriff
3	18.331.05 Upper Vent Disc with handle	Ventilationsschieber oben
4	18.332.61 Cooking grid	Grillrost
5	18.330.86 Charcoal grate	Kohlenrost
6	18.331.66 Grease collector pan	Fettauffangschale
7	18.331.60 Funnel	Trichter
8	18.355.34 Bowl black	Kugel schwarz
9	18.331.06 Lower Vent Disc with handle	Ventilationsschieber unten 420
10	18.330.82 Ash Catcher black	Aschenschale schwarz
11	18.331.62 Bowl fixation black	Kugelhalterung schwarz
12	18.331.63 Legs upper part black	Bein Oberteil schwarz
13	18.331.64 Stabilisation black	Stabilisation schwarz
14	18.331.65 Legs lower part black	Bein Unterteil schwarz
15	18.379.13 Hardware set	Schrauben set

### Attention

Please write your serial number on the backside of the manual for future reference. You will find the number on the data plate attached to the trolley or the bottom plate depending on the grill model. OUTDOORCHEF can only supply spare parts and honour warranty returns when the serial number is available.

### Achtung

Bitte notieren Sie auf der Rückseite Ihrer Gebrauchsanweisung die Serien-Nummer. Je nach Grillmodell finden Sie die Nummer auf dem Datensticker, welcher sich entweder am Grillgestell oder auf der Bodenplatte befindet. OUTDOORCHEF kann Garantie und Ersatzteilieferungen nur mit der Serien-Nummer bearbeiten.

# CITY CHARCOAL 420



THE BARBECUE COMPANY

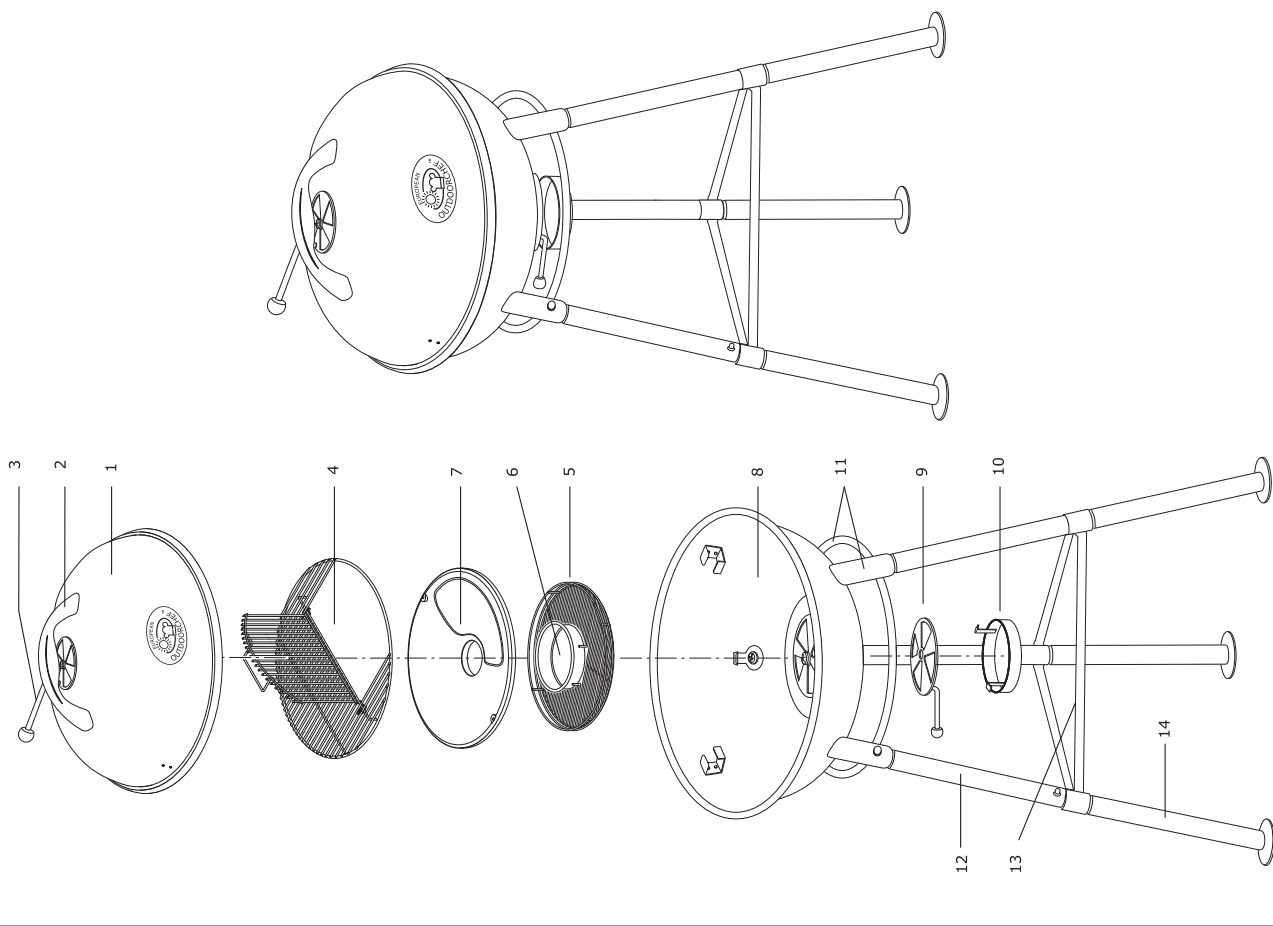

# CITY CHARCOAL 420



THE BARBECUE COMPANY

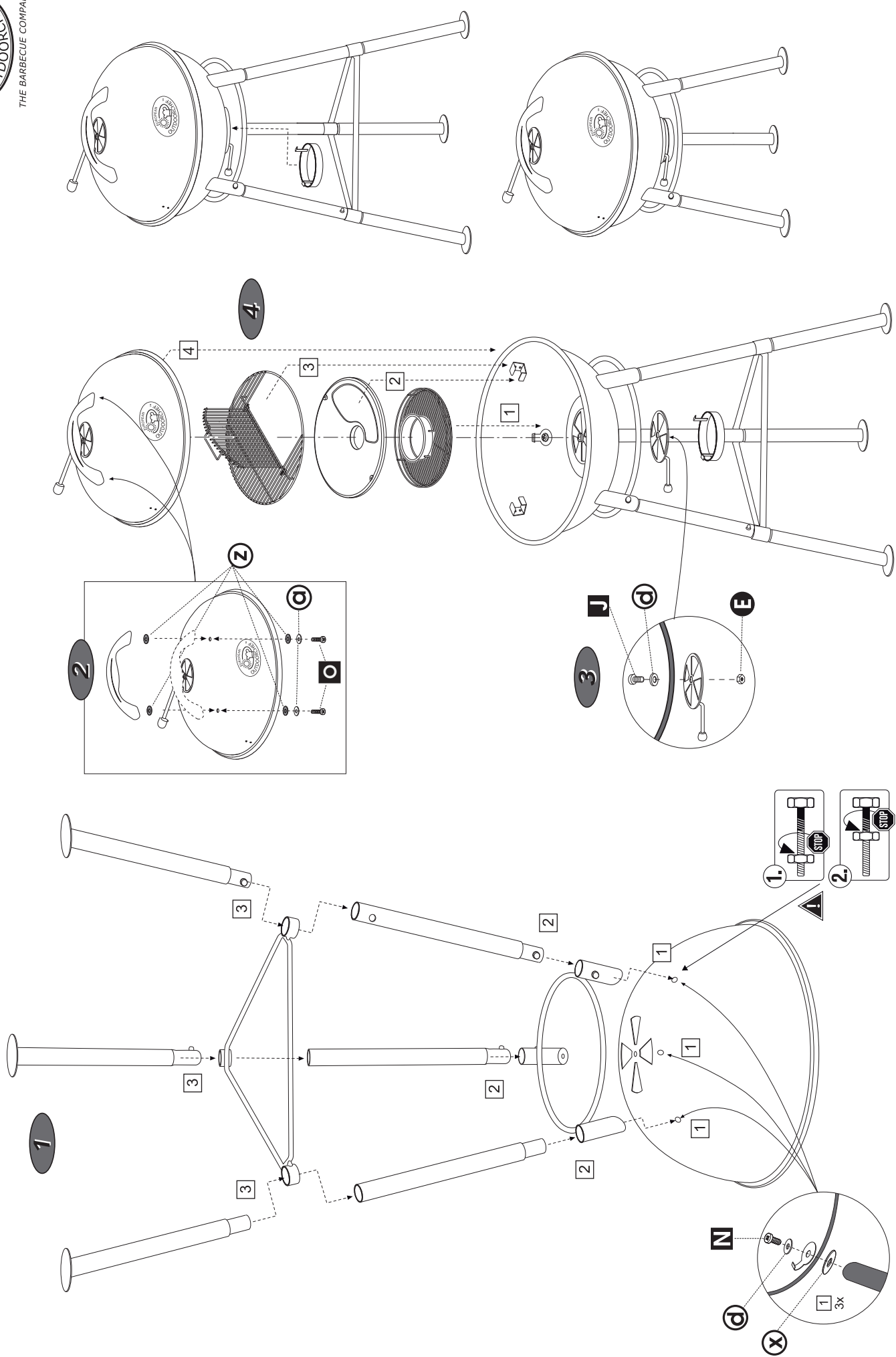

3

2



# Classic Charcoal 570

## Spare Parts

## Ersatzteil-Liste

Pos. Art. Nr.	Description	Beschreibung	
1	18.355.43	Lid black LH	Deckel schwarz LH
2	18.332.37	Lid handle titan-silver	Deckelgriff titan-silber
3	18.850.13	Heat indicator °C/°F	Temperatur Anzeiger °C/°F
4	18.850.18	Frame for heat indicator	Rahmen zu Temperaturanzeiger
5	18.850.12	Heat indicator-Nut	Temperaturanzeiger-Befestigungsmutter
6	18.331.20	Upper vent disc with handle	Ventilationschieber oben mit Griff
7	18.322.21	Lid Hinge titan-silver complete	Deckelscharnier titan-silber Komplet
8	18.360.31	Upper lid hinge cover	Deckelscharnier-Abdeckung oben
9	18.360.32	Lower lid hinge cover	Deckelscharnier-Abdeckung unten
10	18.332.47	Cooking grid	Grillrost
11	18.330.03	Funnel	Trichter
12	18.330.04	Grease collector pan	Fettauffangschale
13	18.330.06	Charcoal grate	Kohlenrost
14	18.330.07	Booster grate	Anzünderost
15	18.355.24	Bowl black LH	Kugel schwarz LH
16	18.332.56	Lower vent disc with handle	Ventilationschieber unten mit Griff
17	18.332.55	Ash Catcher	Aschenbehälter
18	18.332.18	X-Module titan-silver	X-Module titan-silber
19	18.332.19	Trolley front bottom right titan-silver	Fahrgestell vorne unten rechts titan-silber
20	18.332.25	Trolley front bottom left titan-silver	Fahrgestell vorne unten left titan-silber
21	18.332.20	Trolley front top titan-silver	Fahrgestell vorne oben titan-silber
22	18.332.21	Trolley wheel side bottom titan-silver	Fahrgestell Radseite unten titan-silber
23	18.332.22	Trolley wheel side top titan-silver	Fahrgestell Radseite oben titan-silber
24	18.332.23	Axle titan-silver	Radachse titan-silber
25	18.332.24	Front bar titan-silver	Frontstrebe titan-silber
26	18.310.22	Side table black	Seitentablar schwarz
27	18.330.48	Tool holder	Besteck-Halter
28	18.310.20	Bottom shelf black	Bodenrost schwarz
29	18.365.08	Wheel	Rad
30	18.365.11	End Cap	Abschlusskappe
18.379.14	Hardware set	Schrauben set	

### Attention

Please write your serial number on the backside of the manual for future reference. You will find the number on the data plate attached to the trolley or the bottom plate depending on the grill model. OUTDOORCHEF can only supply spare parts and honour warranty returns when the serial number is available.

### Achtung

Bitte notieren Sie auf der Rückseite Ihrer Gebrauchsanweisung die Serien-Nummer. Je nach Grillmodell finden Sie die Nummer auf dem Datensticker, welcher sich entweder am Grillgestell oder auf der Bodenplatte befindet. OUTDOORCHEF kann Garantie und Ersatzteilieferungen nur mit der Serien-Nummer bearbeiten.

# Classic Charcoal 570



THE BARBECUE COMPANY

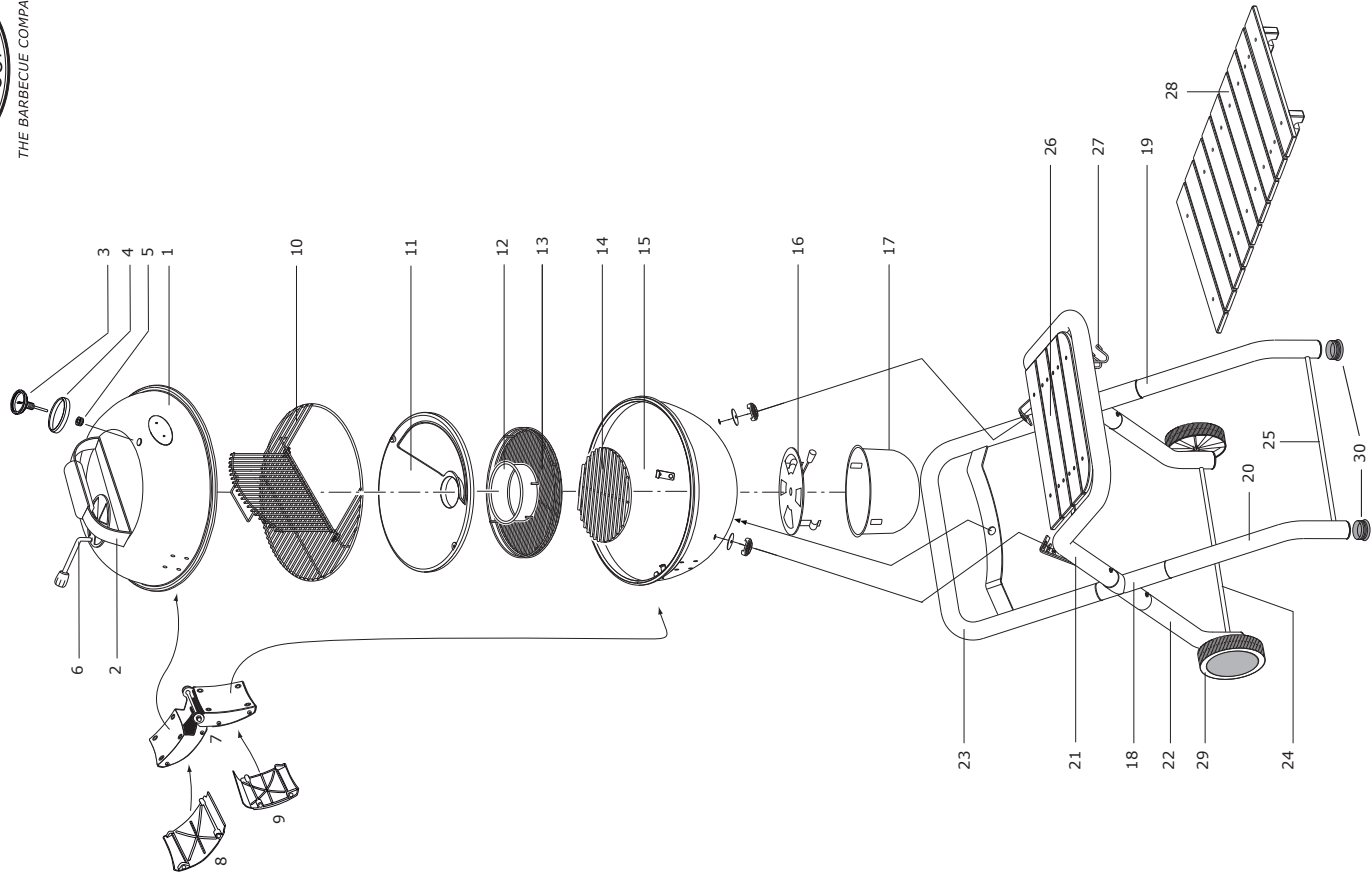

# Classic Charcoal 570

B	Pos.	Art. Nr.	Description	Lid	Description
	B1	18.370.92	Protection washer lid handle	B1	Deckel
	B2	18.370.76	Teflonwasher	B2	Beschreibung
	B3	18.370.63	Washer	B3	Schutz-Unterlagscheibe
	B4	18.370.43	Nut	B4	Deckelgriff

C	Pos.	Art. Nr.	Description	Lid Hinge	Description
	C1	18.332.27	Lid hinge axle	C1	Deckelscharnier
	C2	18.370.40	Dome Nut	C2	Beschreibung
	C3	18.370.63	Washer	C3	Deckelscharnierachse
	C4	18.370.76	Teflonwasher	C4	Hutmutter
	C5	18.370.28	Lid hinge cover screw	C5	U-Scheibe

E	Pos.	Art. Nr.	Description	Bowl	Description
	E1	18.370.10	Screw	E1	Kugel
	E2	18.370.63	Washer	E2	Beschreibung
	E3	18.370.78	Aluminiumwasher	E3	Schraube
	E4	18.370.79	Protection washer bowl	E4	U-Scheibe
	E5	18.370.68	Washer	E5	U-Scheibe Aluminium
	E6	18.370.44	Wing nut	E6	Schutz-Unterlagscheibe

G	Pos.	Art. Nr.	Description	Bottom shelf	Description
	G1	18.371.05	Wood screw	G1	Bodenrost

# Classic Charcoal 570



THE BARBECUE COMPANY

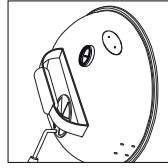

B

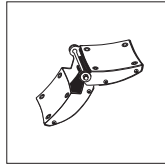

C

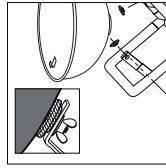

E

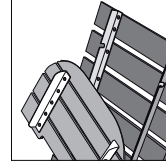

G

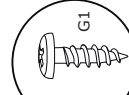
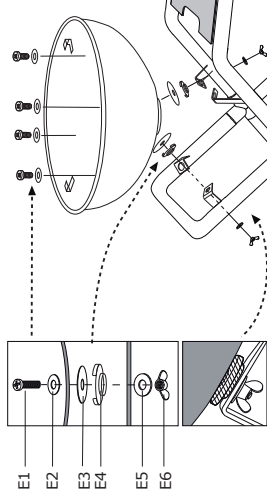
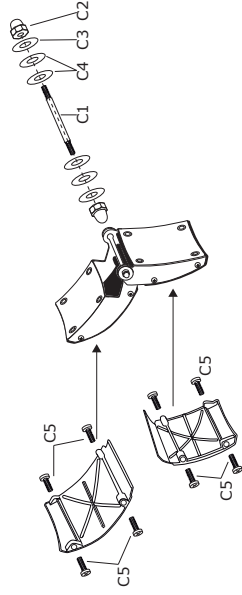

# Easy Charcoal 480

## Spare Parts

## Ersatzteil-Liste

Pos. Art. Nr.	Description	Beschreibung
1	18.355.45 Lid black	Deckel schwarz
2	18.332.28 Lid handle titan-silver	Deckelgriff titan-silber
3	18.850.13 Heat indicator °C/°F	Temperatur Anzeiger °C/°F
4	18.850.12 Heat indicator-Nut	Temperaturanzeiger-Befestigungsmutter
5	18.331.05 Upper Vent Disc with handle	Ventilationsschieber oben mit Griff
6	18.332.57 Cooking grid	Grillrost
7	18.330.02 Funnel	Trichter
8	18.330.04 Grease collector pan	Fettauffangschale
9	18.330.05 Charcoal grate	Kohlenrost
10	18.330.07 Booster grate	Anzünderost
11	18.355.48 Bowl black	Kugel schwarz
12	18.330.46 Tool holder	Besteck Halter
13	18.332.56 Lower Vent disc with handle	Ventilationsschieber unten mit Griff
14	18.332.55 Ash Catcher	Aschenschale
15	18.332.38 Legs upper parts rear titan-silver	Beine Oberhälfte hinten titan-silber
16	18.332.39 Leg upper part front titan-silver	Bein Oberhälfte vorne titan-silber
17	18.360.33 End cap upper part	Abschlusskappe oberer Teil
18	18.332.40 Leg lower part rear right titan-silver	Bein Unterhälfte hinten rechts titan-silber
19	18.332.41 Leg lower part rear left titan-silver	Bein Unterhälfte hinten links titan-silber
20	18.332.58 Leg lower part front titan-silver	Bein Unterhälfte vorne titan-silber
21	18.365.03 End cap under part	Abschlusskappe unterer Teil
22	18.332.59 Triangle titan-silver	Dreieck titan-silber
23	18.332.60 Bottom shelf	Bodenrost
24	18.332.01 Carry handle titan-silver	Handgriff titan-silber
25	18.365.08 Wheel	Rad
		Hardware set

### Attention

Please write your serial number on the backside of the manual for future reference. You will find the number on the data plate attached to the trolley or the bottom plate depending on the grill model. OUTDOORCHEF can only supply spare parts and honour warranty returns when the serial number is available.

### Achtung

Bitte notieren Sie auf der Rückseite Ihrer Gebrauchsanweisung die Serien-Nummer. Sie nach Grillmodell finden Sie die Nummer auf dem Datensticker, welcher sich entweder am Grillgestell oder auf der Bodenplatte befindet. OUTDOORCHEF kann Garantie und Ersatzteil-lieferungen nur mit der Serien-Nummer bearbeiten.

# Easy Charcoal 480



THE BARBECUE COMPANY

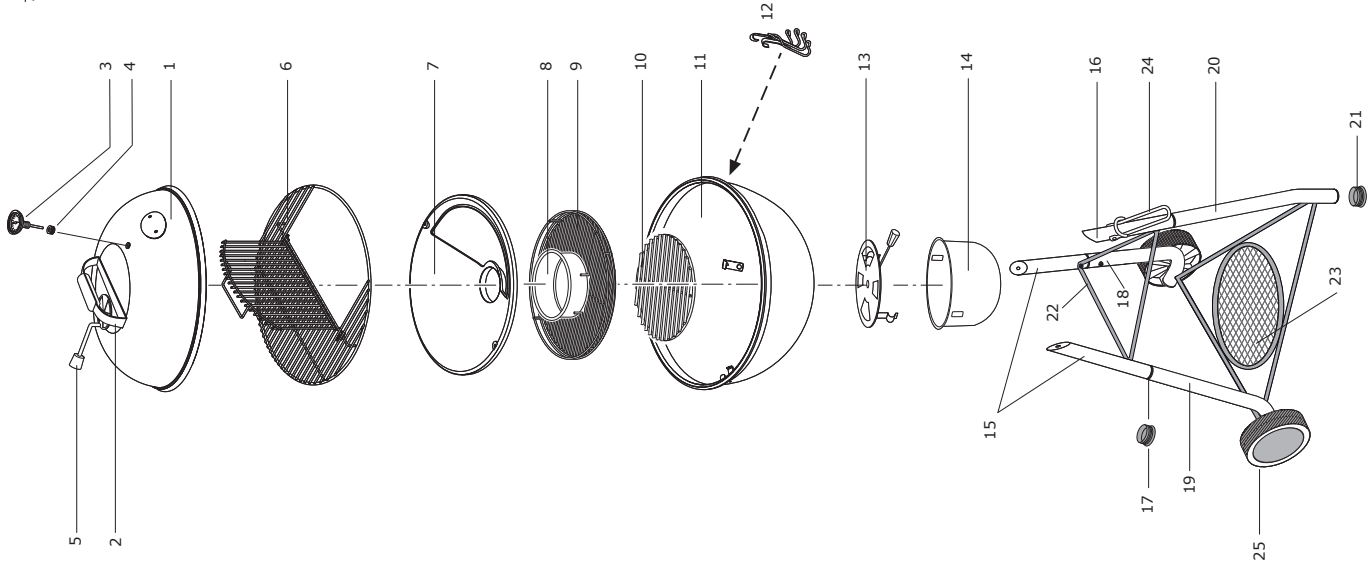

# Easy Charcoal 480

B	Lid	Description
B1	18.370.92	Protection washer lid handle
B2	18.370.76	Teflonwasher
B3	18.370.63	Washer
B4	18.370.43	Nut

Deckel	Beschreibung
U-Scheibe	Teflon
U-Scheibe	
Mutter	

# Easy Charcoal 480

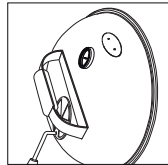

**B**

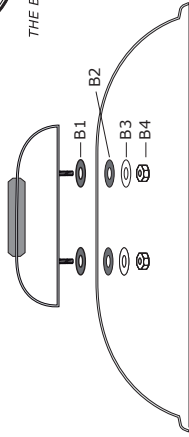

THE BARBECUE COMPANY



# Easy Charcoal 570

## Spare Parts

## Ersatzteil-Liste

Pos. Art. Nr.	Description	Beschreibung
1	18.355.44 Lid black	Deckel schwarz
2	18.332.37 Lid handle titan-silver	Deckelgriff titan-silber
3	18.850.13 Heat indicator °C/°F	Thermomètre °C/°F
4	18.850.18 Frame for heat indicator	Rahmen zu Temperaturanzeiger
5	18.850.12 Heat indicator-Nut	Temperaturanzeiger-Befestigungsmutter
6	18.331.20 Upper Vent Disc with handle	Ventilationsschieber oben mit Griff
7	18.332.47 Cooking grid	Grillrost
8	18.330.03 Funnel	Trichter
9	18.330.04 Grease collector pan	Fettauffangschale
10	18.330.06 Charcoal grate	Kohlenrost
11	18.330.07 Booster grate	Anzünderost
12	18.355.47 Bowl black	Kugel schwarz
13	18.330.47 Tool holder	Besteck-Halter
14	18.332.56 Lower vent disc with handle	Ventilationsschieber unten mit Griff
15	18.332.55 Ash Catcher	Aschenschale
16	18.332.50 Legs upper parts rear titan-silver	Beine Oberhälften hinten titan-silber
17	18.332.51 Leg upper part front titan-silver	Bein Oberhälfte vorne titan-silber
18	18.365.10 End cap upper part	Abschlusskappe oberer Teil
19	18.332.52 Leg lower part rear right titan-silver	Bein Unterhälfte hinten rechts titan-silber
20	18.332.53 Leg lower part rear left titan-silver	Bein Unterhälfte hinten links titan-silber
21	18.332.54 Leg lower part front titan-silver	Bein Unterhälfte vorne titan-silber
22	18.365.04 End cap under part	Abschlusskappe unterer Teil
23	18.332.49 Triangle titan-silver	Dreieck titan-silber
24	18.332.48 Bottom shelf	Bodenrost
25	18.332.10 Carry handle titan-silver	Handgriff titan-silber
26	Deckelhacken	
27	18.365.08 Wheel	Rad
	18.379.09 Hardware set	Schrauben set

### Attention

Please write your serial number on the backside of the manual for future reference. You will find the number on the data plate attached to the trolley or the bottom plate depending on the grill model. OUTDOORCHEF can only supply spare parts and honour warranty returns when the serial number is available.

### Achtung

Bitte notieren Sie auf der Rückseite Ihrer Gebrauchsanweisung die Serien-Nummer. Sie nach Grillmodell finden Sie die Nummer auf dem Datensticker, welcher sich entweder am Grillgestell oder auf der Bodenplatte befindet. OUTDOORCHEF kann Garantie und Ersatzteil-lieferungen nur mit der Serien-Nummer bearbeiten.

# Easy Charcoal 570



THE BARBECUE COMPANY

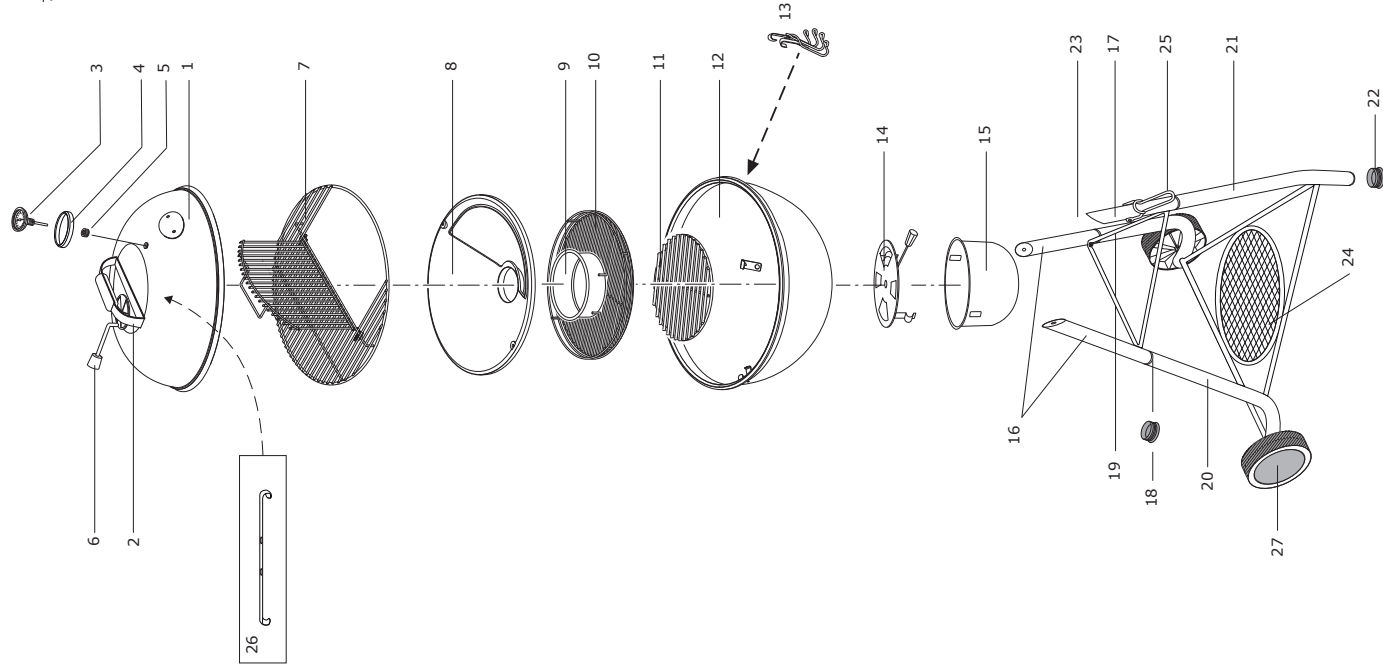



# Easy Charcoal 570

B	Lid	Deckel	
Pos.	Art. Nr.	Description	Beschreibung
B1	18.370.92	Protection washer lid handle	Schutz-Unterlagscheibe Deckelgriff
B2	18.370.76	Teflonwasher	U-Scheibe Teflon
B3	18.332.44	Lid hook	Deckelhacken
B4	18.370.43	Nut	Mutter

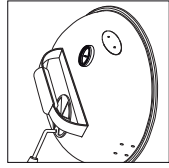

**B**

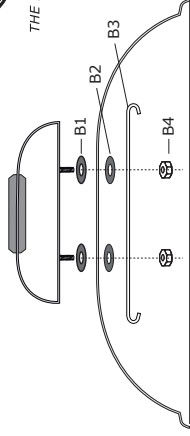

THE BARBECUE COMPANY



# Easy Charcoal 570



# Rover 480

## Spare Parts

Pos. Art. Nr.	Description	Beschreibung	
1	18.355.42	Lid black	Deckel schwarz
2	18.332.28	Lid handle titan-silver	Deckegriff titan-silber
3	18.850.13	Heat indicator °C/°F	Temperatur Anzeiger °C/°F
4	18.850.12	Heat indicator-Nut	Temperaturanzeiger-Befestigungsmutter
5	18.331.05	Upper Vent Disc with handle	Ventilationsschieber oben mit Griff
6	18.322.20	Lid hinge titan-silver complete	Deckelscharnier titan-silber Komplett
7	18.360.29	Upper lid hinge cover	Deckelscharnier-Abdeckung oben
8	18.360.30	Lower lid hinge cover	Deckelscharnier-Abdeckung unten
9	18.332.57	Cooking grid	Grillrost
10	18.330.02	Funnel	Trichter
11	18.330.04	Grease collector pan	Feltaufangschale
12	18.330.05	Charcoal grate	Kohlenrost
13	18.330.07	Booster grate	Anzünderost
14	18.355.46	Bowl black	Kugel schwarz
15	18.330.46	Tool holder	Besteck Halter
16	18.332.56	Lower Vent Disc with handle	Ventilationsschieber unten mit Griff
17	18.332.55	Ash Catcher	Aschenschale
18	18.332.63	Legs upper parts titan-silver	Beine Oberenteil titan-silber
19	18.332.68	Leg lower part rear right titan-silver	Bein Unterteil hinten rechts titan-silber
20	18.332.69	Leg lower part rear left titan-silver	Bein Unterteil hinten links titan-silber
21	18.332.70	Leg lower part front titan-silver	Bein Unterteil vorne titan-silber
22	18.365.03	End cap	Abschlusskappe
23	18.332.71	Bottom plate titan-silver	Bodenplatte titan-silber
24	18.331.93	Axle titan-silver	Radachse titan-silber
25	18.365.08	Wheel	Rad
18.379.12	Hardware set	Schrauben Set	

### Attention

Please write your serial number on the backside of the manual for future reference. You will find the number on the data plate attached to the trolley or the bottom plate depending on the grill model. OUTDOORCHEF can only supply spare parts and honour warranty returns when the serial number is available.

### Achtung

Bitte notieren Sie auf der Rückseite Ihrer Gebrauchsanweisung die Serien-Nummer. Je nach Grillmodell finden Sie die Nummer auf dem Datensticker, welcher sich entweder am Grillgestell oder auf der Bodenplatte befindet. OUTDOORCHEF kann Garantie und Ersatzteil-lieferungen nur mit der Serien-Nummer bearbeiten.

# Rover 480



THE BARBECUE COMPANY

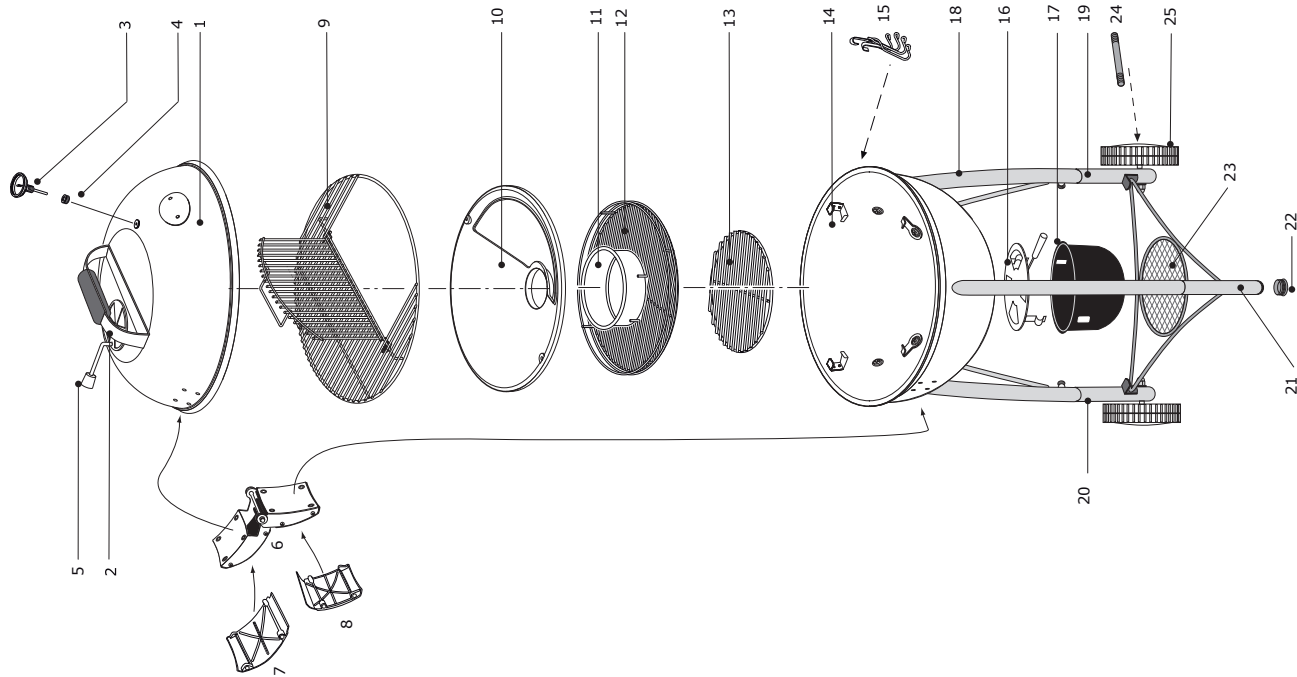

# ROVER 480

B	Lid	Deckel
Pos.	Art. Nr.	Description
B1	18.370.92	Protection washer lid handle
B2	18.370.76	Teflonwasher
B3	18.370.63	Washer
B4	18.370.43	Nut

C	Lid Hinge	Deckelscharnier
Pos.	Art. Nr.	Description
C1	18.332.42	Lid hinge axle
C2	18.370.40	Dome Nut
C3	18.370.63	Washer
C4	18.370.76	Teflonwasher
C5	18.370.28	Lid hinge cover screw

E	Bowl	Kugel
Pos.	Art. Nr.	Description
E1	18.370.07	Screw
E2	18.370.63	Washer
E3	18.370.76	Teflonwasher
E4	18.370.72	Protection washer bowl
E5	18.370.43	Nut

# ROVER 480

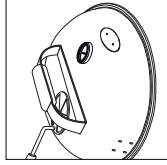

**B**

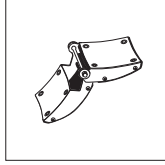

**C**

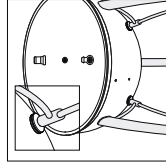

**E**



THE BARBECUE COMPANY

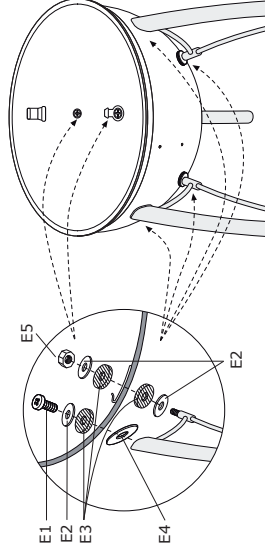
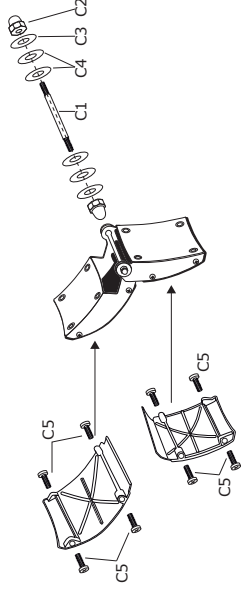

# Rover 570

## Spare Parts

Pos. Art. Nr.	Description	Beschreibung
1 18.355.43	Lid black LH	Deckel schwarz LH
2 18.332.37	Lid handle titan-silver	Deckelgriff titan-silber
3 18.850.13	Heat indicator °C/°F	Thermomètre °C/°F
4 18.850.18	Frame for heat indicator	Rahmen zu Temperaturanzeiger
5 18.850.12	Heat indicator-Nut	Temperaturanzeiger-Befestigungsmutter
6 18.331.20	Upper Vent-Disc with handle	Ventilationschieber oben mit Griff
7 18.322.21	Lid Hinge titan-silver complete	Deckelscharnier titan-silber Komplett
8 18.360.31	Upper lid hinge cover	Deckelscharnier-Abdeckung oben
9 18.360.32	Lower lid hinge cover	Deckelscharnier-Abdeckung unten
10 18.332.47	Cooking grid	Grillrost
11 18.330.03	Funnel	Trichter
12 18.330.04	Grease collector pan	Fettauffangschale
13 18.330.06	Charcoal grate	Kohlenrost
14 18.330.07	Booster grate	Anzünderost
15 18.355.39	Bowl black	Kugel schwarz
16 18.330.47	Tool holder	Besteck-Halter
17 18.332.56	Lower vent disc with handle	Ventilationschieber unten mit Griff
18 18.332.55	Ash Catcher	Aschenschale
19 18.332.62	Legs upper part titan-silver	Beine Oberteil titan-silber
20 18.332.65	Leg lower part rear left titan-silver	Bein Unterteil hinten links titan-silber
21 18.332.66	Leg lower part rear right titan-silver	Bein Unterteil hinten rechts titan-silber
22 18.332.67	Leg lower part front titan-silver	Bein Unterteil vorne titan-silber
23 18.332.64	Bottom shelf titan-silver	Bodenplatte titan-silber
24 18.332.16	Axle titan-silver	Radachse titan-silber
25 18.365.08	Wheel	Rad
26 18.365.02	Caster with brake	Lenkrolle mit Bremse
18.379.10	Hardware set	Schrauben set

### Attention

Please write your serial number on the backside of the manual for future reference. You will find the number on the data plate attached to the trolley or the bottom plate depending on the grill model. OUTDOORCHEF can only supply spare parts and honour warranty returns when the serial number is available.

### Achtung

Bitte notieren Sie auf der Rückseite Ihrer Gebrauchsanweisung die Serien-Nummer. Je nach Grillmodell finden Sie die Nummer auf dem Datensticker, welcher sich entweder am Grillgestell oder auf der Bodenplatte befindet. OUTDOORCHEF kann Garantie und Ersatzteil-lieferungen nur mit der Serien-Nummer bearbeiten.

# Rover 570



THE BARBECUE COMPANY

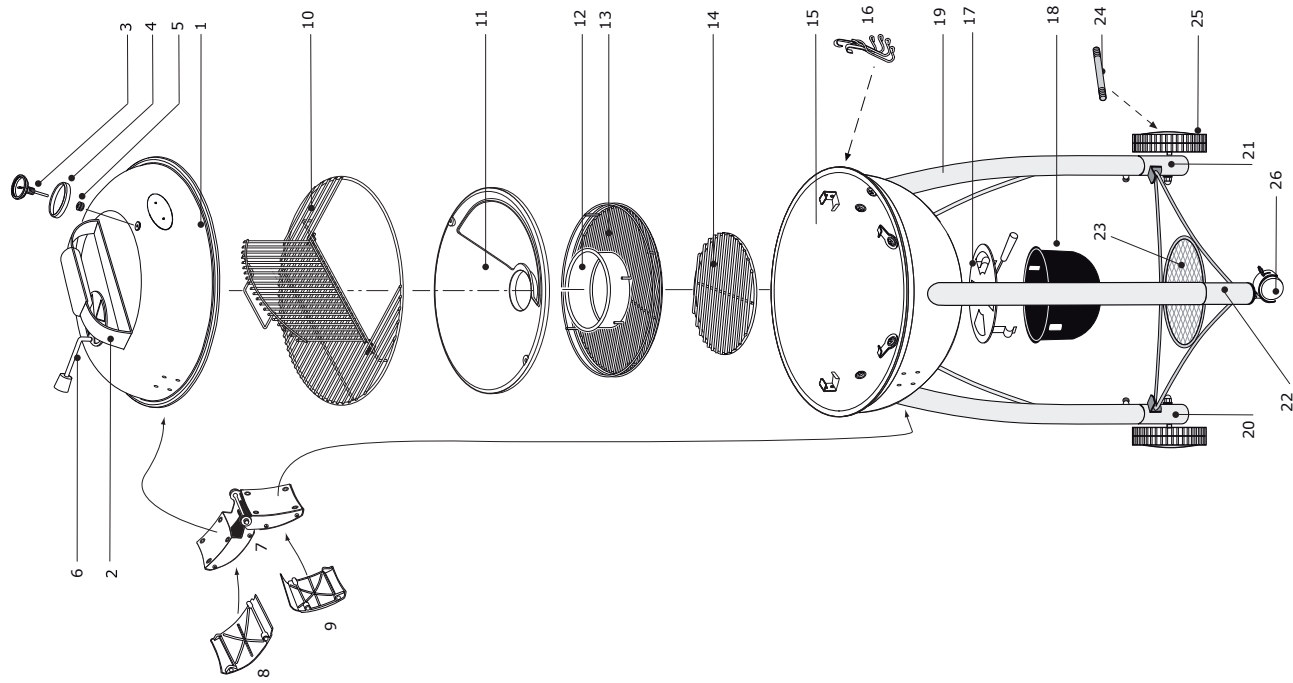

# ROVER 570

B	Lid	Deckel
Pos.	Art. Nr.	Description
B1	18.370.92	Protection washer lid handle
B2	18.370.76	Teflonwasher
B3	18.370.63	U-Scheibe
B4	18.370.43	Nut

C	Lid Hinge	Deckelscharnier
Pos.	Art. Nr.	Description
C1	18.332.27	Lid hinge axle
C2	18.370.40	Dome Nut
C3	18.370.63	Washer
C4	18.370.76	Teflonwasher
C5	18.370.28	Lid hinge cover screw

E	Bowl	Kugel
Pos.	Art. Nr.	Description
E1	18.370.07	Screw
E2	18.370.63	Washer
E3	18.370.76	Teflonwasher
E4	18.370.84	Protection washer bowl
E5	18.370.43	Nut

# ROVER 570

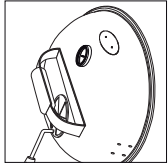

**B**

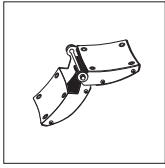

**C**

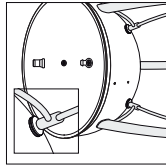

**E**

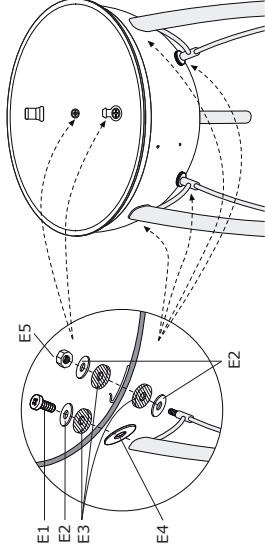
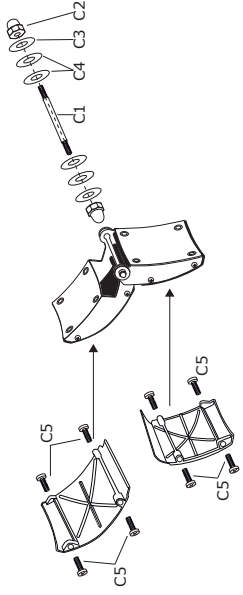
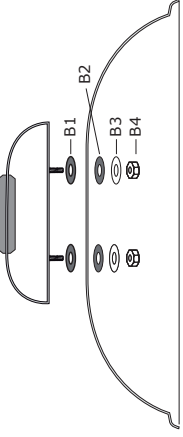



# City Electro 420

## Spare Parts

Pos.	Art. Nr.	Description	Beschreibung
1	18.510.00	Lid black	Deckel schwarz
2	18.530.00	Lid handle	Deckelgriff
3	18.550.00	Cooking grid	Grillrost
4	18.550.01	Heat reflector	Hitzreflektor
*5	18.211.53	Heat reflector foil set of 3 pieces	Hitzreflektor-Folie Set von 3 Stück
6	18.540.05	Heat controller with power cord plug E&F	Temperaturregler mit Netzkabel Stecker E&F
6	18.540.06	Heat controller with power cord plug J	Temperaturregler mit Netzkabel Stecker J
6	18.540.07	Heat controller with power cord plug BS	Temperaturregler mit Netzkabel Stecker BS
6	18.540.08	Heat controller with power cord plug AU	Temperaturregler mit Netzkabel Stecker AU
7	18.510.01	Bowl black	Kugel schwarz
8	18.550.02	Drip pan	Fettauffangschale
9	18.540.09	Heating element	Heizelement
10	18.599.01	Middle shelve	Zwischentablar
11	18.550.03	Bowl fixation	Kugelhalterung
12	18.550.04	Legs upper part	Bein Oberteil
13	18.550.05	Stabilisation	Stabilisation
14	18.550.06	Legs lower part	Bein Unterteil
15	18.332.26	Support ring	Support Ring

B	Lid	Deckel
Pos.	Art. Nr.	Description
B1	18.370.27	Screw
B2	18.371.04	Spring washer

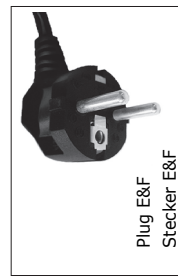

Plug E&F  
Stecker E&F



Plug J  
Stecker J

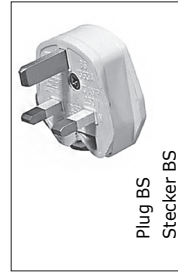

Plug BS  
Stecker BS



\* Die Hitzreflektor - Folie ist als Zubehör erhältlich.  
The heat reflector - foil is available as accessories.

### Attention

Please write your serial number on the backside of the manual for future reference. You will find the number on the data plate attached to the trolley or the bottom plate depending on the grill model. OUTDOORCHEF can only supply spare parts and honour warranty returns when the serial number is available.

### Achtung

Bitte notieren Sie auf der Rückseite Ihrer Gebrauchsanweisung die Serien-Nummer. Je nach Grillmodell finden Sie die Nummer auf dem Datensticker, welcher sich entweder am Grillgestell oder auf der Bodenplatte befindet. OUTDOORCHEF kann Garantie und Ersatzteil-lieferungen nur mit der Serien-Nummer bearbeiten.



www.outdoorchef.com

European Outdoor Chef operates a policy of continuous product development and improvement. As such we reserve the right to alter product design and or technical specification without giving any prior notice.

# City Electro 420



THE BARBECUE COMPANY

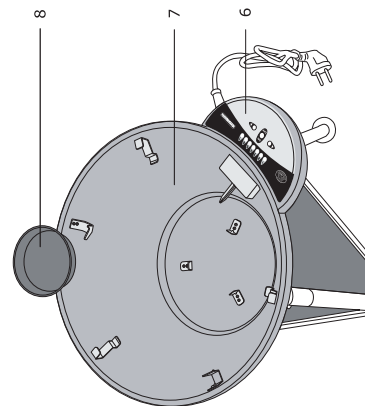
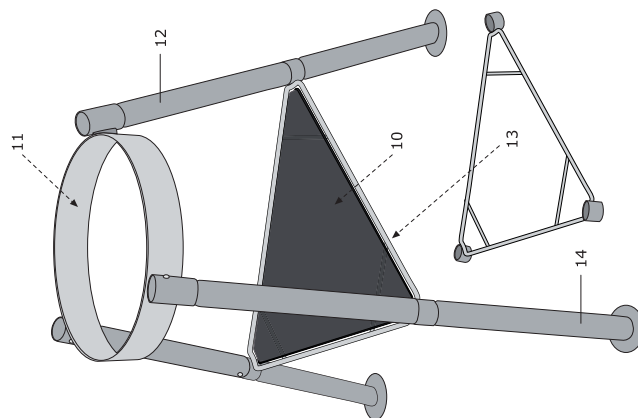
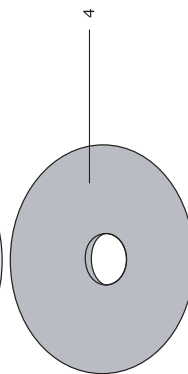
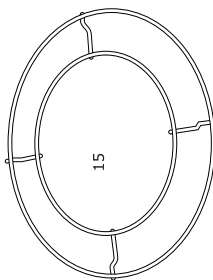
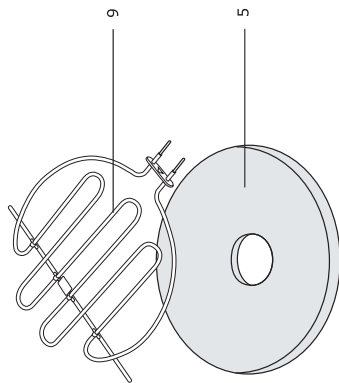
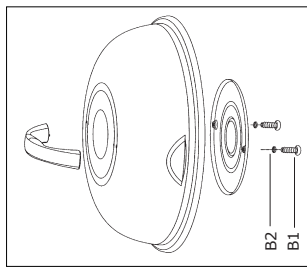
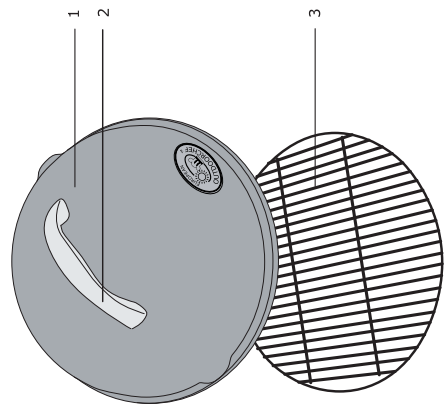

## Index

- A** Abdeckhauben..... S. 30, 33, 34  
 Abdeckhaube City Gas..... S. 28  
 Abdeckhaube Gasflasche..... S. 30  
 Abdeckkorb Rattan ..... S. 30  
 Alu-Schutzfolie ..... S. 27  
 Ambri schwarz ..... S. 8, 40, 41  
 Ambri ruby ..... S. 8, 40, 41  
 Aromapfanne Ø 23cm..... S. 25  
 Ascona schwarz ..... S. 9, 42, 43  
 Ascona blau..... S. 9, 42, 43  
 Ascona ruby ..... S. 9, 42, 43  
 Auckland..... S. 18, 62, 63  
 Australian Line..... S. 14-18
- B** Base Line..... S. 6, 7  
 Back- und Kuchenblech ..... S. 24  
 BBQ Cleaner..... S. 31  
 Beschwipstes Huhn (Rost)..... S. 24  
 Besteckset „Royal“..... S. 29  
 Bratenkorb-Set..... S. 16  
 Bürste „Fredy“ ..... S. 31  
 Bürste „Lucy“..... S. 31  
 Bürste „Silvy“..... S. 31  
 Bürste „Silvy“ Ersatzköpfe .... S. 31
- C** Cairns..... S. 15, 64, 65  
 Canberra ..... S. 16, 66, 67  
 Charcoal Line ..... S. 22,23  
 City Charcoal ..... S. 22, 72, 73  
 City Elektro ..... S. 19, 84  
 City Tripod schwarz ..... S. 6, 44, 45  
 City Tripod vanille..... S. 6, 44, 45  
 Classic Charcoal..... S. 23, 74, 75  
 Classic Line..... S. 8-11  
 Cubic Line..... S. 12,13  
 Culinary Entertainer ..... S. 26
- D** Deckelhalter 480/570 ..... S. 26  
 Delta ..... S. 7, 46, 47  
 Der Outdoorchef..... S. 36
- E** Easy Charcoal 480 ..... S. 22, 76, 77  
 Easy Charcoal 570 ..... S. 22, 78, 79  
 Eigene Notizen ..... S. 87
- G** Geneva ..... S. 11, 48, 49  
 Gourmet Check..... S. 30  
 Gourmet Set ..... S. 24  
 Gourmet-Set City ..... S. 27  
 Gourmet Spatula ..... S. 29  
 Grillrost Ø 54cm (570er)..... S. 32  
 Grillrost Ø 45cm (480er)..... S. 32  
 Grillspass Heute..... S. 26  
 Gussplatte Plancha Ø 39cm.... S. 25  
 Gussplatte Plancha Ø 33cm.... S. 27  
 Gusseisenpfanne Ø 38cm ..... S. 25  
 Gusseisenplatte 44x24,5cm ..... S. 25  
 Gusseisenrost Ø 45cm 2-teilig S. 35  
 Gusseisenrost Ø 45cm 1-teilig S. 35  
 Gusseisenrost Ø 54cm 2-teilig S. 35  
 Gusseisenrost Ø 54cm 1-teilig S. 35
- H** Hamilton..... S. 15, 68, 69
- L** Lederhandschuhe Paar L ..... S. 30  
 Lederhandschuhe Paar M ..... S. 30  
 Leon schwarz ..... S. 7, 50, 51  
 Leon vanilla..... S. 7, 50, 51
- M** Montreux ..... S. 10, 52, 53  
 Munich..... S. 12, 55, 55

## Index

- P** Paris Deluxe..... S. 12, 56, 57  
Perth..... S. 17, 70, 71  
Pinzette..... S. 29  
Pizzaschaufel ..... S. 26  
Pizza- und Backblech..... S. 24  
Pizza- und Brotbackstein ..... S. 24  
Pizza- und Brotbackstein City S. 27  
Porto..... S. 6, 58, 59  
Preisliste ..... S. 38, 39
- Q** Quick Lock „Grillzange“ ..... S. 29
- R** Rover 480 ..... S. 23, 80, 81  
Rover 570 LH ..... S. 23, 82, 83
- S** Schlauch- und Regler Sets..... S. 32  
Schneidebrett Bambus..... S. 36  
Schürze „OUTDOORCHEF“ S. 30  
Seitenablage 480 ..... S. 26
- Seitenablage 570 ..... S. 26  
Silikon Handschuh 3-Finger... S. 36  
Silikon Topflappen ..... S. 36  
Systemzubehör ..... S. 24-28
- T** Team ..... S. 2  
Thermometer für Deckel ..... S. 32  
Tragetasche zu City Gas ..... S. 28  
Trichtertechnik Gas ..... S. 4, 5  
Trichtertechnik Kohle..... S. 20, 21
- U** Übersicht Sortiment ..... S. 3  
Universalpfanne..... S. 24  
Universalzubehör..... S. 29-32  
Unterbau zu City Gas..... S. 28
- V** Venezia ..... S. 13, 60, 61
- W** Wok aus Gusseisen Ø 35cm.... S. 25

# Eigene Notizen

---

---

---

---

---

---

---

---

---

---

---

---

---

---

---

---

---

---

---

---

---

---

---

---

---

---

---

---

---



DKB Household Germany GmbH  
Ochsenmattstr. 10

DE - 79618 Rheinfelden  
Tel: +49 (0)7623 74190-0  
Fax: +49 (0)7623 74190-10  
[info@outdoorchef.de](mailto:info@outdoorchef.de)  
[www.outdoorchef.de](http://www.outdoorchef.de)

DKB Household Austria GmbH  
Dückerstraße 15 / Top 2

AT - 1220 Wien  
Tel: +49 7623 74190-16  
Fax: +49 7623 74190-10  
[info@outdoorchef.at](mailto:info@outdoorchef.at)  
[www.outdoorchef.at](http://www.outdoorchef.at)