

Enders®

MONROE PRO

**4 SIKR TURBO
4 SIKR TURBO SHADOW**

de MONTAGEANLEITUNG
en ASSEMBLY INSTRUCTIONS
bg УПЪТВАНЕ ЗА МОНТАЖ
cs MONTÁŽNÍ NÁVOD
da MONTERINGSVEJLEDNING
el ΟΔΗΓΙΕΣ ΣΥΝΑΡΜΟΛΟΓΗΣΗΣ
es INSTRUCCIONES DE MONTAJE
et MONTAÄŽIJUHEND
fi ASENNUSOHJE
fr INSTRUCTIONS DE MONTAGE
hr UPUTE ZA MONTAŽU
hu ÖSSZESZERELÉSI ÚTMUTATÓ
is LEIÐBEININGAR FYRIR SAMSETNINGU

it ISTRUZIONI DI MONTAGGIO
lt MONTAVIMO INSTRUKCIJA
lv MONTĀŽAS INSTRUKCIJA
nb MONTERINGSVEILEDNING
nl MONTAGEHANDLEIDING
pl INSTRUKCJA MONTAŻU
pt INSTRUÇÕES DE MONTAGEM
ro INSTRUCȚIUNI DE ASAMBLARE
sk NÁVOD NA MONTÁŽ
sl NAVODILA ZA SESTAVLJANJE
sv MONTERINGSANVISNING
tr MONTAJ TALIMATI

8362

8366

836221

836233

836633



SICHERHEITSHINWEISE

de



GEFAHR: Lebensgefahr durch Ersticken/Verschlucken. Verpackungsmaterial von Kindern fernhalten und sofort entsorgen. Kleinteile außerhalb von deren Reichweite aufbewahren.

WARNUNG: Trotz sorgfältiger Verarbeitung aller Einzelteile, können einzelne Bauteile scharfkantig sein. Sicherheitshandschuhe tragen, um Schnittverletzungen zu vermeiden.

ACHTUNG: Vor Beginn der Montage alle Verpackungsmaterialien und Schutzfolien von den Einzelteilen entfernen.

ACHTUNG: Den Grill auf einem flachen, ebenen und weichen Untergrund montieren, um Beschädigungen zu vermeiden.

ACHTUNG: Keine Elektrowerkzeuge zur Montage verwenden.

ACHTUNG: Die Garhaube beim Zusammenbau oder Bewegen des Grills stets geschlossen halten.



Das erworbene Modell kann geringfügig von der Darstellung abweichen. Die Montage muss von zwei Personen durchgeführt werden. Achte darauf, dass alle Schrauben festgezogen sind. Kontrolliere in regelmäßigen Abständen den festen Sitz aller Schrauben.

SAFETY INSTRUCTIONS

en



DANGER: Risk of death by suffocation/swallowing. Keep packaging materials away from children and dispose of them immediately. Keep small parts out of their reach

WARNING: Despite careful manufacturing, some components may have sharp edges. Wear protective gloves to avoid cuts.

CAUTION: Remove all packaging materials and protective films from the components before starting assembly.

CAUTION: Assemble the grill on a flat, level, and soft surface to avoid damage.

CAUTION: Do not use power tools for assembly.

CAUTION: Keep the lid closed during assembly or when moving the grill.



The purchased model may differ slightly from the illustration. Assembly must be carried out by two people. Make sure that all screws are tightened securely. Check all screws regularly to ensure they remain tight.

ИНСТРУКЦИИ ЗА БЕЗОПАСНОСТ

bg



ОПАСНОСТ: Смъртоносен риск от задушаване/гълтане. Дръжте опаковъчните материали далеч от деца и ги изхвърлете незабавно. Дръжте малките части далеч от децата.

ПРЕДУПРЕЖДЕНИЕ: Въпреки внимателната обработка, някои части могат да имат остри ръбове. Носете защитни ръкавици, за да избегнете порязвания.

ВНИМАНИЕ: Преди започване на монтажа премахнете всички опаковъчни материали и защитни фолиа от частите.

ВНИМАНИЕ: Монтирайте грила върху равна, равномерна и мека повърхност, за да избегнете повреди.

ВНИМАНИЕ: Не използвайте електроинструменти за монтажа.

ВНИМАНИЕ: Дръжте капака затворен по време на монтажа или преместването на грила.



Закупеният модел може да се различава леко от илюстрацията. Монтажът трябва да се извършва от двама души. Уверете се, че всички винтове са добре затегнати. Редовно проверявайте дали винтовете са здраво закрепени.

BEZPEČNOSTNÍ POKYNY

CS



NEBEZPEČÍ: Nebezpečí udušení nebo spolknutí s rizikem smrti. Uchovávejte obalové materiály mimo dosah dětí a ihned je zlikvidujte. Malé části uchovávejte mimo dosah dětí.

VAROVÁNÍ: Přestože byly všechny části pečlivě vyrobeny, některé mohou mít ostré hrany. Používejte ochranné rukavice, abyste předešli řezným ranám.

POZOR: Před zahájením montáže odstraňte všechny obalové materiály a ochranné fólie z dílů.

POZOR: Gril montujte na rovný, rovnoměrný a měkký povrch, aby nedošlo k poškození.

POZOR: Nepoužívejte elektrické nářadí k montáži.

POZOR: Během montáže nebo přesunu grilu držte víko zavřené.



Zakoupený model se může mírně lišit od zobrazení. Montáž musí provést dvě osoby. Ujistěte se, že všechny šrouby jsou pevně utaženy. Pravidelně kontrolujte pevnost šroubů.

SIKKERHEDSANVISNINGER

da



FARE: Livsfare på grund af kvælning eller indtagelse. Hold emballagematerialer væk fra børn og kasser dem straks. Opbevar små dele uden for børns rækkevidde.

ADVARSEL: På trods af omhyggelig fremstilling kan enkelte dele have skarpe kanter. Brug beskyttelseshandsker for at undgå snitsår.

OBS: Fjern alt emballagemateriale og beskyttelsesfilm fra delene før montering.

OBS: Monter grillen på en flad, jævn og blød overflade for at undgå skader.

OBS: Brug ikke elektriske værktøjer til monteringen.

OBS: Hold låget lukket under montering eller når grillen flyttes.



Den købte model kan afvige lidt fra illustrationen. Monteringen skal udføres af to personer. Sørg for, at alle skruer er spændt godt fast. Kontroller regelmæssigt, at alle skruer stadig sidder fast.

ΟΔΗΓΙΕΣ ΑΣΦΑΛΕΙΑΣ



ΚΙΝΔΥΝΟΣ: Κίνδυνος ασφυξίας/κατάποσης που μπορεί να οδηγήσει σε θάνατο. Κρατήστε τα υλικά συσκευασίας μακριά από τα παιδιά και απορρίψτε τα αμέσως. Κρατήστε μικρά εξαρτήματα μακριά από την πρόσβαση των παιδιών.

ΠΡΟΕΙΔΟΠΟΙΗΣΗ: Παρά την προσεκτική κατασκευή, ορισμένα μέρη μπορεί να έχουν αιχμηρές άκρες. Φορέστε προστατευτικά γάντια για να αποφύγετε κοψίματα.

ΠΡΟΣΟΧΗ: Πριν ξεκινήσετε τη συναρμολόγηση, αφαιρέστε όλα τα υλικά συσκευασίας και τις προστατευτικές μεμβράνες από τα μέρη.

ΠΡΟΣΟΧΗ: Συναρμολογήστε τη σχάρα σε μια επίπεδη, ομαλή και μαλακή επιφάνεια για να αποφύγετε ζημιές.

ΠΡΟΣΟΧΗ: Μην χρησιμοποιείτε ηλεκτρικά εργαλεία για τη συναρμολόγηση.

ΠΡΟΣΟΧΗ: Κρατήστε το καπάκι κλειστό κατά τη συναρμολόγηση ή τη μετακίνηση της σχάρας.



Το αγορασθέν μοντέλο μπορεί να διαφέρει ελαφρώς από την απεικόνιση. Η συναρμολόγηση πρέπει να γίνει από δύο άτομα. Βεβαιωθείτε ότι όλες οι βίδες είναι σφικτά βιδωμένες. Ελέγχετε τακτικά αν οι βίδες παραμένουν στερεωμένες.

INSTRUÇÕES DE SEGURANÇA



PELIGRO: Riesgo de muerte por asfixia o ingestión. Mantenga el material de embalaje fuera del alcance de los niños y deséchelo inmediatamente. Guarde de las piezas pequeñas fuera de su alcance.

ADVERTENCIA: Aunque todas las piezas se han fabricado cuidadosamente, algunas pueden tener bordes afilados. Use guantes de protección para evitar cortes.

PRECAUCIÓN: Antes de comenzar el montaje, retire todos los materiales de embalaje y las láminas protectoras de las piezas.

PRECAUCIÓN: Monte la barbacoa sobre una superficie plana, nivelada y blanda para evitar daños.

PRECAUCIÓN: No utilice herramientas eléctricas para el montaje.

PRECAUCIÓN: Mantenga la tapa cerrada durante el montaje o cuando mueva la barbacoa.



El modelo adquirido puede diferir ligeramente de la ilustración. El montaje debe ser realizado por dos personas. Asegúrese de que todos los tornillos estén bien apretados. Verifique regularmente que los tornillos estén firmes.

OHUTUSJUHISED



OHT: Lämbumisoht ja alla neelamise oht. Hoidke pakendimaterjalid laste eest eemal ja visake kohe ära. Hoidke väikesed osad laste käeulatuses eemal.

HOIATUS: Hoolika tootmise juures võivad mõned detailid olla teravate servadega. Kandke kaitsekindaid, et vältida löikehaavu.

TÄHELEPANU: Enne kokkupaneku alustamist eemaldage kõik pakendimaterjalid ja kaitsekiled osadelt.

TÄHELEPANU: Paigaldage grill tasasele, ühtlasele ja pehmele pinnale, et vältida kahjustusi.

el

TÄHELEPANU: Ärge kasutage elektritööriistu kokkupanekuks.

TÄHELEPANU: Hoidke grilli kaas kokkupaneku või liigutamise ajal suletuna.



Ostetud mudel võib natuke erineda illustatsioonist. Kokkupanek peab toimuma kahe inimese poolt. Veenduge, et kõik kruvid on kindlalt kinni keeratud. Kontrollige regulaarselt, et kruvid püsivad kindlalt.

TURVALLISUUSOHJEET



VAARA: Tukehtumis/nielaisemisvaara – voi johtaa hengenvaaraan. Pidä pakkausmateriaalit poissa lasten ulottuvilta ja hävitä ne välittömästi. Säilytä pienet osat lasten ulottumattomissa.

VAROITUS: Vaikka kaikki osat on valmistettu huolellisesti, jotkut niistä voivat olla teräväreunaisia. Käytä suojakäsineitä leikkausvammojen välttämiseksi.

HUOMIO: Poista kaikki pakkausmateriaalit ja suojakalvot osista ennen kokoamista.

HUOMIO: Kokoa grilli tasaiselle, pehmeälle ja vakaalle alustalle vaurioiden välttämiseksi.

HUOMIO: Älä käytä sähkötyökaluja kokoamiseen.

HUOMIO: Pidä kannellinen grilli suljettuna kokoamisen tai siirtämisen aikana.



Ostettu malli saattaa poiketa hieman kuvasta. Kokoaminen on tehtävä kahden henkilön voimin. Varmista, että kaikki ruuvit on kiristetty kunnolla. Tarkista säännöllisesti, että ruuvit pysyvät tiukalla.

CONSIGNES DE SÉCURITÉ



DANGER : Risque de mort par étouffement/ingestion. Tenir les matériaux d'emballage hors de portée des enfants et les éliminer immédiatement. Conserver les petites pièces hors de leur portée.

AVERTISSEMENT : Malgré le soin apporté à la fabrication de toutes les pièces, certains éléments peuvent présenter des arêtes vives. Porter des gants de protection pour éviter les coupures.

ATTENTION : Avant de commencer le montage, retirer tous les matériaux d'emballage et les films de protection des différentes pièces.

ATTENTION : Monter le barbecue sur une surface plane, stable et souple afin d'éviter tout dommage.

ATTENTION : Ne pas utiliser d'outils électriques pour le montage.

ATTENTION : Garder le couvercle de cuisson fermé lors de l'assemblage ou du déplacement du barbecue.



Le modèle acheté peut différer légèrement de l'illustration. Le montage doit être effectué par deux personnes. Veillez à ce que toutes les vis soient bien serrées. Vérifiez régulièrement que toutes les vis sont toujours bien fixées.

fi

es

fr

et

SIGURNOSNE UPUTE

hr



OPASNOST: Opasnost od gušenja ili gutanja koja može dovesti do smrti. Držite materijal za pakiranje izvan dohvata djece i odmah ga odbacite. Male dijelove držite izvan dohvata djece.

UPOZORENJE: Unatoč pažljivoj izradi, neki dijelovi mogu imati oštre rubove. Nosite zaštitne rukavice kako biste izbjegli posjekotine.

PAŽNJA: Prije početka montaže uklonite sve materijale za pakiranje i zaštitne folije s dijelova.

PAŽNJA: Montirajte roštilj na ravnoj, glatkoj i mekoj podlozi kako biste izbjegli oštećenja.

PAŽNJA: Ne koristite električne alate za montažu.

PAŽNJA: Tijekom montaže ili pomicanja roštilja držite poklopac zatvorenim.



Kupljeni model može se neznatno razlikovati od prikaza. Montažu moraju izvesti dvije osobe. Pazite da su svi vijci čvrsto stegnuti. Redovito provjeravajte da li su svi vijci čvrsto pričvršćeni.

BIZTONSÁGI UTASÍTÁSOK

hu



VESZÉLY: Fulladás- vagy lenyelésveszély, amely halálos lehet. Tartsa a csomagolóanyagokat távol a gyermekektől, és azonnal dobja ki. Kis alkatrészeket tartsa gyermekektől távol.

FIGYELMEZTETÉS: Minden alkatrészt gondosan gyártottak, de egyes részek éles élűek lehetnek. Viseljen védőkesztyűt a vágások elkerülése érdekében.

FIGYELEM: A szerelés megkezdése előtt távolítsa el az összes csomagolóanyagot és védőfóliát az alkatrészekről.

FIGYELEM: A grillsütőt sík, egyenes és puha felületen szerelje össze, hogy elkerülje a sérüléseket.

FIGYELEM: Ne használjon elektromos szerszámokat a szereléshez.

FIGYELEM: A grill összeszerelése vagy mozgatása során tartsa a sütőtetőt zárva.



A megvásárolt modell kissé eltérhet az ábrázolástól. A szerelést két személynek kell elvégeznie. Győződjön meg róla, hogy minden csavar szorosan meg van húzva. Rendszeresen ellenőrizze a csavarok szoros illeszkedését.

ÖRYGGISLEIÐBEININGAR

is



HÆTTA: Hætta á köfnun eða kyngingu sem getur leitt til dauða. Geymið umbúðir fjarri börnum og fargið þeim strax. Geymið smáhluti utan seilingar barna.

AÐVÖRUN: Þrátt fyrir vandaða framleiðslu geta sumir hlutar haft beitta kanta. Notið hlífðarhanska til að forðast skurði.

VARÚÐ: Fjarlægjið allt umbúðarefni og hlífðarfilmur af hlutunum áður en samsetning hefst.

VARÚÐ: Setjið grillið saman á sléttu, jafnu og mjúku undirlagi til að koma í veg fyrir skemmdir.

VARÚÐ: Notið ekki rafmagnsverkfæri við samsetningu.

VARÚÐ: Haltu grilllokinu lokuðu meðan á samsetningu eða flutningi stendur.



Sú vara sem keypt var getur verið örlítið frábrugðin þeirri sem sýnd er á myndinni. Samsetningu verður að framkvæma af tveimur einstaklingum. Gakktu úr skugga um að allar skrúfur séu vel hertar. Athugaðu reglulega hvort skrúfurnar séu ennþá þéttar.

ISTRUZIONI DI SICUREZZA

it



PERICOLO: Pericolo di morte per soffocamento/ingestione. Tenere i materiali di imballaggio lontani dalla portata dei bambini e smaltirli immediatamente. Conservare le piccole parti fuori dalla loro portata.

AVVERTENZA: Nonostante l'accurata lavorazione di tutte le parti, alcuni componenti possono avere bordi taglienti. Indossare guanti di protezione per evitare tagli.

ATTENZIONE: Prima del montaggio, rimuovere tutti i materiali di imballaggio e le pellicole protettive dai singoli componenti.

ATTENZIONE: Montare il barbecue su una superficie piana, livellata e morbida per evitare danni.

ATTENZIONE: Non utilizzare utensili elettrici per il montaggio.

ATTENZIONE: Durante l'assemblaggio o lo spostamento del barbecue, tenere sempre chiuso il coperchio di cottura.



Il modello acquistato può differire leggermente da quello illustrato. Il montaggio deve essere eseguito da due persone. Assicurarsi che tutte le viti siano ben serrate. Controllare regolarmente che tutte le viti siano ancora ben fissate.

SAUGOS INSTRUKCIJOS

lt



PAVOJUS: Gyvybei pavojus dėl užduso arba praryjimo. Laikykite pakuotės medžiagas vaikams nepasiekiamoje vietoje ir išmeskite iš karto. Smulkias dalis laikykite vaikams nepasiekiamoje vietoje.

ĮSPĖJIMAS: Nors visos dalys pagamintos kruopščiai, kai kurios gali turėti aštrius kraštus. Dėvėkite apsaugines pirštines, kad išvengtumėte pjūvių.

ATSARGIAI: Prieš pradėdami montavimą, nuimkite visas pakuotės medžiagas ir apsaugines plėveles nuo dalių.

ATSARGIAI: Sumontuokite kepsninę ant lygios, lygaus ir minkšto pagrindo, kad išvengtumėte pažeidimų.

ATSARGIAI: Montuojant nenaudokite elektrinių įrankių.

ATSARGIAI: Laikykite dangtį uždarytą montavimo ar perkėlimo metu.



Įsigytas modelis gali šiek tiek skirtis nuo iliustracijos. Montavimą turi atlikti du asmenys. Įsitinkite, kad visi varžtai yra gerai priveržti. Reguliariai tikrinkite, ar varžtai tvirtai laikosi.

DROŠĪBAS NORĀDĪJUMI

lv



BRIESMAS: Dzīvībai bīstams nosmakšanas vai norīšanas risks. Uzglabājiet iepakojuma materiālus bērniem nepieejamā vietā un nekavējoties izmetiet.

Mazās daļas glabājiet bērniem nepieejamā vietā.

BRĪDINĀJUMS: Neskatoties uz rūpīgu izgatavošanu, dažām detaļām var būt asas malas. Valkājiet aizsargcimdus, lai izvairītos no griezumiem.

UZMANĪBU: Pirms montāžas noņemiet visu iepakojuma materiālu un aizsargplēves no detaļām.

UZMANĪBU: Montējiet grilu uz līdzenas, vienmērīgas un mīkstas virsmas, lai izvairītos no bojājumiem.

UZMANĪBU: Neizmantojiet elektriskos instrumentus montāžai.

UZMANĪBU: Turiet vāku aizvērtu montāžas vai pārvietošanas laikā.



legādātais modelis var nedaudz atšķirties no attēla. Montāžu jāveic divām personām. Pārliecinieties, ka visi skrūves ir stingri pievilktas. Regulāri pārbaudiet, vai skrūves ir cieši nostiprinātas.

SIKKERHETSINSTRUKSJONER

nb



FARE: Livsfare på grunn av kvelning eller svelging. Hold emballasjemateriale unna barn og kast det umiddelbart. Oppbevar små deler utenfor barns rekkevidde.

ADVARSEL: Til tross for nøye produksjon kan enkelte deler ha skarpe kanter. Bruk vernehansker for å unngå kutt.

OBS: Fjern alt emballasjemateriale og beskyttelsesfilm fra delene før montering.

OBS: Monter grillen på et flatt, jevnt og mykt underlag for å unngå skader.

OBS: Ikke bruk elektroverktøy til monteringen.

OBS: Hold lokket lukket under montering og når grillen flyttes.



Den kjøpte modellen kan avvike noe fra illustrasjonen. Montering må utføres av to personer. Sørg for at alle skruer er godt strammet. Kontroller regelmessig at alle skruer fortsatt sitter godt.

VEILIGHEIDSINSTRUCTIES

nl



GEVAAR: Levensgevaar door verstikking/inslikken. Houd verpakkingsmateriaal buiten het bereik van kinderen en gooi het direct weg. Bewaar kleine onderdelen buiten hun bereik.

WAARSCHUWING: Ondanks zorgvuldige verwerking kunnen sommige onderdelen scherpe randen hebben. Draag beschermende handschoenen om snijwonden te voorkomen.

LET OP: Verwijder alle verpakkingsmaterialen en beschermfolie van de onderdelen voordat u begint met monteren.

LET OP: Monteer de barbecue op een vlakke, stevige en zachte ondergrond om beschadigingen te voorkomen.

LET OP: Gebruik geen elektrisch gereedschap voor de montage.

LET OP: Houd het deksel gesloten tijdens het monteren of verplaatsen van de barbecue.



Het aangekochte model kan enigszins afwijken van de afbeelding. De montage moet door twee personen worden uitgevoerd. Zorg ervoor dat alle schroeven goed zijn aangedraaid. Controleer regelmatig of alle schroeven nog stevig vastzitten.

INSTRUKCJE BEZPIECZEŃSTWA

pl



NIEBEZPIECZEŃSTWO: Ryzyko uduszenia/potknięcia grożące śmiercią. Trzymaj materiały opakowaniowe z dala od dzieci i natychmiast je usuń. Przechowuj małe części poza zasięgiem dzieci.

OSTRZEŻENIE: Pomimo starannej obróbki niektóre części mogą mieć ostre krawędzie. Noś rękawice ochronne, aby uniknąć skaleczeń.

UWAGA: Przed rozpoczęciem montażu usuń wszystkie materiały opakowaniowe i folie ochronne z części.

UWAGA: Montuj grill na płaskiej, równej i miękkiej powierzchni, aby uniknąć uszkodzeń.

UWAGA: Nie używaj narzędzi elektrycznych do montażu.

UWAGA: Podczas montażu lub przemieszczania grilla trzymaj pokrywę zamkniętą.



Zakupiony model może się nieznacznie różnić od ilustracji. Montaż musi być wykonany przez dwie osoby. Upewnij się, że wszystkie śruby są dobrze dokręcone. Regularnie sprawdzaj, czy śruby są mocno zamocowane.

INSTRUÇÕES DE SEGURANÇA

pt



PERIGO: Risco de morte por sufocamento/engolir. Mantenha os materiais de embalagem fora do alcance das crianças e descarte-os imediatamente. Guarde as peças pequenas fora do alcance delas.

AVISO: Apesar da cuidadosa fabricação de todas as peças, algumas podem ter bordas afiadas. Use luvas de proteção para evitar cortes.

ATENÇÃO: Antes de iniciar a montagem, remova todos os materiais de embalagem e as películas protetoras das peças.

ATENÇÃO: Monte a churrasqueira numa superfície plana, nivelada e macia para evitar danos.

ATENÇÃO: Não utilize ferramentas elétricas para a montagem.

ATENÇÃO: Mantenha a tampa fechada durante a montagem ou quando mover a churrasqueira.



O modelo adquirido pode diferir ligeiramente da ilustração. A montagem deve ser realizada por duas pessoas. Certifique-se de que todos os parafusos estão bem apertados. Verifique regularmente se os parafusos continuam firmes.

INSTRUCȚIUNI DE SIGURANȚĂ

ro



PERICOL: Risc de sufocare/înghițire care poate duce la moarte. Țineți materialele de ambalare departe de copii și eliminați-le imediat. Păstrați piesele mici departe de accesul copiilor.

ATENȚIONARE: Deși toate piesele au fost fabricate cu grijă, unele pot avea margini ascuțite. Purtați mănuși de protecție pentru a evita tăieturile.

ATENȚIONARE: Înainte de asamblare, îndepărtați toate materialele de ambalare și foliile de protecție de pe piese.

ATENȚIONARE: Asamblați grătarul pe o suprafață plană, nivelată și moale pentru a evita deteriorarea.

ATENȚIONARE: Nu folosiți unelte electrice pentru asamblare.

ATENȚIONARE: Țineți capacul închis în timpul asamblării sau mutării grătarului.



Modelul achiziționat poate diferi ușor de ilustrație. Asamblarea trebuie făcută de două persoane. Asigurați-vă că toate șuruburile sunt bine strânse. Verificați periodic dacă șuruburile sunt bine fixate.

BEZPEČNOSTNÉ POKYNY

sk



NEBEZPEČENSTVO: Nebezpečnostv udusenia alebo prehltnutia s rizikom smrti. Uchovávať obalový materiál mimo dosahu detí a ihneď ho zlikvidujte. Malé časti uchovávať mimo dosah detí.

UPOZORNENIE: Napriek starostlivej výrobe môžu mať niektoré časti ostré hrany. Noste ochranné rukavice, aby ste predišli porezaniu.

POZOR: Pred začatím montáže odstráňte všetky obalové materiály a ochranné fólie z jednotlivých častí.

POZOR: Gril montujte na rovný, rovnomerný a mäkký povrch, aby ste predišli poškodeniu.

POZOR: Na montáž nepoužívajte elektrické náradie.

POZOR: Počas montáže alebo presunu grilu majte pokrievku zatvorenú.



Zakúpený model sa môže mierne líšiť od zobrazenia. Montáž musí vykonať dve osoby. Dbajte na to, aby boli všetky skrutky pevne utiahnuté. Pravidelne kontrolujte pevnosť skrutiek.

VARNOSTNA NAVODILA

sl



NEVARNOST: Smrtna nevarnost zaradi zadušitve/požiranja. Embalažni material hranite izven dosega otrok in ga takoj zavržite. Majhne dele hranite izven dosega otrok.

OPOZORILO: Kljub skrbni izdelavi imajo nekateri deli lahko ostre robove. Nosite zaščitne rokavice, da preprečite praskanje.

POZOR: Pred začetkom montáže odstranite vse embalažne materiale in zaščitne folije s posameznih delov.

POZOR: Žar sestavite na ravno, enakomerno in mehko podlago, da preprečite poškodbe.

POZOR: Pri montaži ne uporabljajte električnih orodij.

POZOR: Pokrov med montažo ali premikanjem žara vedno držite zaprt.



Kupljeni model se lahko rahlo razlikuje od prikaza. Montažo morata izvesti dve osebi. Poskrbite, da so vsi vijaki dobro zategnjeni. Redno preverjajte, ali so vijaki trdno pritrjeni.

SÄKERHETSANVISNINGAR

sv



FARA: Livsfara på grund av kvävning eller att smådelar sväljs. Håll förpackningsmaterial borta från barn och kassera det omedelbart. Förvara smådelar utom räckhåll för barn.

WARNING: Trots noggrann tillverkning kan vissa delar ha vassa kanter. Använd skyddshandskar för att undvika skärsår.

OBS: Ta bort allt förpackningsmaterial och skyddsfilm från delarna innan montering.

OBS: Montera grillen på en plan, jämn och mjuk yta för att undvika skador.

OBS: Använd inte elverktyg vid montering.

OBS: Håll locket stängt under montering eller när du flyttar grillen.



Den köpta modellen kan avvika något från bilden. Montering måste utföras av två personer. Kontrollera att alla skruvar är ordentligt åtdragna. Kontrollera regelbundet att skruvarna sitter fast.

GÜVENLİK TALIMATLARI

tr



TEHLİKE: Boğulma/yutma sonucu ölüm riski. Ambalaj malzemelerini çocuklardan uzak tutun ve hemen atın. Küçük parçaları çocukların erişemeyeceği yerde saklayın.

UYARI: Tüm parçalar özenle üretilmiş olsa da bazı parçaların keskin kenarları olabilir. Kesikleri önlemek için koruyucu eldiven kullanın.

DİKKAT: Montaja başlamadan önce tüm ambalaj malzemelerini ve koruyucu filmleri parçaların üzerinden çıkarın.

DİKKAT: Hasarları önlemek için ızgarayı düz, seviyeli ve yumuşak bir zeminde monte edin.

DİKKAT: Montaj için elektrikli aletler kullanmayın.

DİKKAT: Iızgarayı monte ederken veya taşırken kapağı kapalı tutun.



Satın alınan model gösterilen resimden biraz farklı olabilir. Montaj iki kişi tarafından yapılmalıdır. Tüm vidaların sıkıca tutulduğundan emin olun. Vidaların sıkılığını düzenli olarak kontrol edin.

1

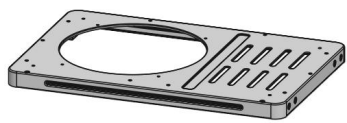

1x

2



4x

3



1x

4

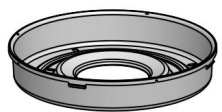

1x

5

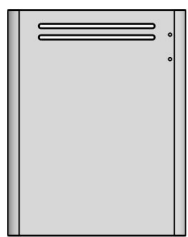

1x

6

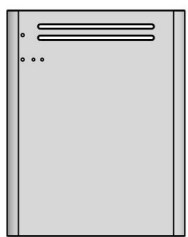

1x

7

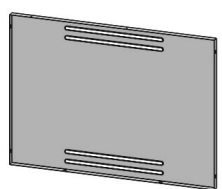

1x

8



2x

9



1x

10

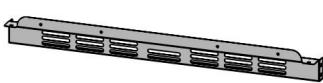

1x

11

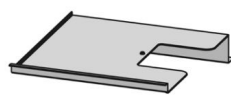

1x

12



4x

13



1x

14



2x

15

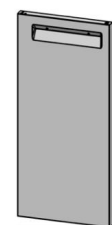

1x

16



1x

17

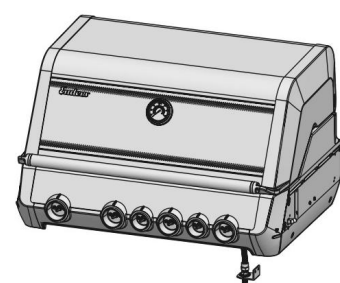

1x

18



3x

19



2x

20



TURBO

1x

21

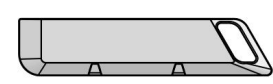

1x

22

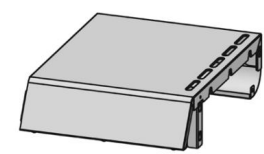

1x

23







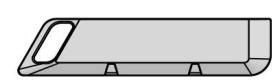

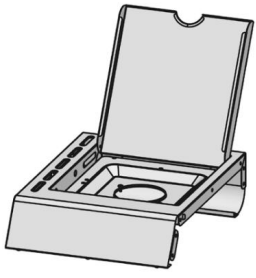

1x

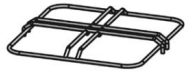

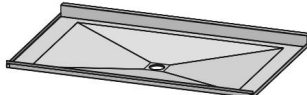
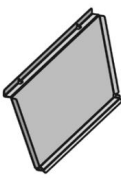
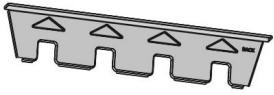
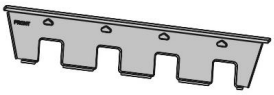
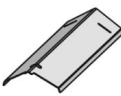
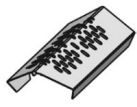
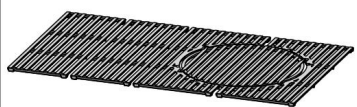
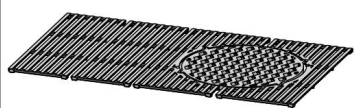







24



1x

25		1x
26		1x
27		1x
28		1x
29		1x
30		1x
31		2x
32		1x
33		1x
34		3x
35		1x
36	 Set of 5	1x
37	 Set of 5	1x

38		1x
39	 Only for item-no. 836233, 836633	1x
40	 Only for item-no. 8362, 8366	1x
41	Incl. weather cover only for item-no. 836221	1x

A	 M6 x 12	32x
B	 M6 x 8	2x
C	 M5 x 10	6x
D	 M4 x 6	4x
E	 M4 x 10	10x
F	 M4 x 15	2x
G	 ST4.2 x 6	4x
H	 ST4.2 x 10	18x
I		1x
J		1x
K	 M6 x 15	4x

01

1	1x
2	4x

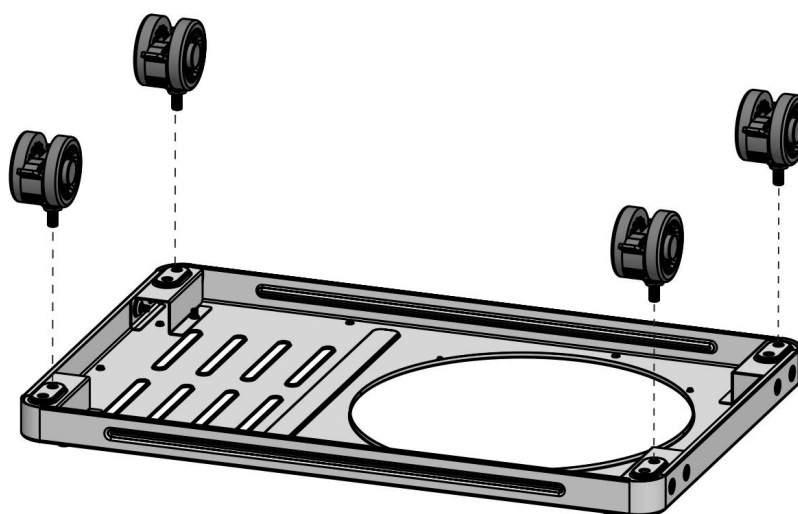

02

3	1x
4	1x

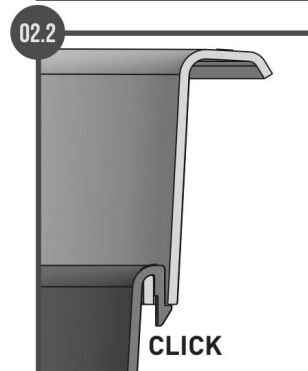
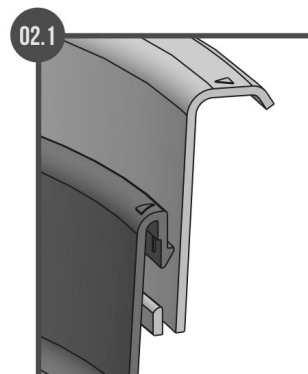
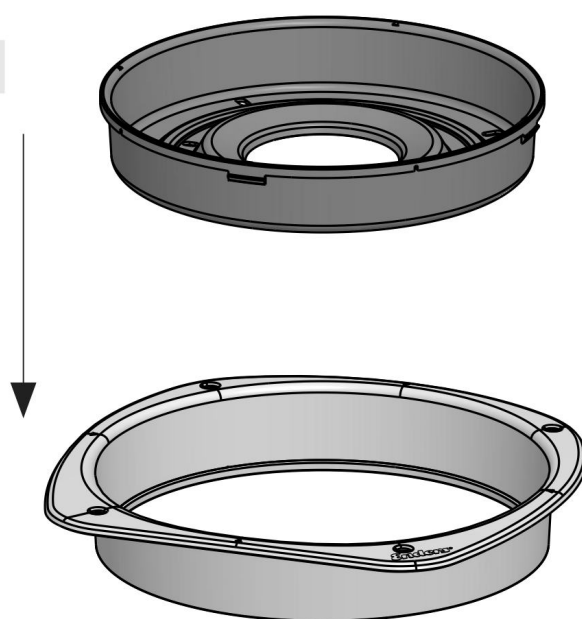

03

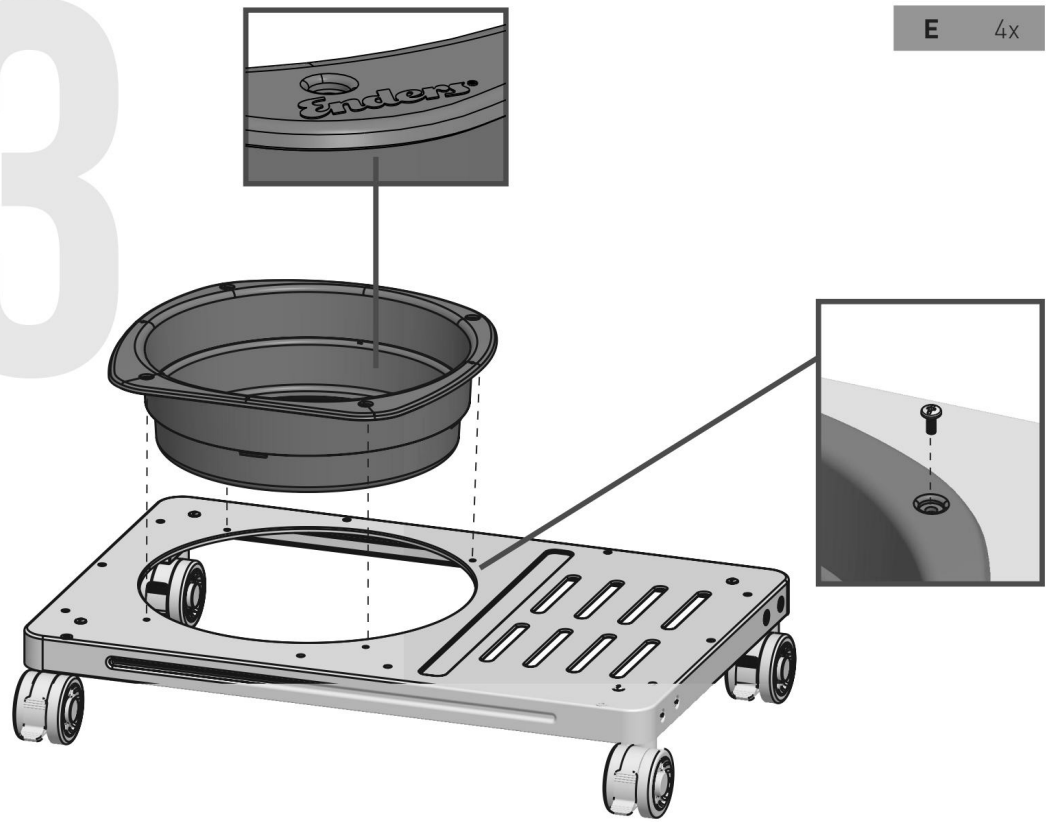

04

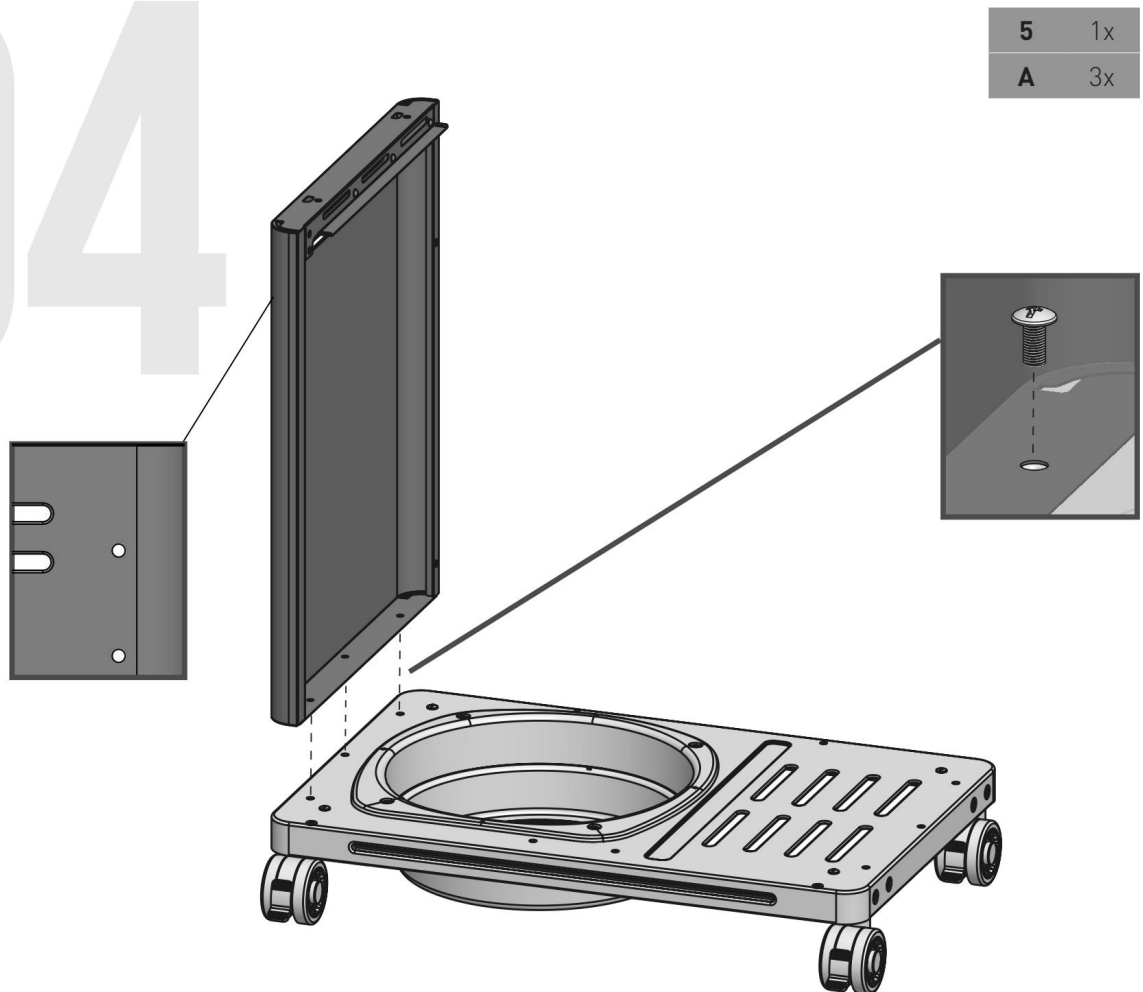

05

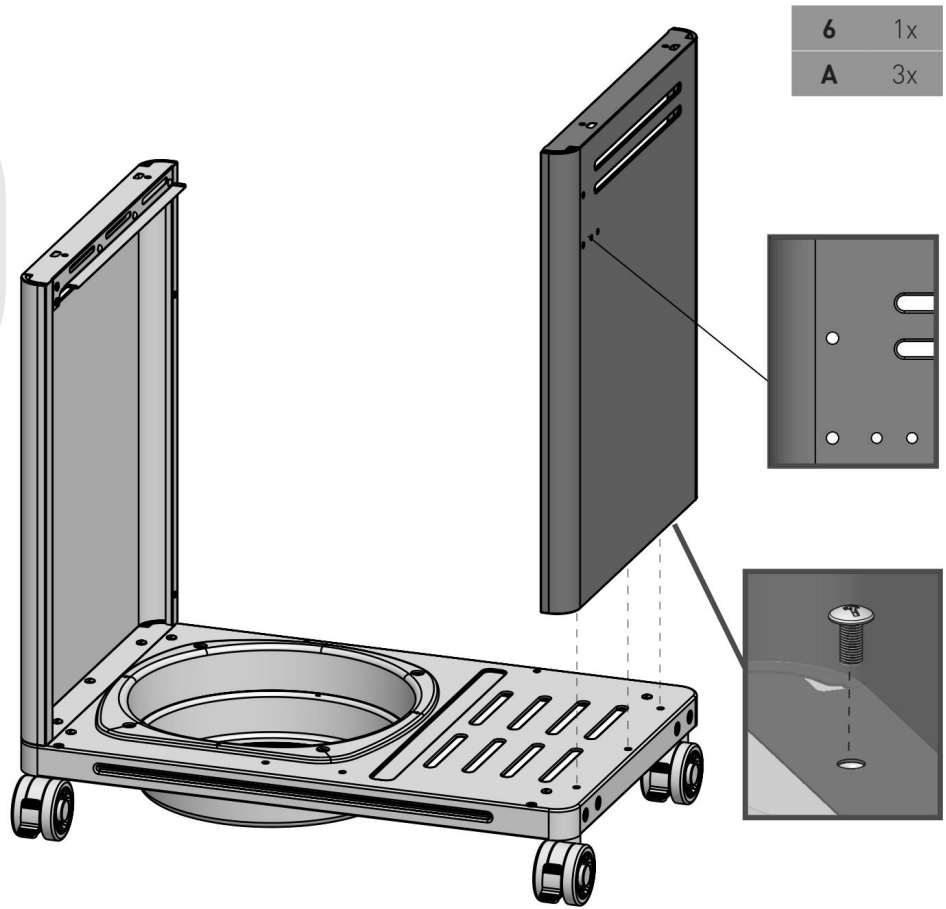

06

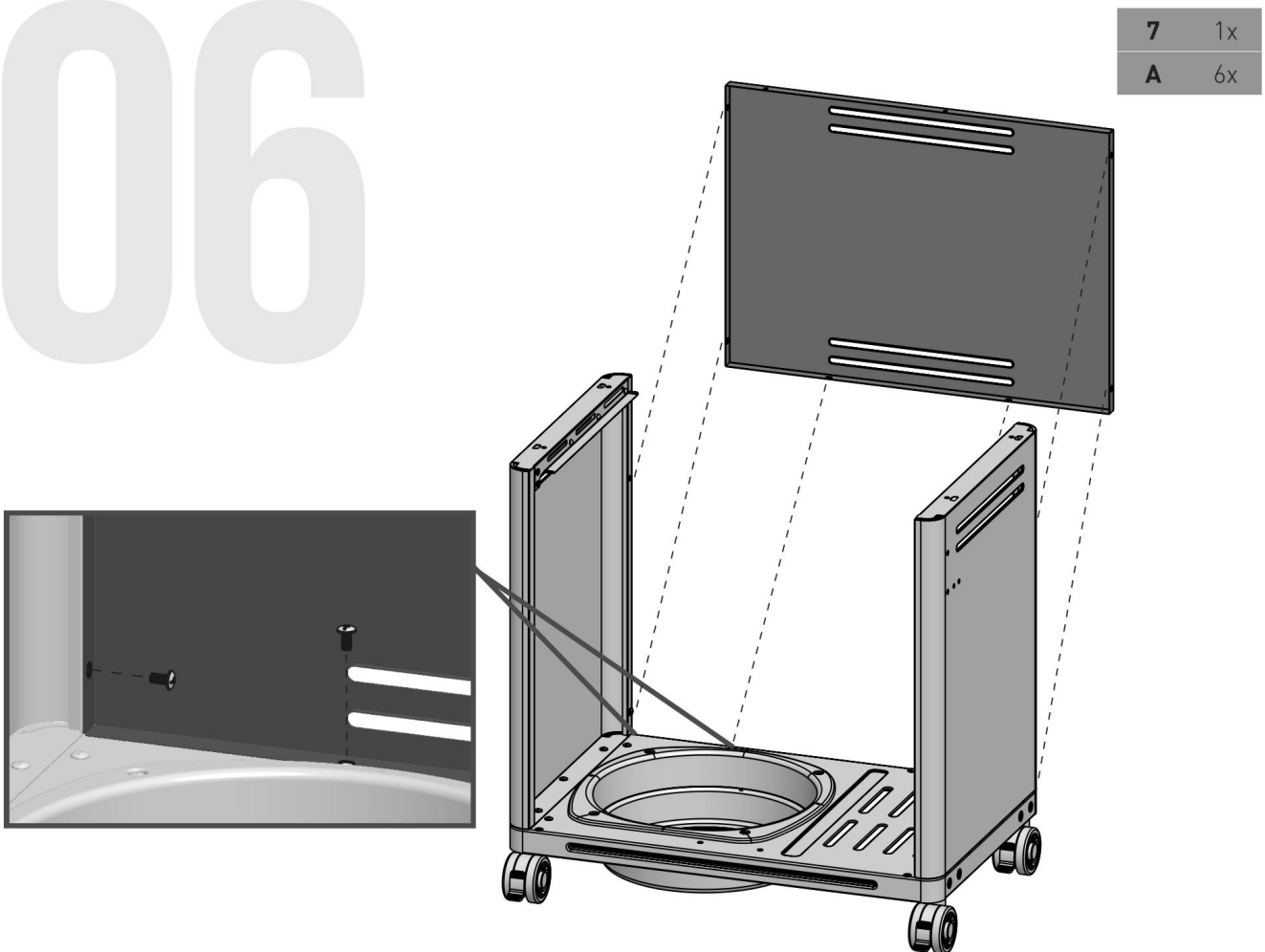

07

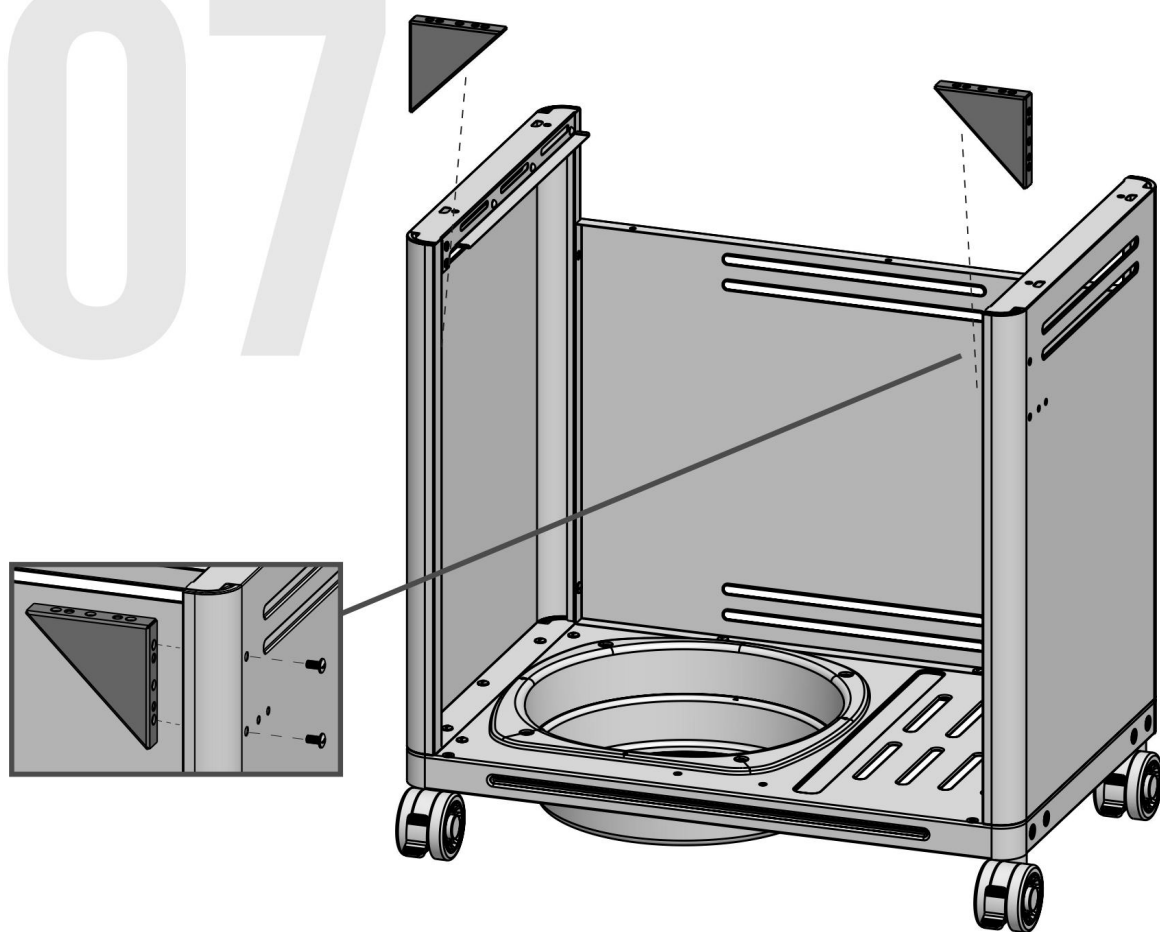

8	2x
A	4x

08

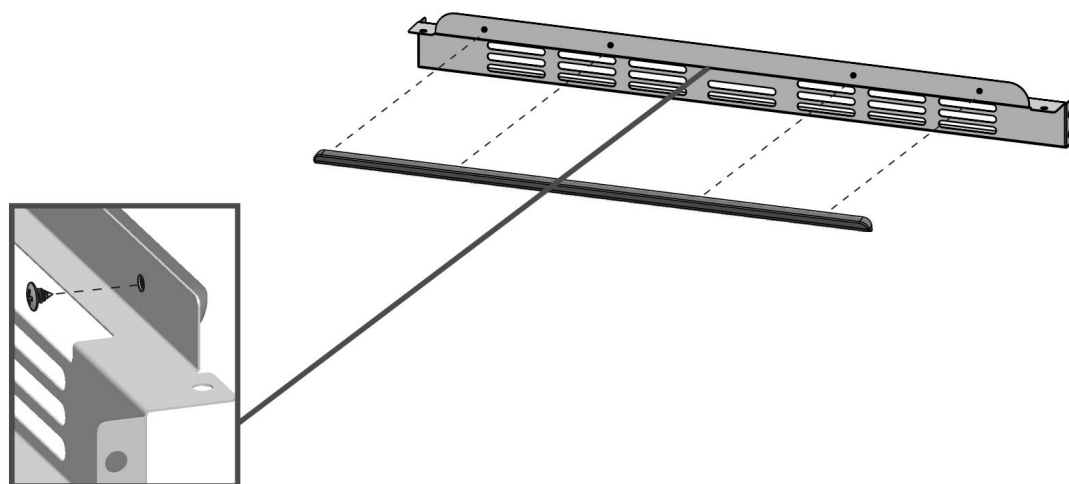

9	1x
10	1x
G	4x

09

A 8x

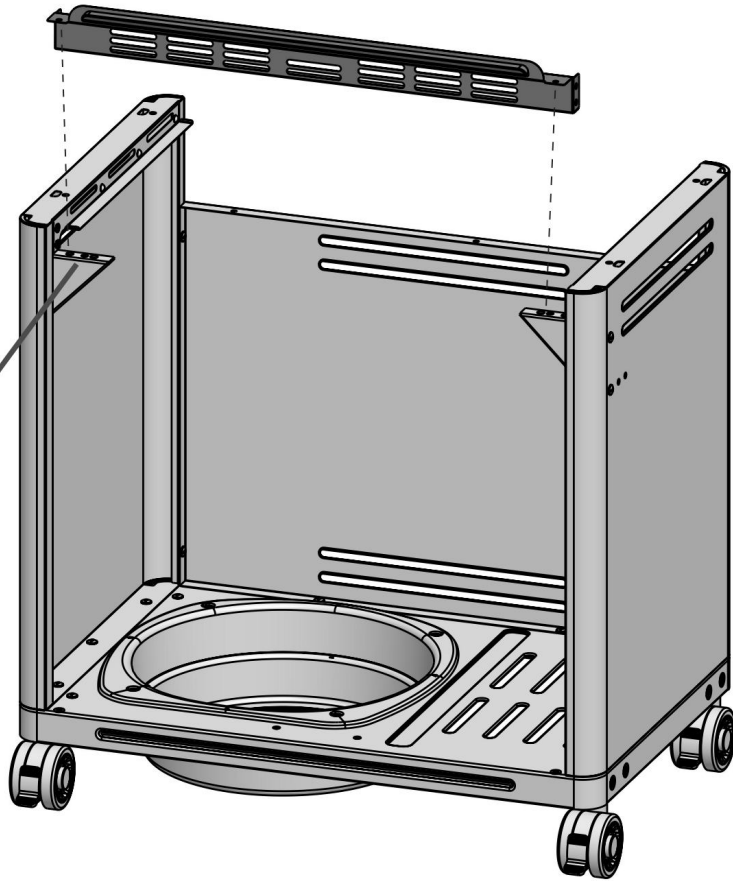
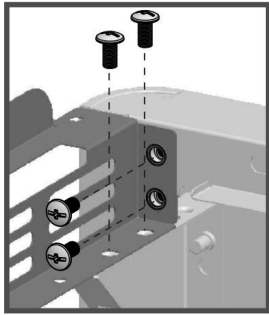

10

12 4x
A 4x

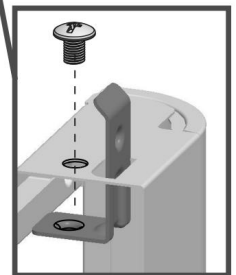
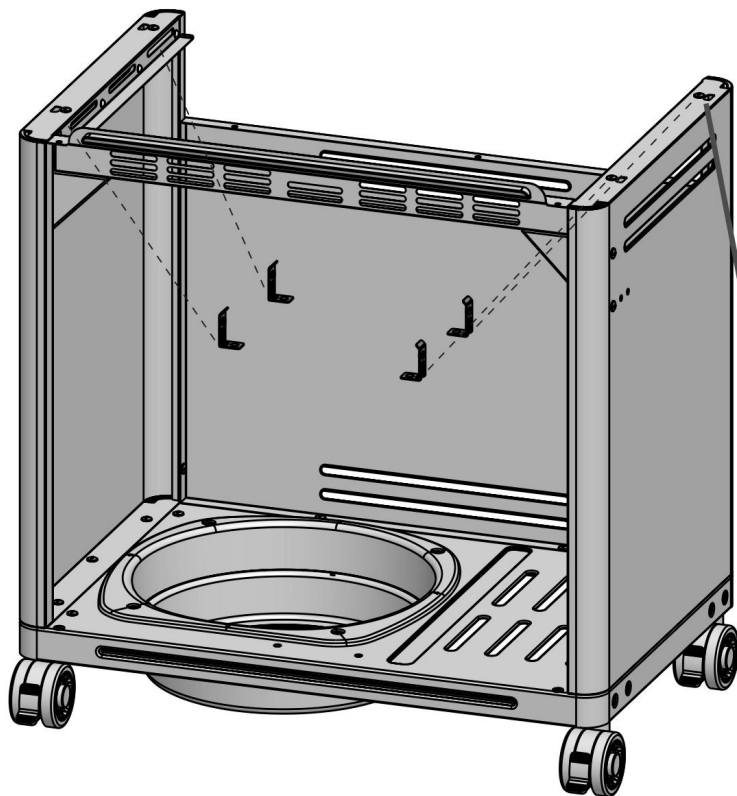

11

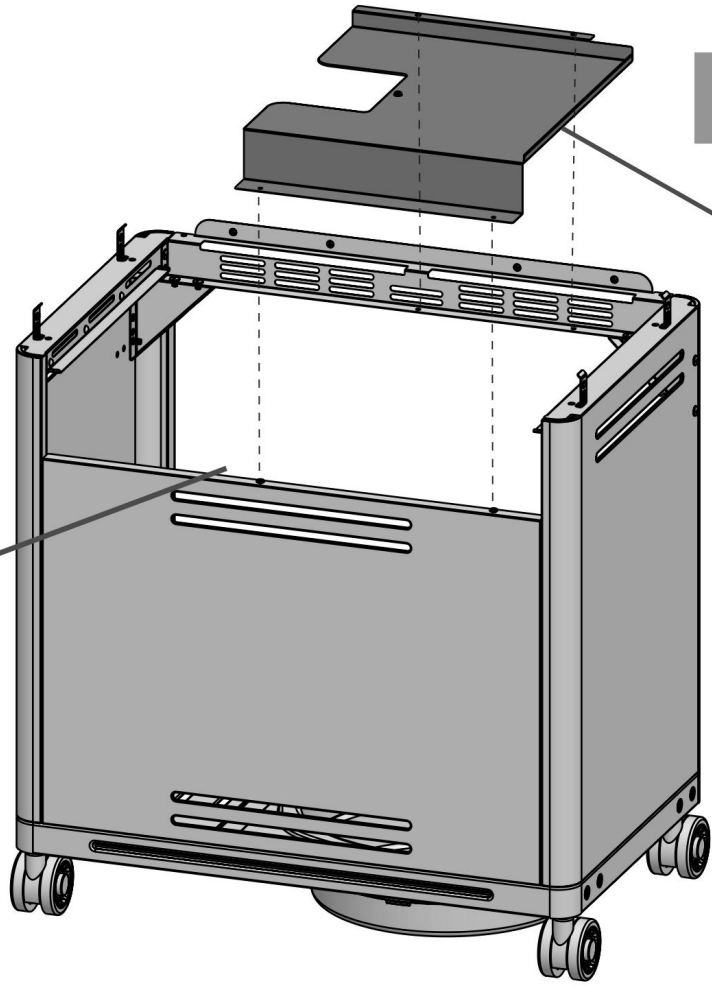
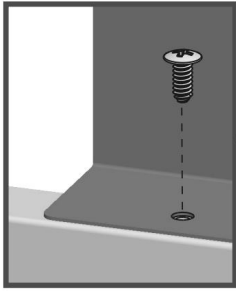

- | | |
|----|----|
| 11 | 1x |
| D | 4x |

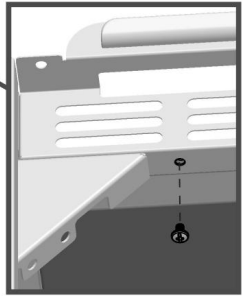

12

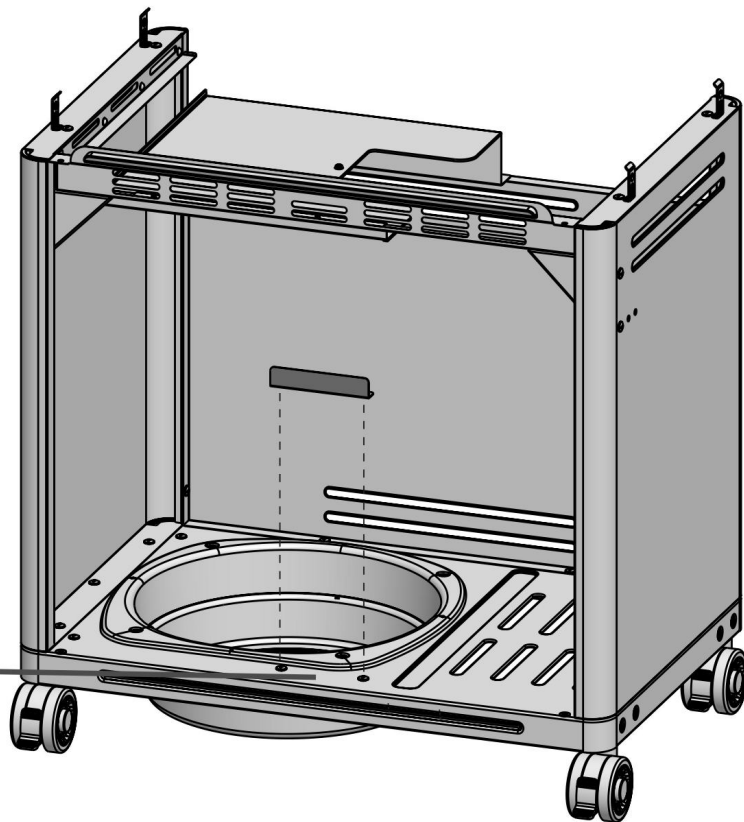
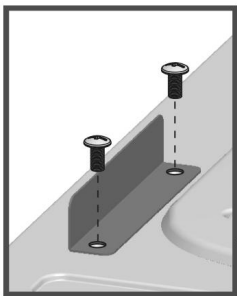

- | | |
|----|----|
| 13 | 1x |
| A | 2x |

13

14	1x
15	1x
D	2x

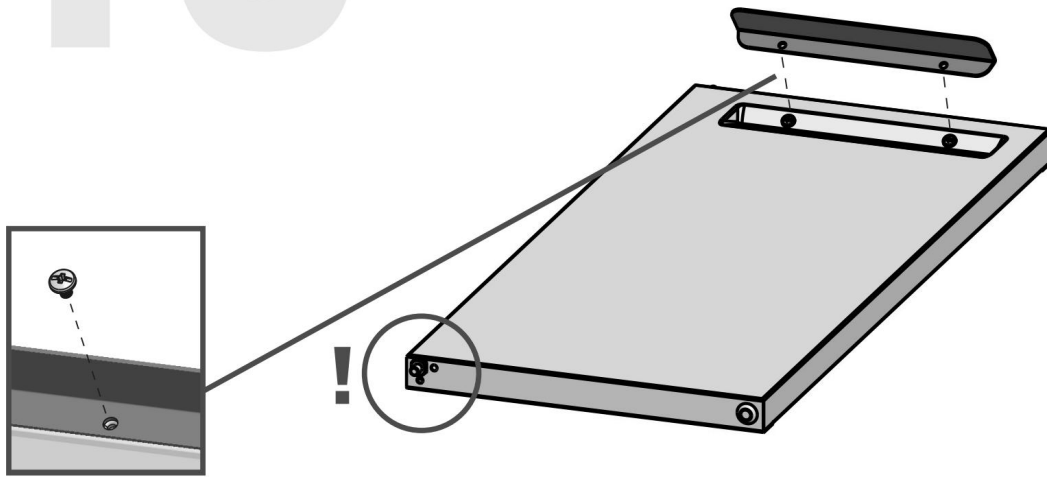

14

14	1x
16	1x
D	2x

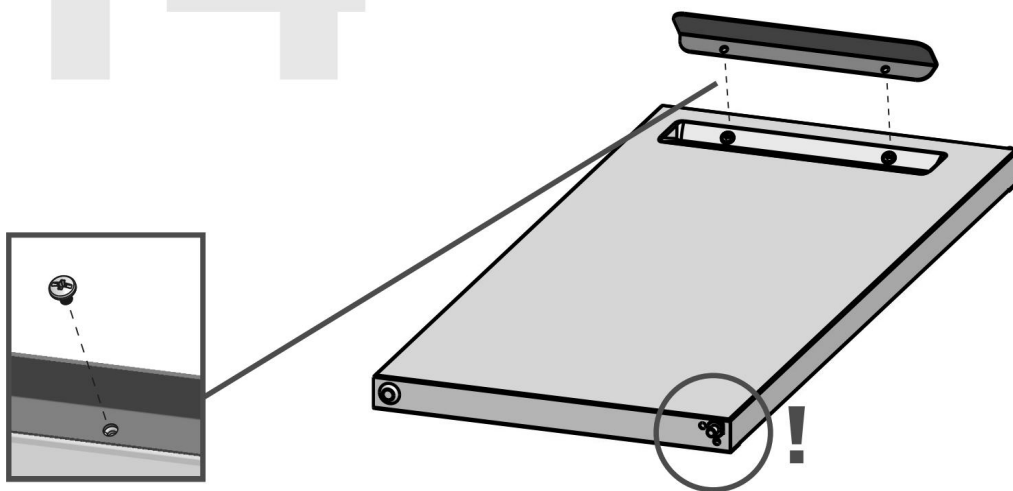

15

15	1x
16	1x
I	1x

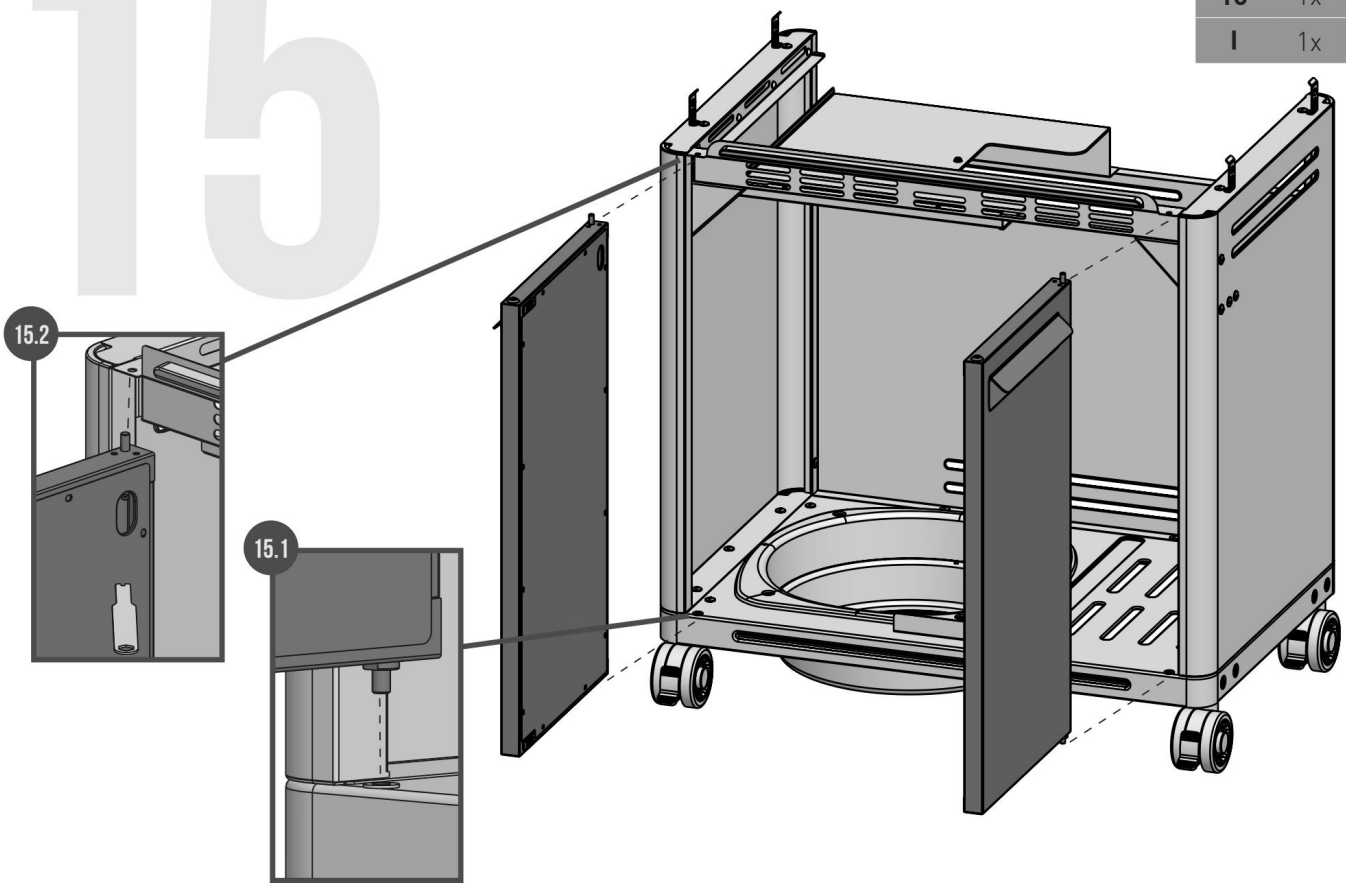

16

17	1x
K	4x

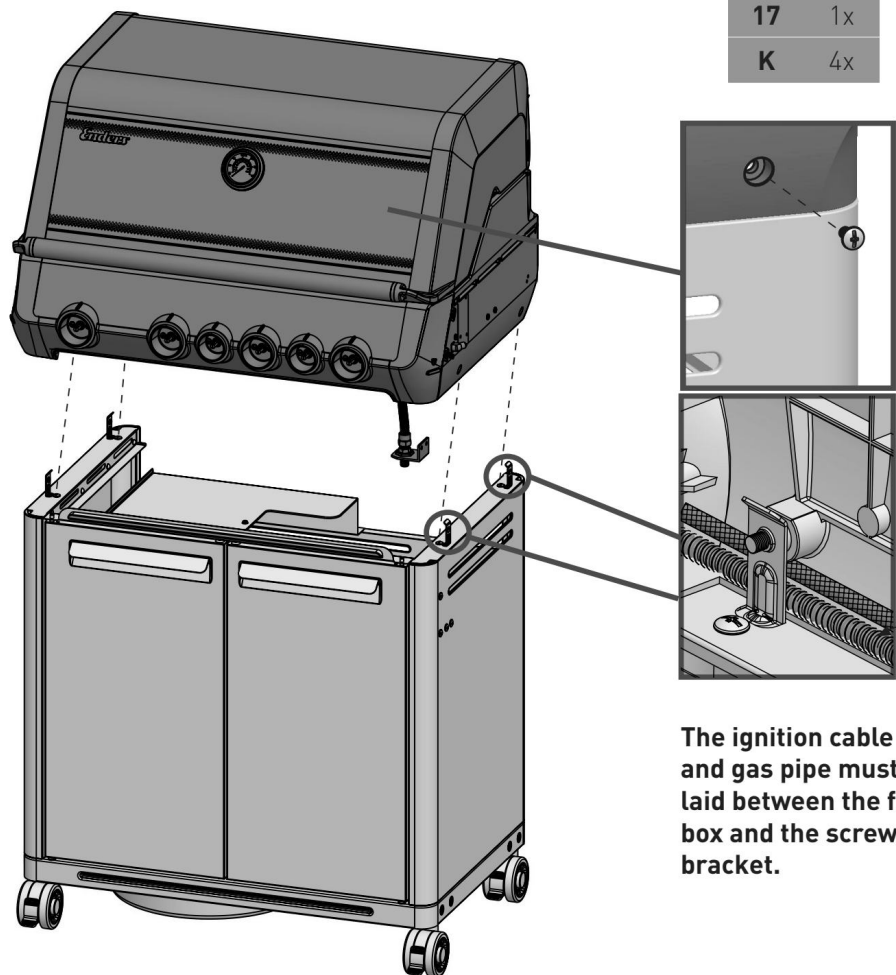

The ignition cable and gas pipe must be laid between the fire-box and the screw-on bracket.

17

18	3x
19	2x
20	1x

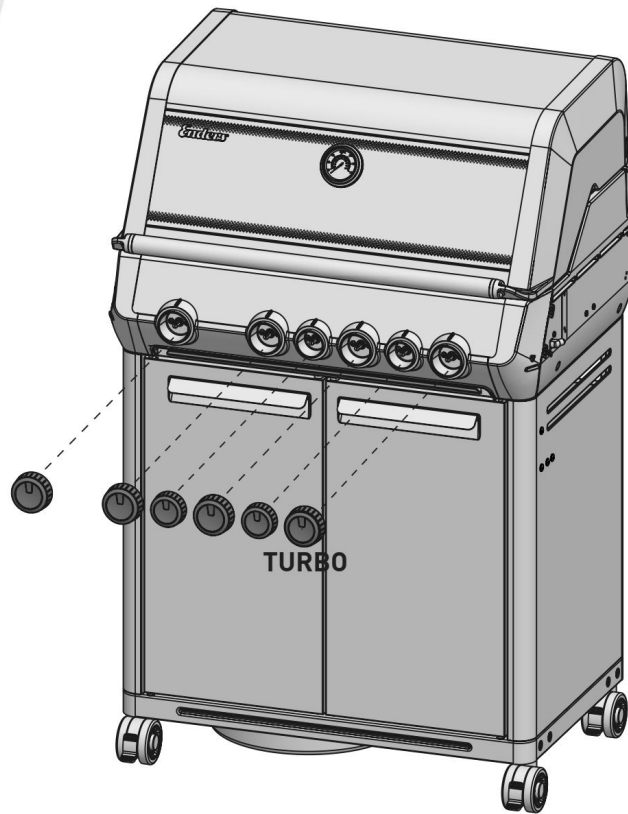

18

21	1x
22	1x
H	7x

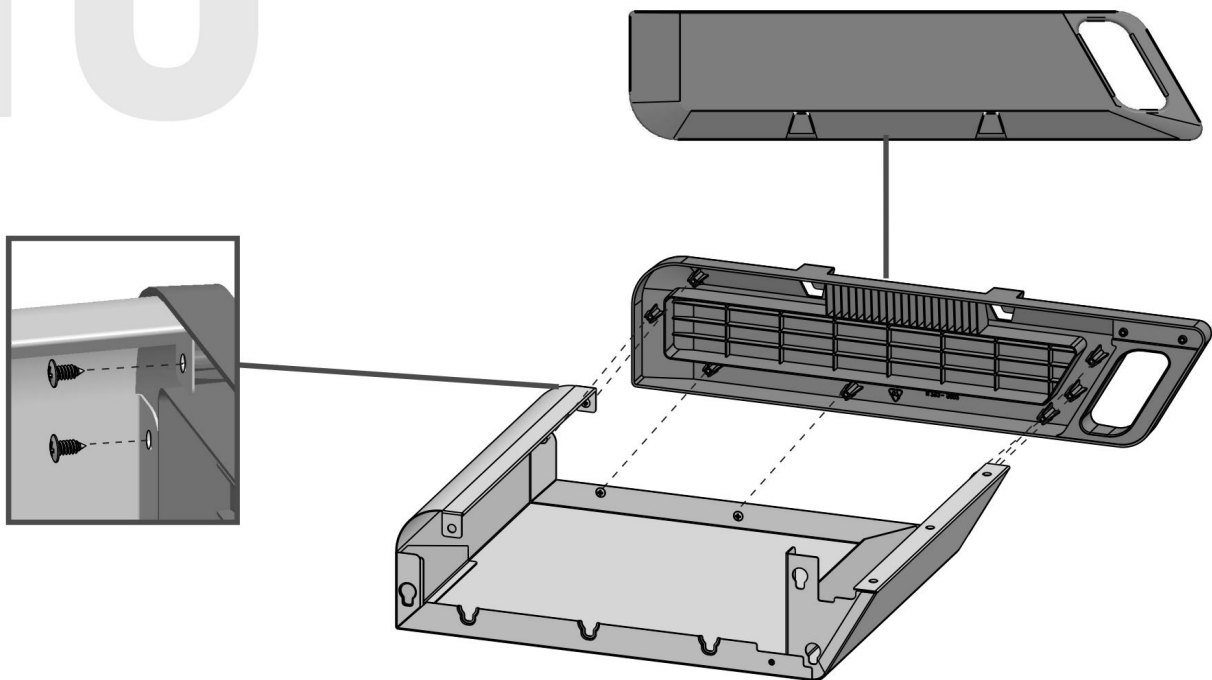

19

23	1x
C	3x
H	2x

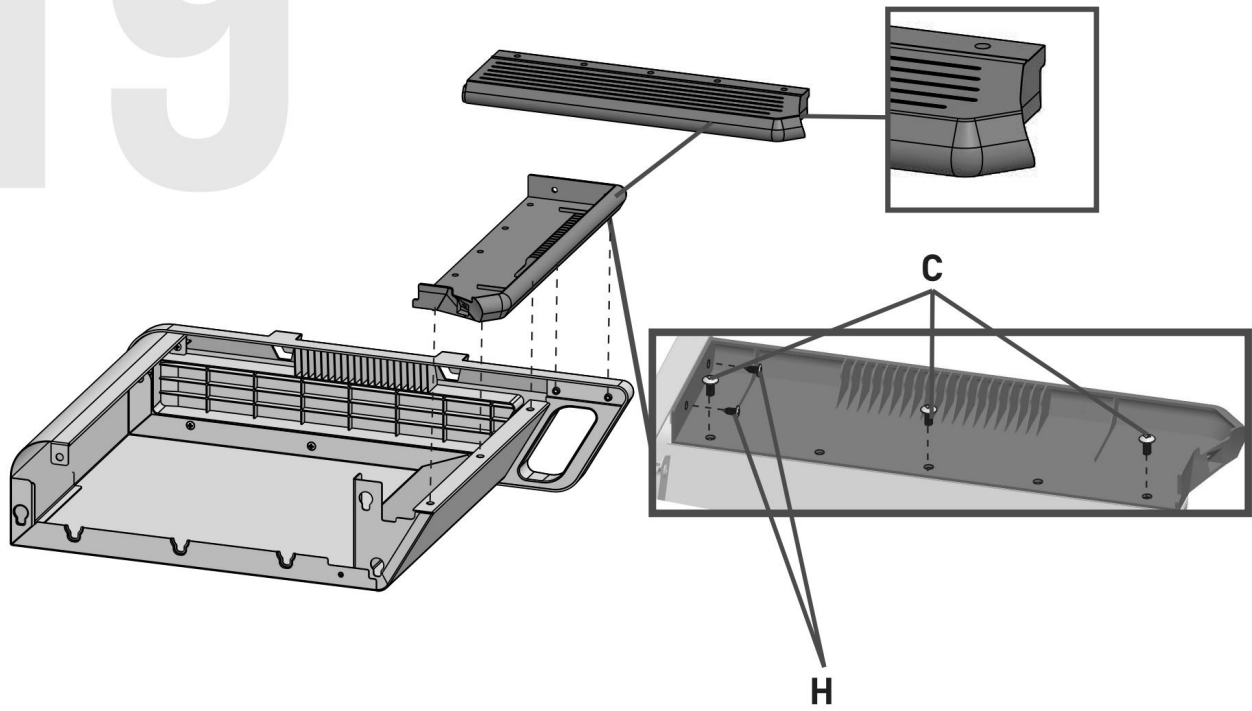

20

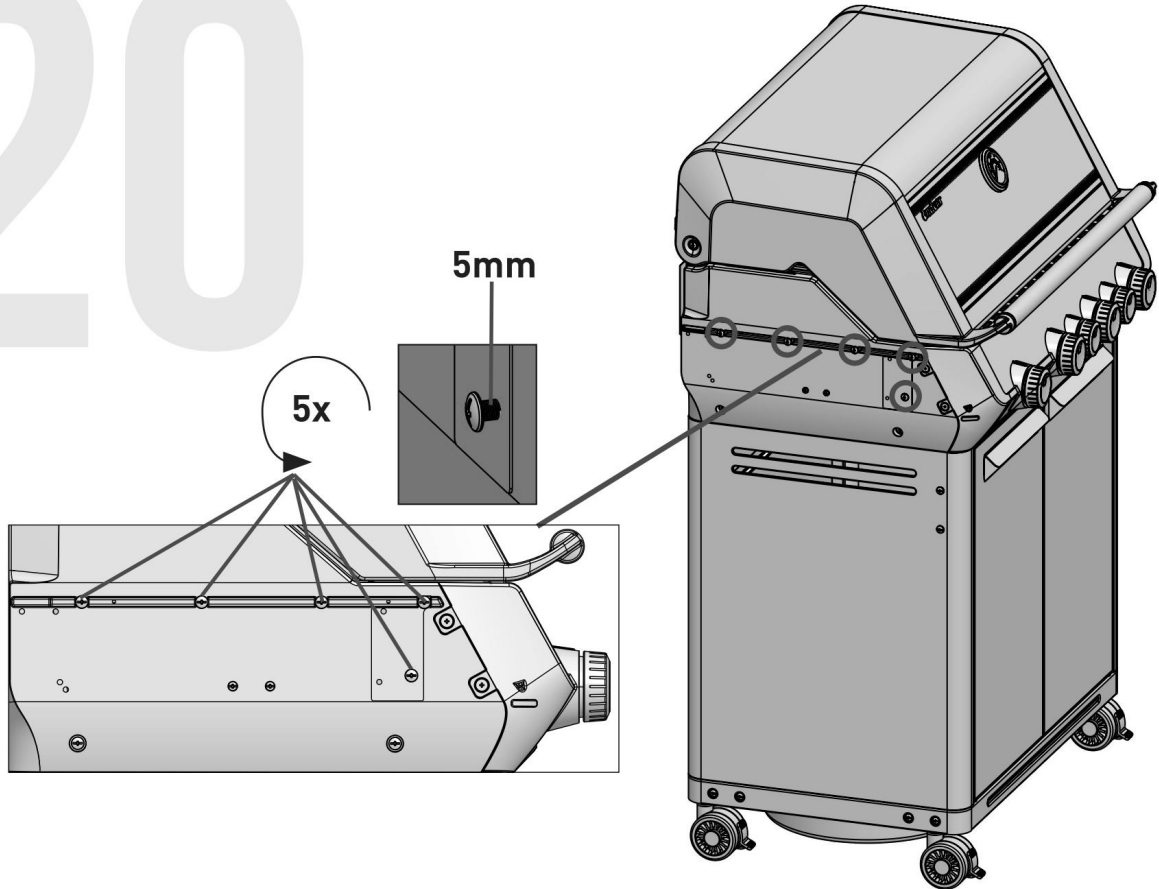

21

B	1x
F	1x

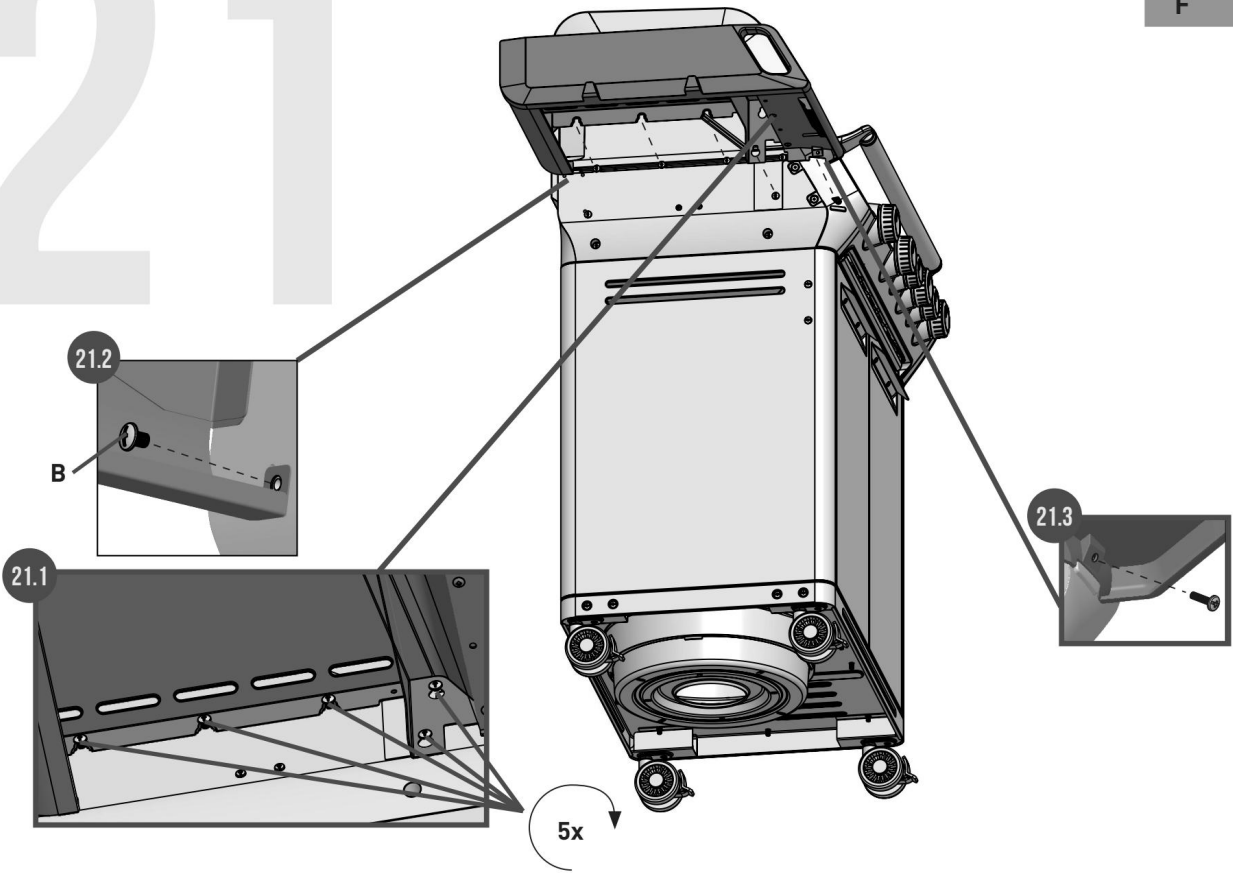

22

24	1x
H	7x

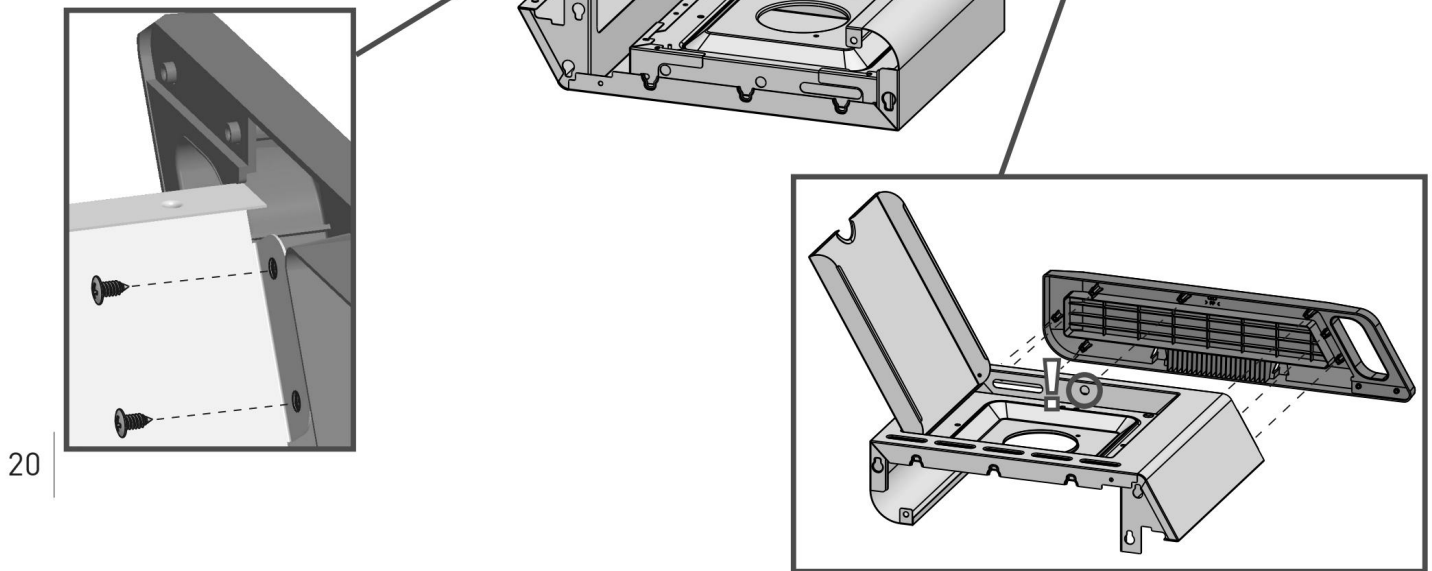

23

26	1x
C	3x
H	2x

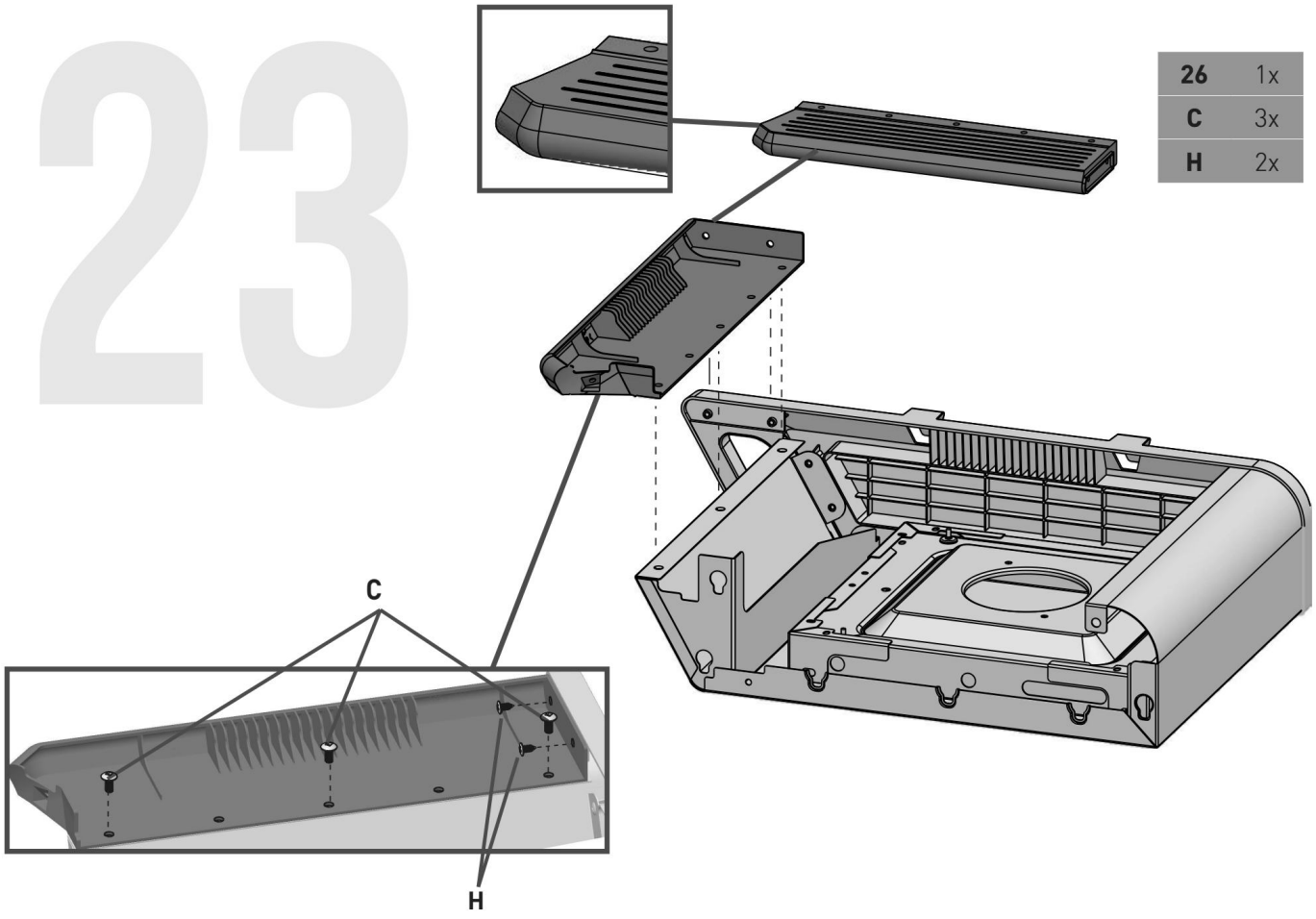

24

5mm

5x

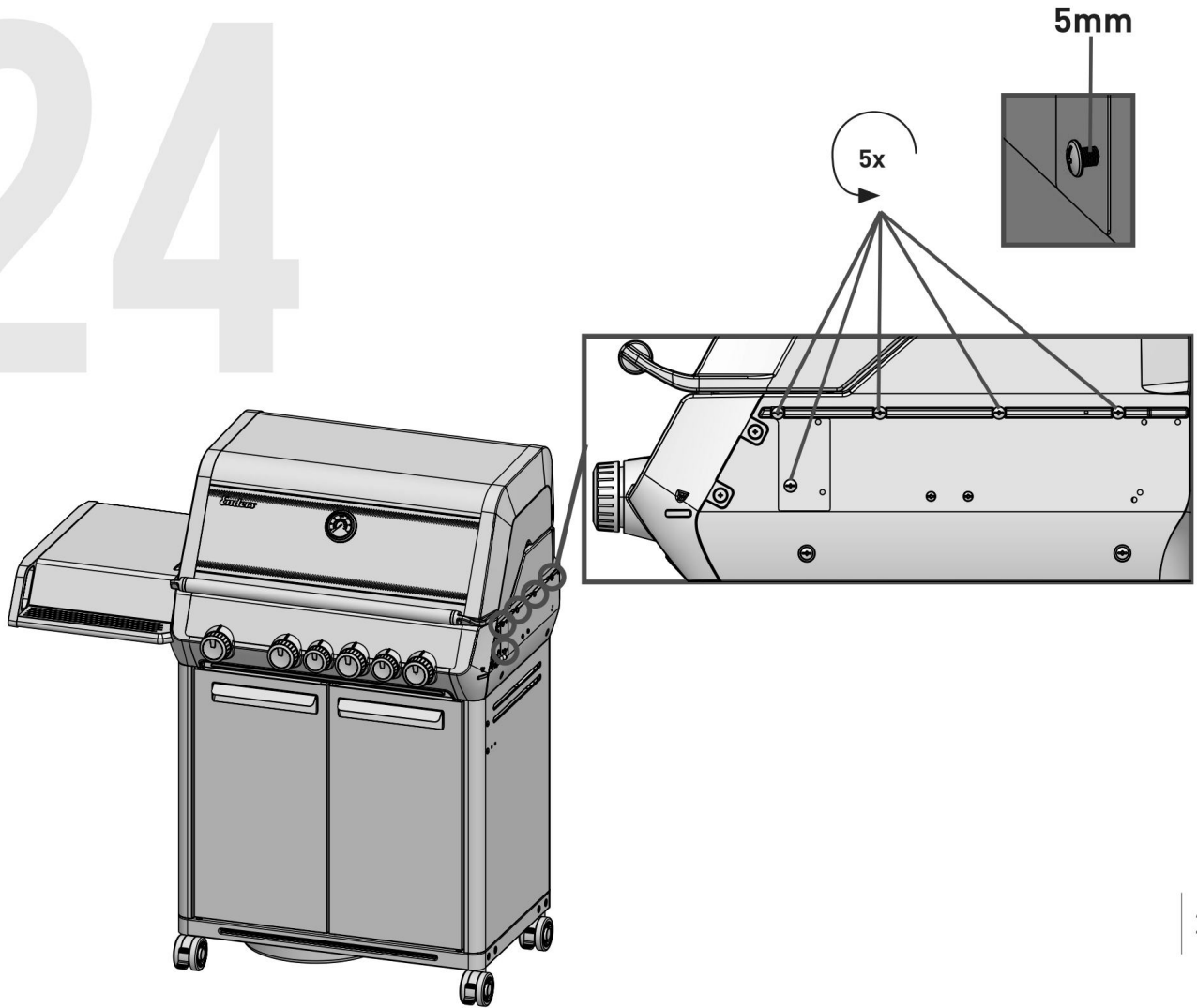

25

B	1x
F	1x

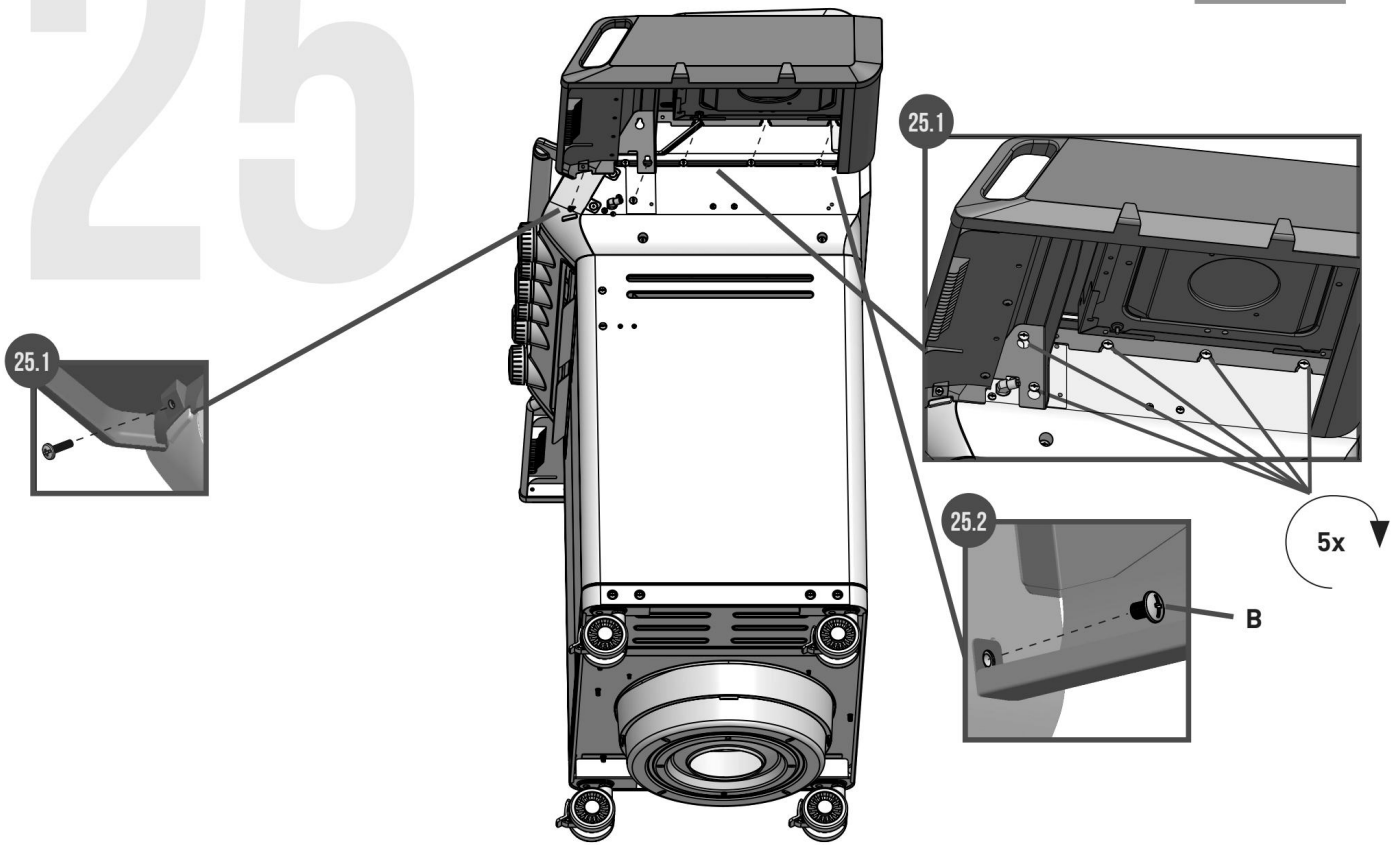

26

27	1x
E	2x

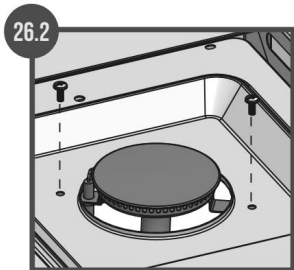
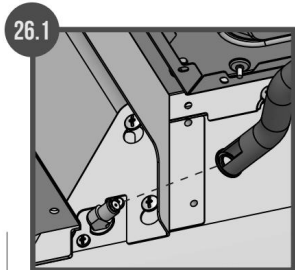
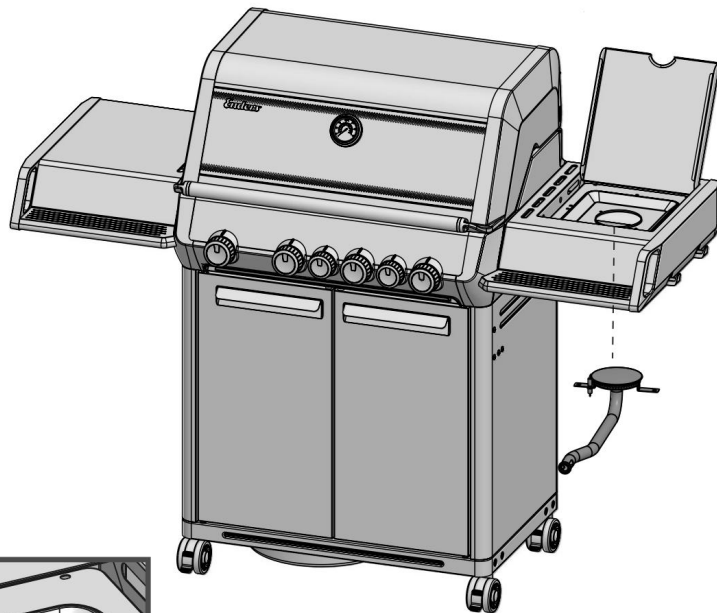

27

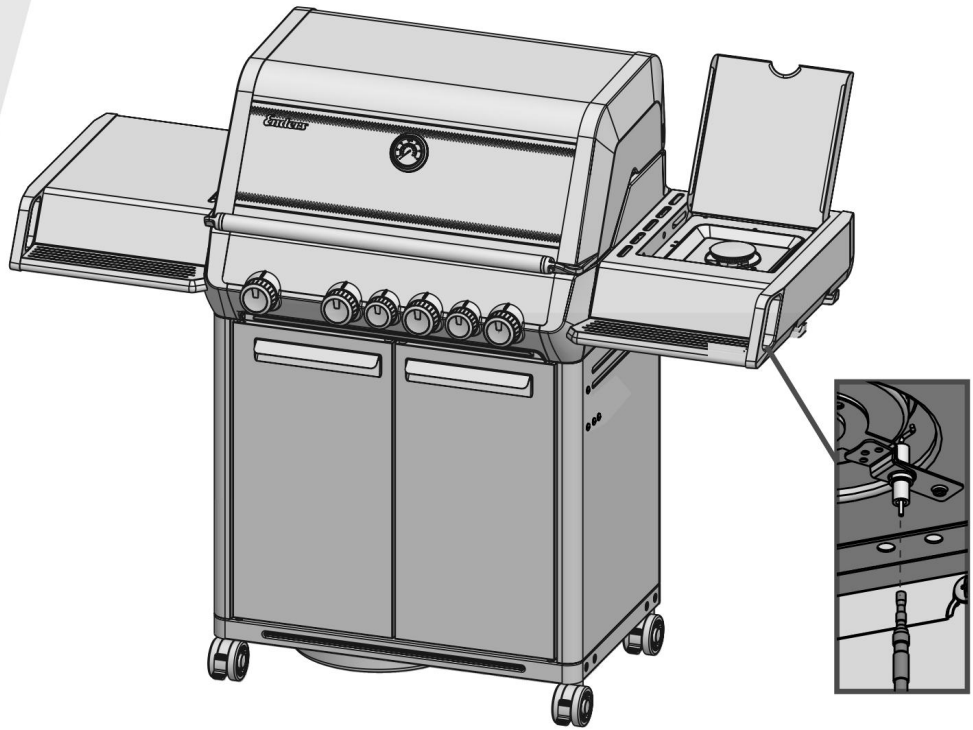

28 1x

28

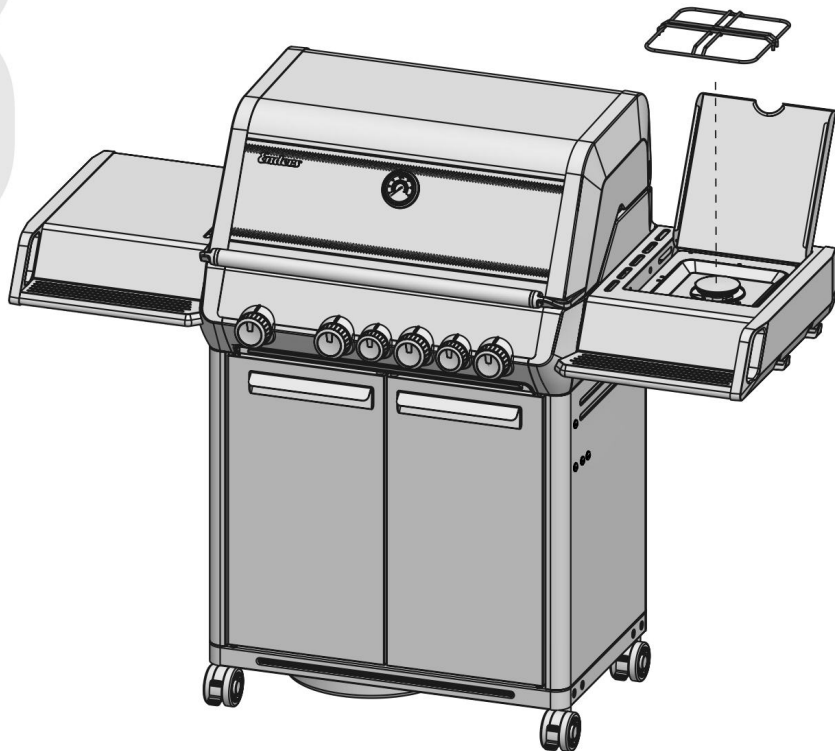

29

29 1x

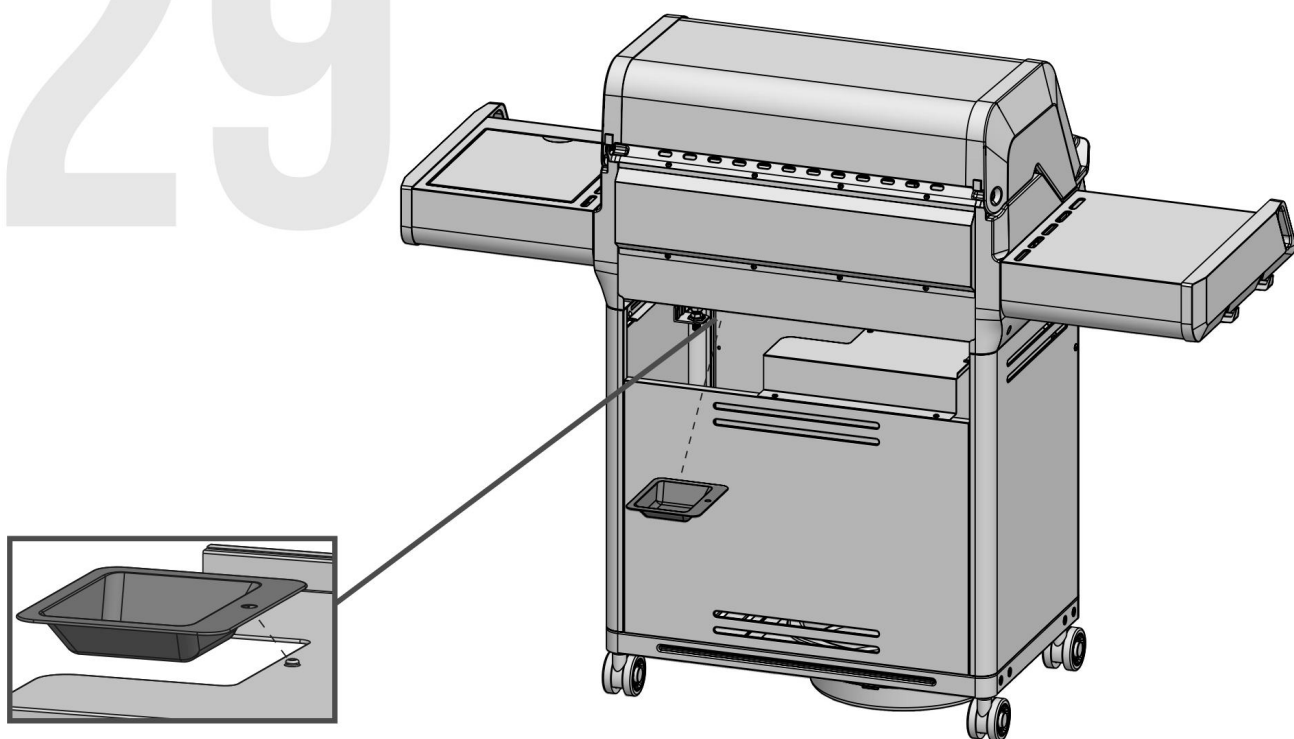

30

30 1x

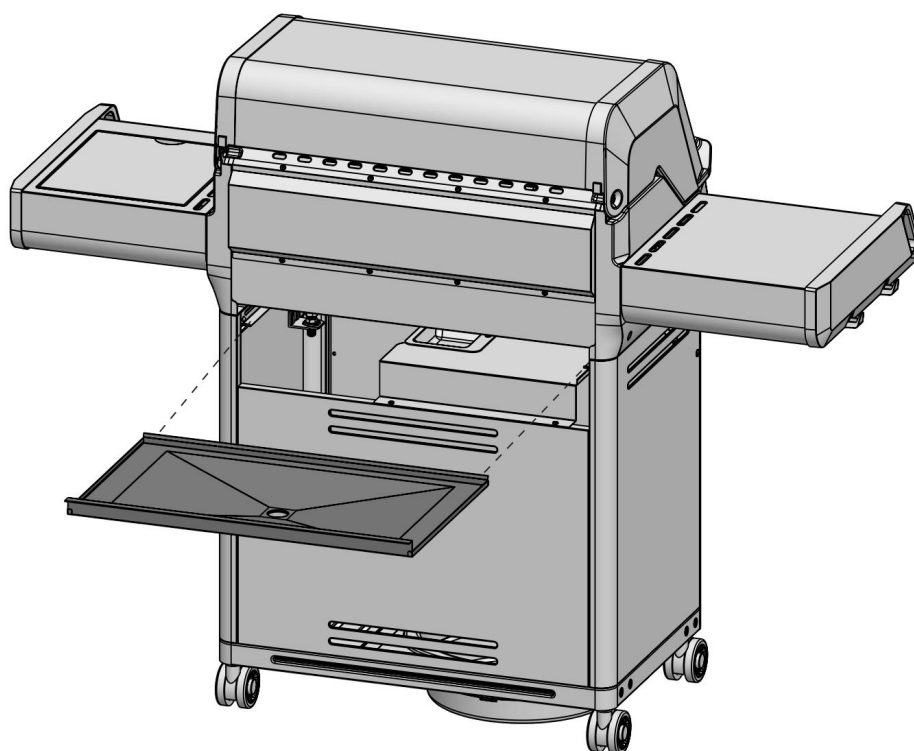

31

A 2x

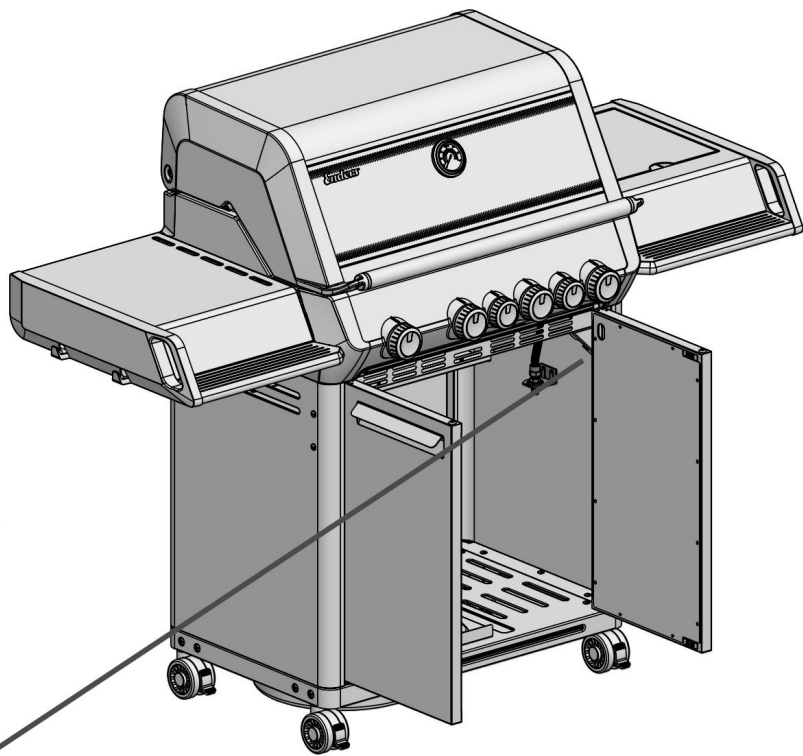
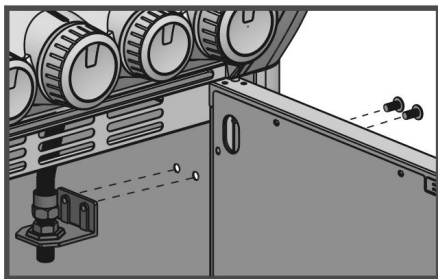

32

31 2x

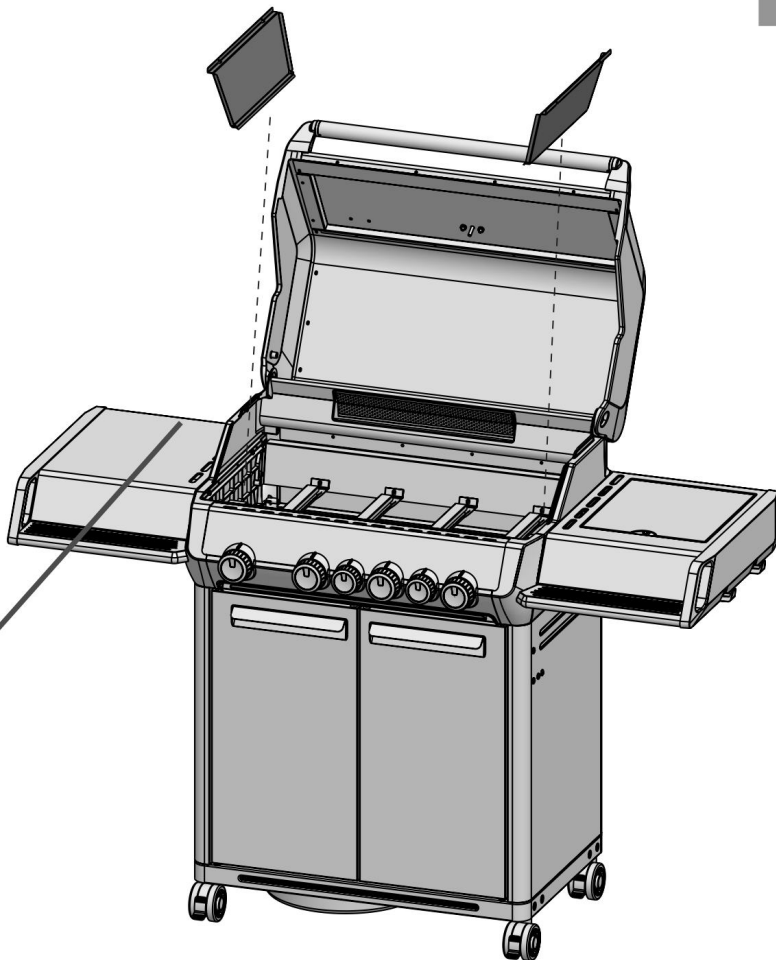
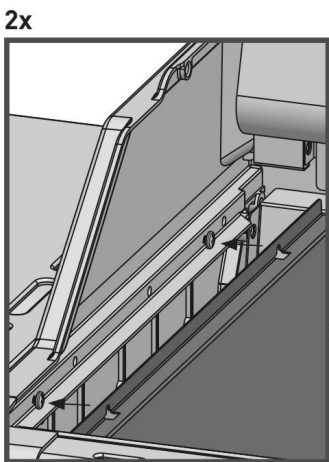

33

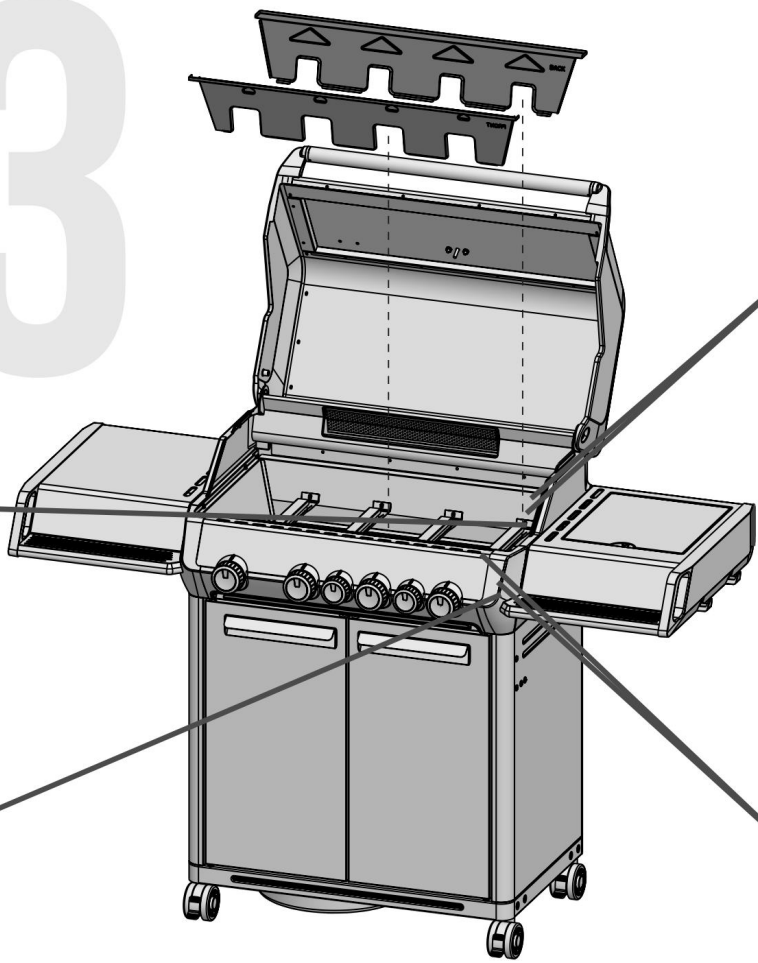
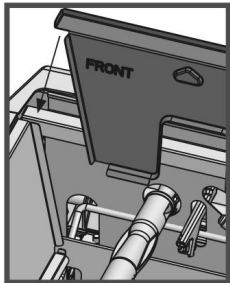
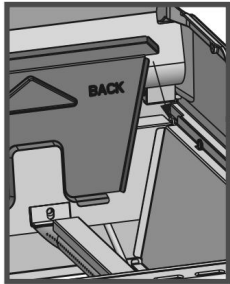

32	1x
33	1x

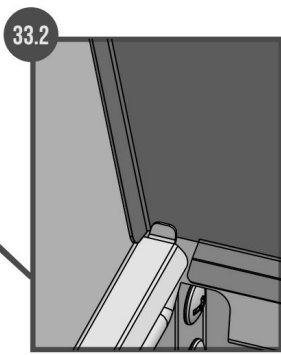
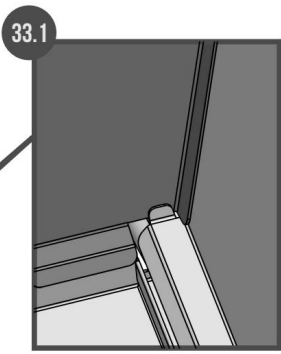

34

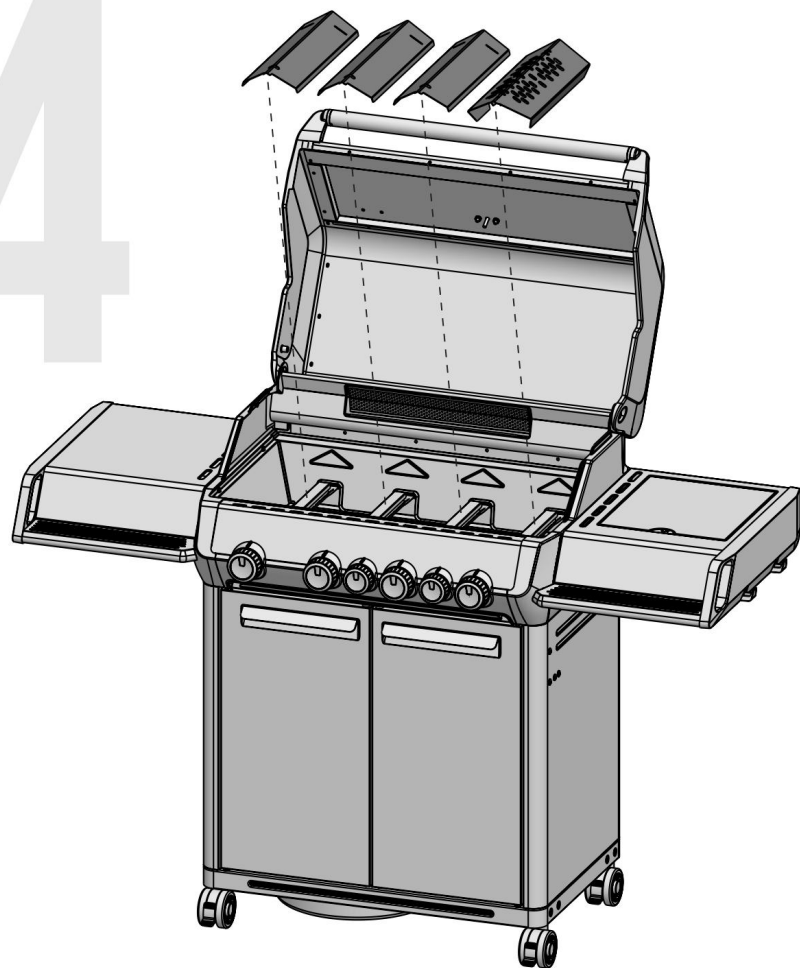

34	3x
35	1x

35

Part 37 only for item-no.
8366 and 836633

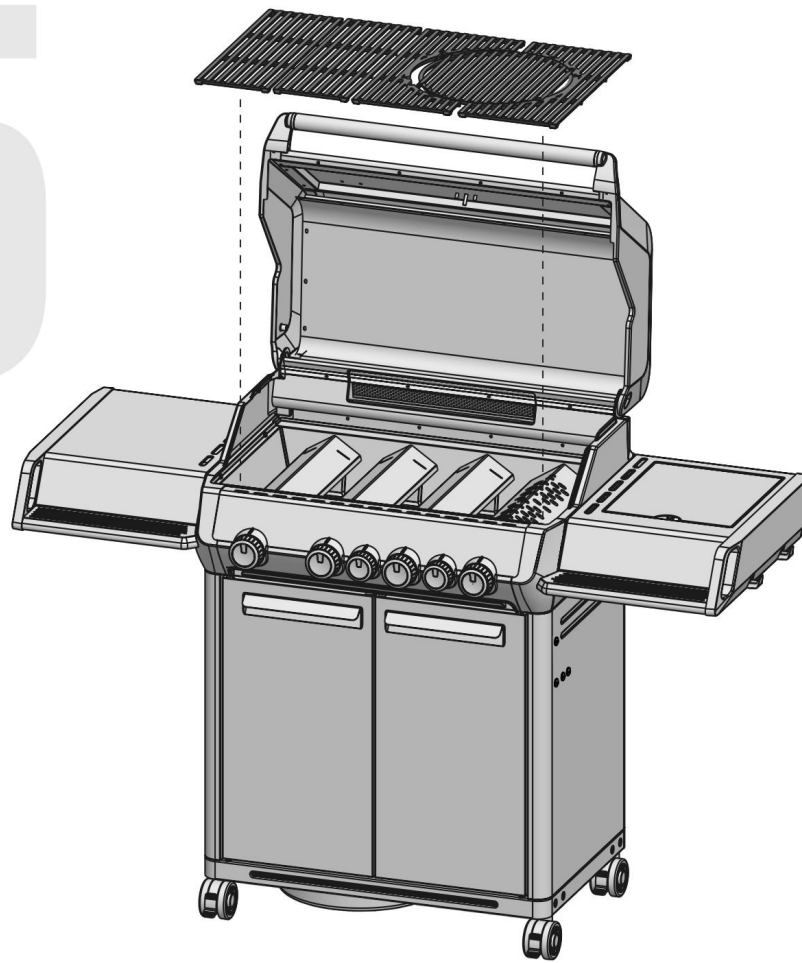

36 1x

37 1x

36

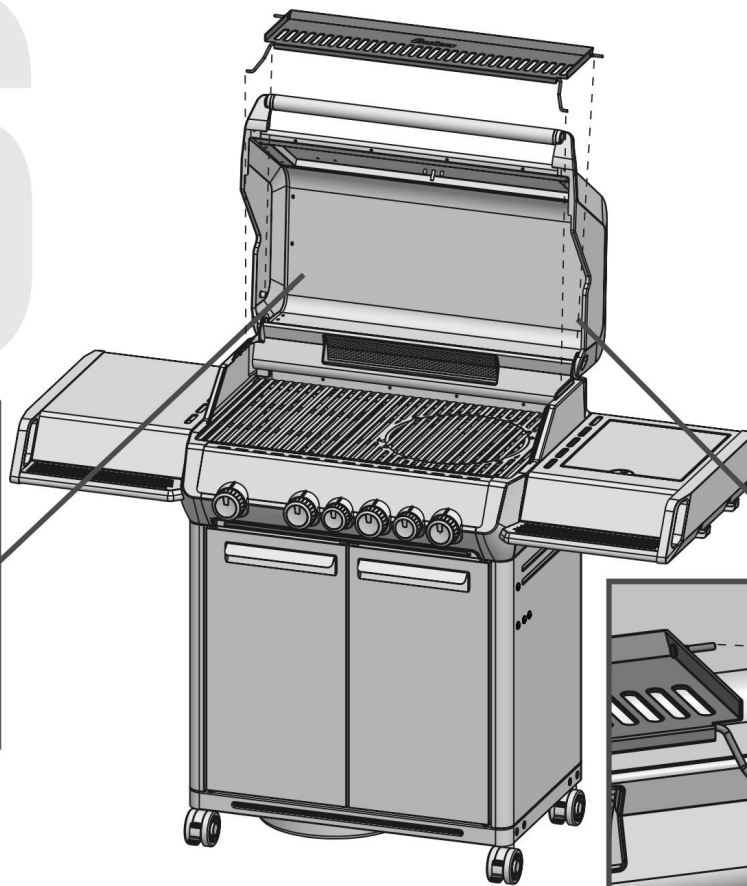
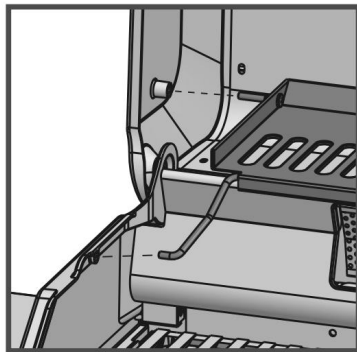

38 1x

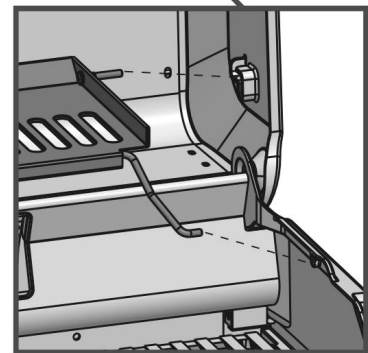







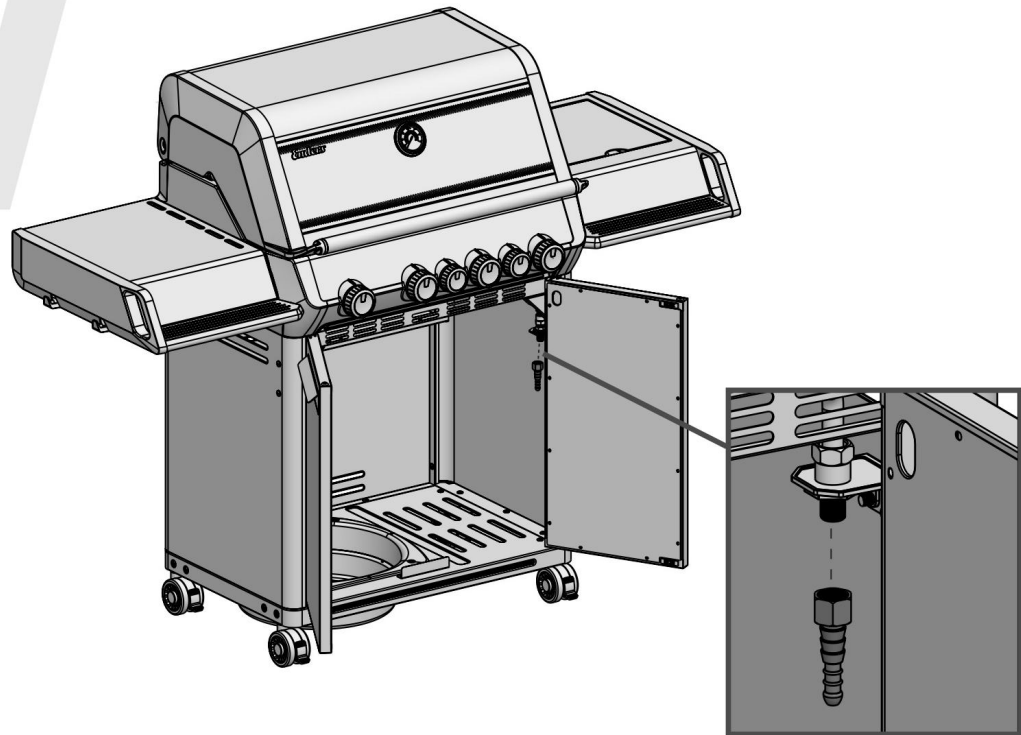



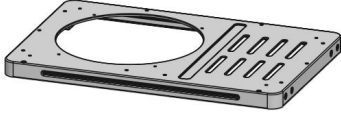

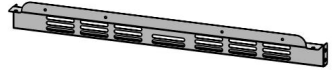
37

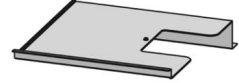
Only for item-no.
836233 and 836633

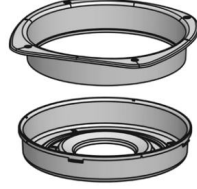
39 1x

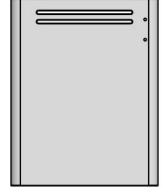

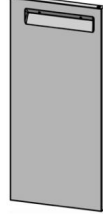
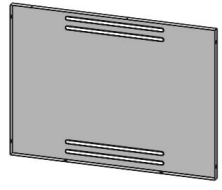
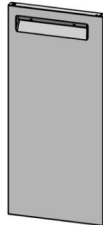
**SPARE PART LIST
FOR ITEM NO. 8362 AND 836233**

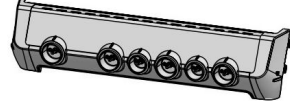
1		1x	130001320	10		1x	130001412
2		2x	130001396	11		1x	130001413
3		2x	130001397	12		1x	130001316
4		4x	130001094	13		4x	130001400
5		1x	130001298	14		1x	130001297
6		1x	130001292	15		2x	130001318
7		1x	130001300	16		1x	130001317
8		1x	130001321	17		1x	130001319
9		2x	130001416	18		1x	130001312 Only for item-no. 8362 and 836233
				18.1		1x	130001311 Only for item-no. 8362

18.2

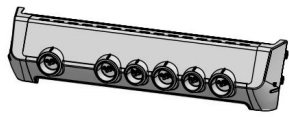

130001325

Only for item-no. 836233

1x

18.3



130001103

Only for item-no. 8362

1x

18.4



130001326

Only for item-no. 836233

1x

18.5



130001170

Only for item-no. 8362

1x

18.6



130001327

Only for item-no. 836233

1x

18.7



130001274

1x

18.8



130001310

1x

18.9



130001209

1x

18.10



130001401

1x

18.11



130001283

1x

19



130001287

3x

20



130001289

2x

21



130001288

TURBO

1x

22



130001322

1x

23

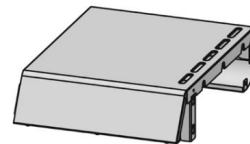

130001286

1x

24



130001323

1x

25

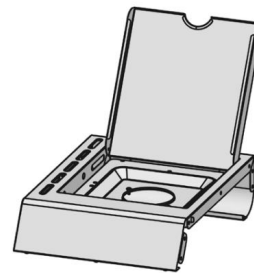

130001303

1x

26



130001304







1x

27

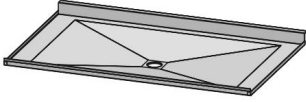
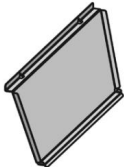
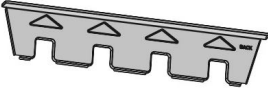
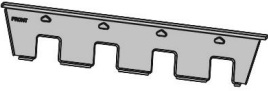
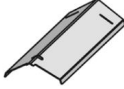

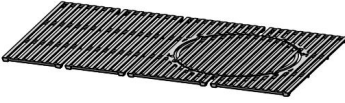









130001305













1x

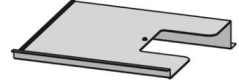

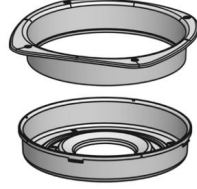

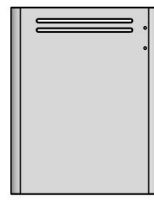

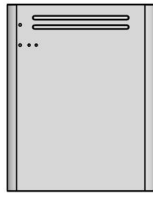
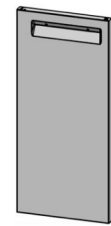
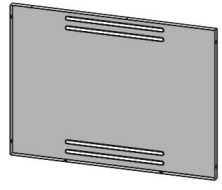

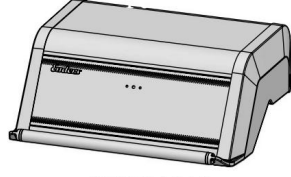
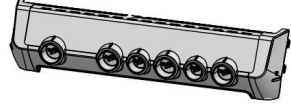

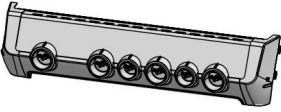
28	 130001291	1x
29	 130001315	1x
30	   130001313	1x
31	 130001278	3x
32	 130001277	1x
33	 130001309 Set of 5	1x
34	 130001314	1x
35	 130008388 Only for item-no. 836233	1x
36	 130001045 Only for item-no. 8362	1x

A/B/C/
D/E/F/
G/H/I/J
/K





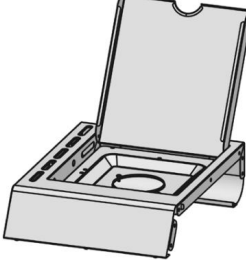

-  M6 x 10
-  M6 x 8
-  M5 x 10
-  M4 x 6
-  M4 x 10
-  M4 x 15
-  ST4.2 x 6
-  ST4.2 x 10
- 
- 
-  M6 x 15
- 130001324
- complete screw set**

**SPARE PART LIST
FOR ITEM NO. 8366 AND 836633**

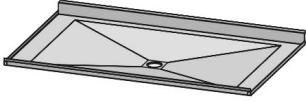
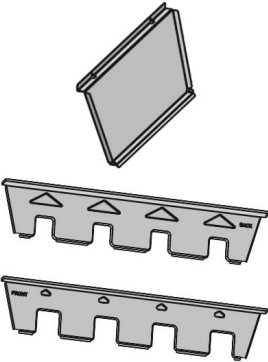
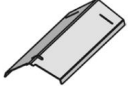

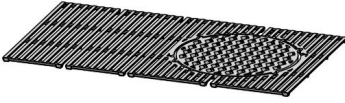







1		1x	130001351	10		1x	130001414
2		2x	130001396	11		1x	130001415
3		2x	130001397	12		1x	130001316
4		4x	130001094	13		4x	130001400
5		1x	130001298	14		1x	130001297
6		1x	130001336	15		2x	130001318
7		1x	130001340	16		1x	130001349
8		1x	130001352	17		1x	130001350
9		2x	130001416	18		1x	130001343 Only for item-no. 8366 and 836633
				18.1		1x	130001344 Only for item-no. 8366

18.2	 130001348 Only for item-no. 836633	1x
18.3	 130001103 Only for item-no. 8366	1x
18.4	 130001326 Only for item-no. 836633	1x
18.5	 130001170 Only for item-no. 8366	1x
18.6	 130001327 Only for item-no. 836633	1x
18.7	 130001274	1x
18.8	 130001310	1x
18.9	 130001209	1x
18.10	 130001401	1x
18.11	 130001283	1x

19	 130001333	3x
20	 130001335	2x
21	 130001334 TURBO	1x
22	 130001322	1x
23	 130001332	1x
24	 130001323	1x
25	 130001342	1x
26	 130001304	1x
27	 130001305	1x

28	 130001291	1x
29	 130001315	1x
30	 130001313	1x
31	 130001278	3x
32	 130001277	1x
33	 130001328 Set of 5	1x
34	 130001314	1x
35	 130008388 Only for item-no. 836633	1x
36	 130001045 Only for item-no. 8366	1x

A/B/C/
D/E/F/
G/H/I/J
/K

-  M6 x 10
-  M6 x 8
-  M5 x 10
-  M4 x 6
-  M4 x 10
-  M4 x 15
-  ST4.2 x 6
-  ST4.2 x 10
- 
- 
-  M6 x 15
- 130001353
- complete screw set**

Enders[®]

Enders Colsman AG

Brauck 1

D-58791 Werdohl, Germany

+ 49 (0) 2392 9782 30

www.enders-germany.com

251017